

Pressure Relief Valve

For mounting on hydraulic pumps and motors
 Series AS(G)DF and ASDH



- short response times
- trouble-free operation
- with improved pressure-adjustment resolution
- high levels of functionality and stability
- low pressure increase and minimal pressure peaks
- cost-saving, thanks to direct mounting on hydraulic pumps

1 Product description

1.1 General

Series AS.. pressure relief valves regulate the operating pressure and flow rate in a hydraulic system and protect it. Regardless of the maximum operating pressure that has been set, the valve can be switched to unloaded bypass via an external pilot port.

The pressure-relief valves are intended for direct mounting on hydraulic pumps with SAE flange ports. The main components of the valves are a body and a pressure-relief cart-

ridge. The pressure-relief valve is a cartridge unit with a seated pilot stage and a spool-type main stage.

When the pilot stage is active (PR function), the pilot oil is internally drained to port T, which should preferably be routed to tank with the least possible back-pressure because any pressure at port T is additive to the valve setting.

The required pressure can be set with an adjusting screw, which is secured by a lock nut.

1.2 Other applicable documentation

Model code	Fitted in nominal sizes	Data sheet
Pressure-relief cartridge, size10 series DVPA-2...	SAE 1/2", SAE 3/4" and SAE 1"	400-P-280111

2 Technical data

General characteristics	Description, value, unit
Type	bolt-on valve for SAE flanged ports, seated pilot stage, spool-type main stage, with remote-control port Z
Mounting method (standard)	interface to SAE J518 code 61 and ISO 6162-1 (mounting bolts are not included in the delivery)
Installation attitude	unrestricted
Flow rate Q_{max}	140 l/min (see performance graph)
Operating pressure	max. 350 bar
Opening pressure for the check valve (type "R" only)	0.3 bar
Adjustment range for the pressure-relief function (stepless, manually adjustable)	1 = 20 - 65 bar 2 = 20 - 210 bar 3 = 20 - 315 bar
Maximum permissible pressure at port T	20 bar (the pressure at port T is additive to the setting at the pressure-relief adjustment)
Minimum fluid cleanliness	NAS 1638, class 9 or ISO 4406, code 20/18/15
Hydraulic fluid	Mineral oil to DIN 51524 and 51525 (other fluids by consultation)

General characteristics	Description, value, unit
Viscosity range	10 - 300 mm ² /s
Fluid temperature range	-20 ... +60°C
Body material	GGG40

3 Symbol

Standard

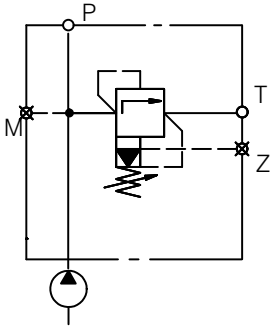

Option with integral check valve
Model AGDF only

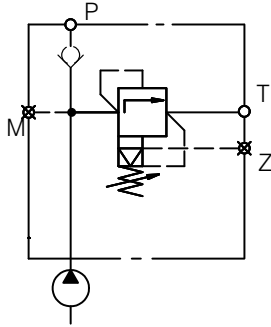

Option with external check valve
Model ASDF only

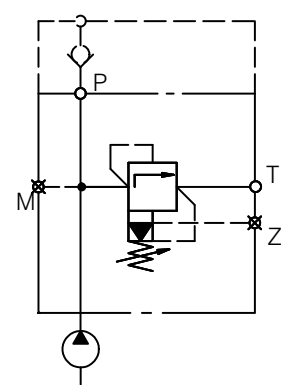

4 Performance graphs (Measured at 33 mm²/s [cSt])

4.1 Δp - Q pressure range 20 - 65 bar

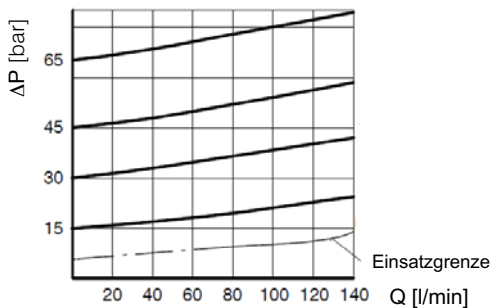

4.3 Δp - Q pressure range 20 - 315 bar

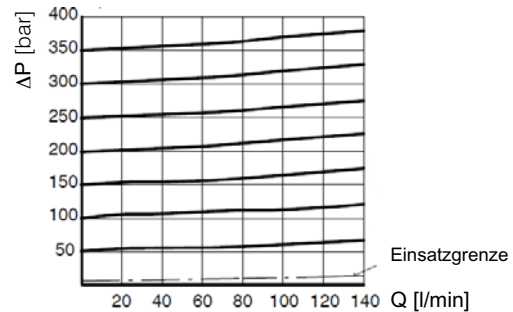

4.2 Δp - Q pressure range 20 - 210 bar

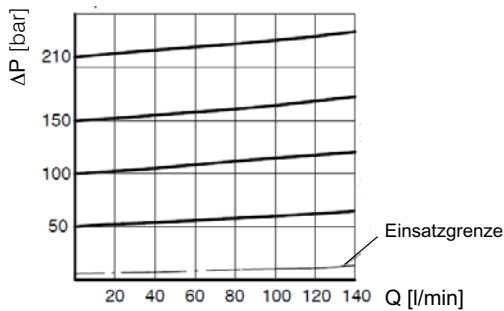

4.4 Leakage from A to B

Measured at p_B = 0 bar, pilot stage closed

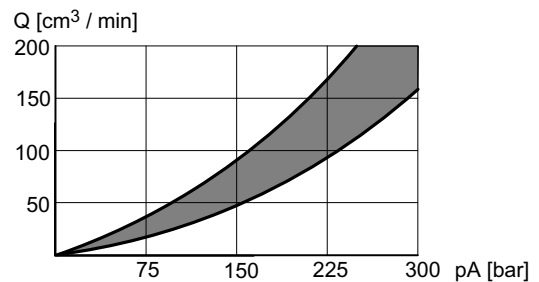

5 Dimensions

5.1 With threaded ports (series AGDF)

5.1.1 Size 1/2"

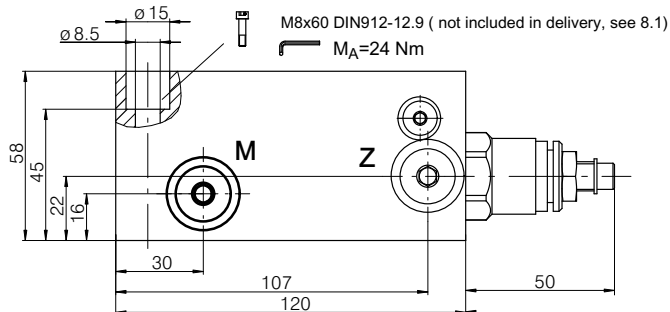

Option (...R*...)

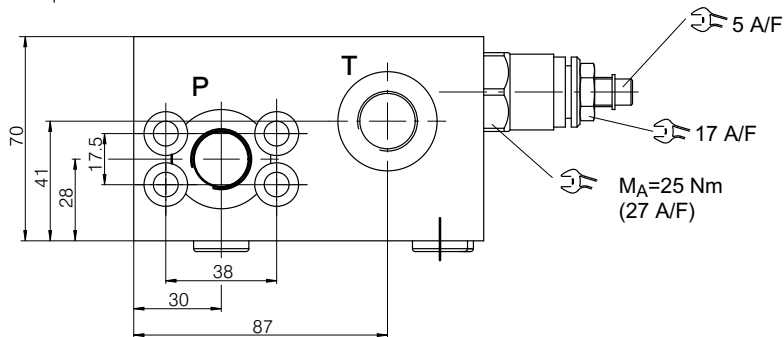

P, T = G 1/2" M, Z = G 1/4"

5.1.2 Size 3/4" and 1"

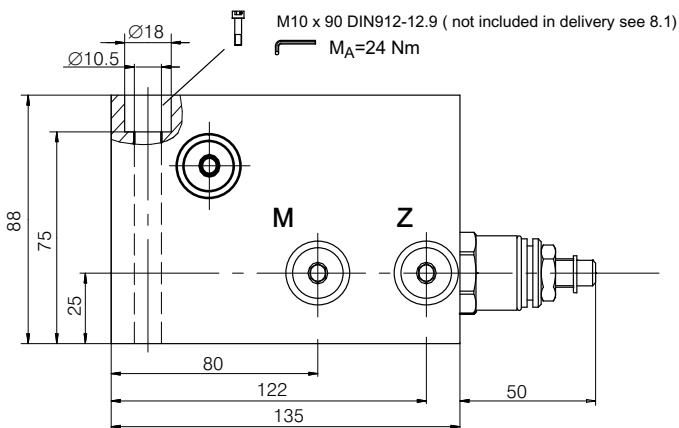

Option (...R*...)

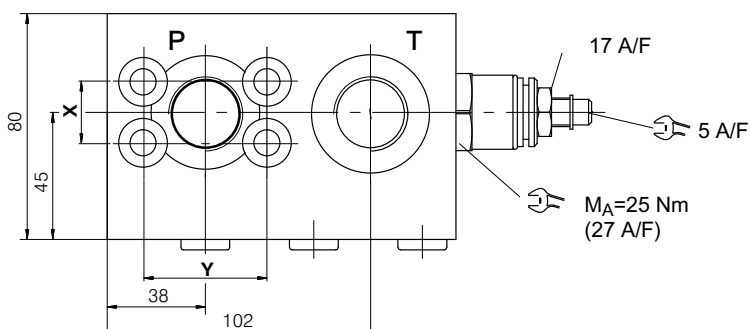

Dimension

P + T	M + Z	X	Y
3/4"	1/4"	22,2	47,6
1"	1/4"	26,2	52,4

5.2 With ports for SAE pipe flanges (series ASDF/ASDH)

5.2.1 Size SAE 1/2"

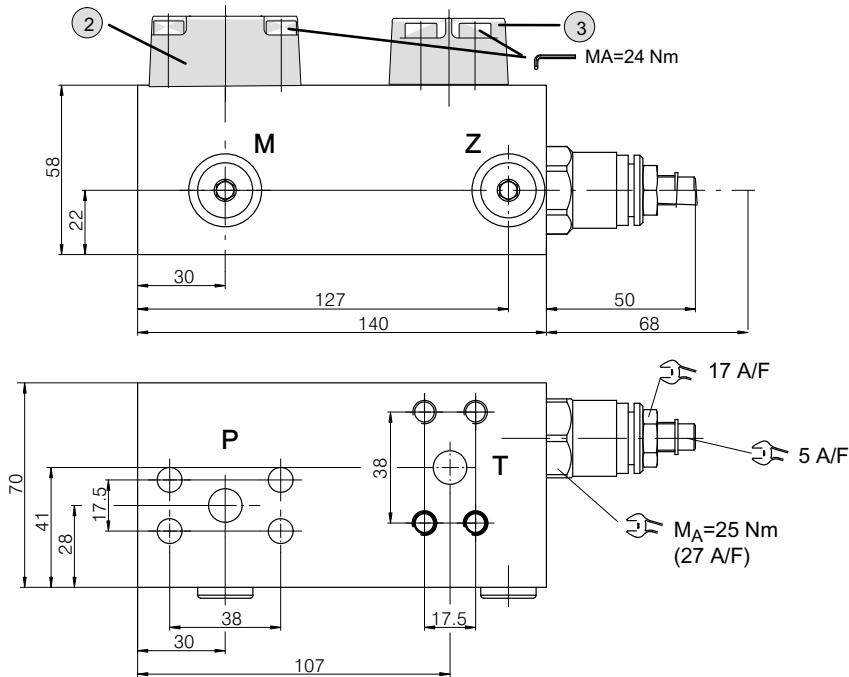

5.2.2 Size SAE 3/4" and 1"

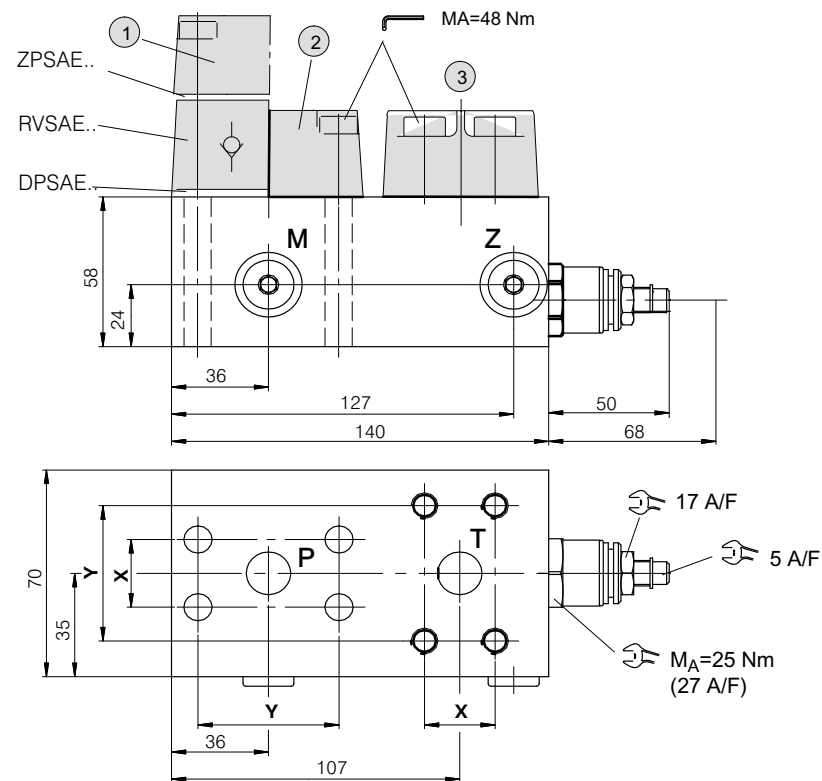

M, Z = G 1/4"

	X	Y
SAE 3/4"	22,2	47,6
SAE 1"	26,2	52,4

1	Version with check valve and SAE pipe flang at port P (see 8.3)
2	Version with SAE pipe flang at port P (see 8.2.2)

3	Version with SAE pipe flang at port T (see 8.2.1)
---	---

6 Installation information

- Mounting bolts for fitting the valve are not included in the delivery
- Sealing ring for the flange side (pump) is included in the delivery
- Required surface finish of flange pad for mounting the valve

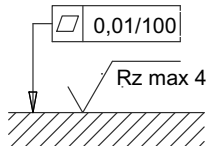

IMPORTANT!

When fitting the valves, use the specified tightening torque for the mounting bolts. The pressure-relief function is factory-set. The setting must be checked.



ATTENTION!

Only qualified personnel with mechanical skills may carry out any maintenance work. Generally, the only work that should ever be undertaken is to check, and possibly replace, the seals. When changing seals, oil or grease the new seals thoroughly before fitting them.

7 Ordering code

		A	G	D	F	2	-	1	/	2	-	R	*	-	0	P= 1)
SAE bolt-on valve																
With ports for SAE J518 code 61 (ISO 6162-1) flanges		= S														
With threaded ports		= G														
Pressure-relief function																
fixed setting		= DF														
manual adjustment (for SAE series AS only)		= DH														
Adjustment range for the pressure-relief function:																
20... 65 bar		= 1														
20...210 bar		= 2														
20...315 bar		= 3														
Nominal size of SAE flange or threaded ports P and T																
G or S (SAE) 1/2"		= 1/2														
G or S (SAE) 3/4"		= 3/4														
G or S (SAE) 1"		= 1/1														
Check valve integrated in threaded-port P (only in models with threaded ports)		= R														
Without check valve		= *														
Remote-control port Z		= Z														
Without port Z		= *														
Design stage (to be inserted by the factory)																

1) Specify the required pressure setting (P_{max}) in plain text.



IMPORTANT!

- Mounting bolts for fitting the valve are not included in the delivery
- Sealing ring for the flange side (pump) is included in the delivery
- SAE pipe flanges and check valves for SAE flange ports must be ordered separately.

8 Accessories

8.1 Cap screws

Description	Ordering code for 1 piece	Data sheet
Cap screws M8 x 60 - DIN 912-12.9	100234776	100-D-404947
Cap screws M10 x 90 - DIN 912-12.9	100240420	100-D-404947

8.2 SAE pipe flanges

- max. working pressure 420 bar

- interface to SAE J518 code 61 / ISO 6162-1

Mounting bolts and O-ring are included with the delivery. Threaded pipe flanges are spot-faced for DIN 2353 pipe fittings. Material: ST37

8.2.1 SAE pipe flanges for port „T“

Ordering code	Thread	Ordering number	O. Ring, 90 Shore A	Retaining screws DIN912-12.9 / Torque Nm	
RF01-R08	G 1/2"	100037000	20,24x2,62	M8x30	24
RF02-R10	G 3/4"	100037010	26,65x2,62	M10x30	48
RF03-R11	G 1"	100037020	32,99x2,62	M10x35	48



8.2.2 SAE pipe flanges for port „P“

Ordering code	Thread	Ordering number	O. Ring, 90 Shore A	Retaining screws DIN912-12.9 / Torque Nm	
RF01-R08 1/2" ASD	G 1/2"	100036196	20,24x2,62	M8x30	24
RF02-R10 3/4" ASD	G 3/4"	100036198	26,65x2,62	M10x30	48
RF03-R11 1" ASD	G 1"	100036201	32,99x2,62	M10x35	48



8.3 SAE pipe flanges and RVSAE check valves for port „P“

Ordering code	Thread	Ordering number	O. Ring, 90 Shore A	Retaining screws DIN912-12.9 / Torque Nm	
RF02-R10 3/4" + RVSAE ASD	G 3/4"	100036203	20,24x2,62	M10x125	48
RF03-R11 1" + RVSAE ASD	G 1"	100036205	26,65x2,62	M10x135	48



9 Possible ordering variants

Connection type	Pump	Bolt-on valve	Functions				
			With integral check valve	With check valve for SAE port ¹⁾	Without check valve	With remote-control port	Without remote-control port
Thread	QX2.	AGDF_-1/2-	x		x	x	x
	QX3.	AGDF_-3/4-	x		x	x	x
	QX4.	AGDF_-1/1-	x		x	x	x
SAE J518	QX2./117	ASDF_-1/2-			x	x	x
	QX3./117	ASDF_-3/4-		x	x	x	x
	QX4.	ASDF_-1/1-		x	x	x	x

10 Installation example

10.1 ASDF with RVSAE on series QXEH42 internal gear pump

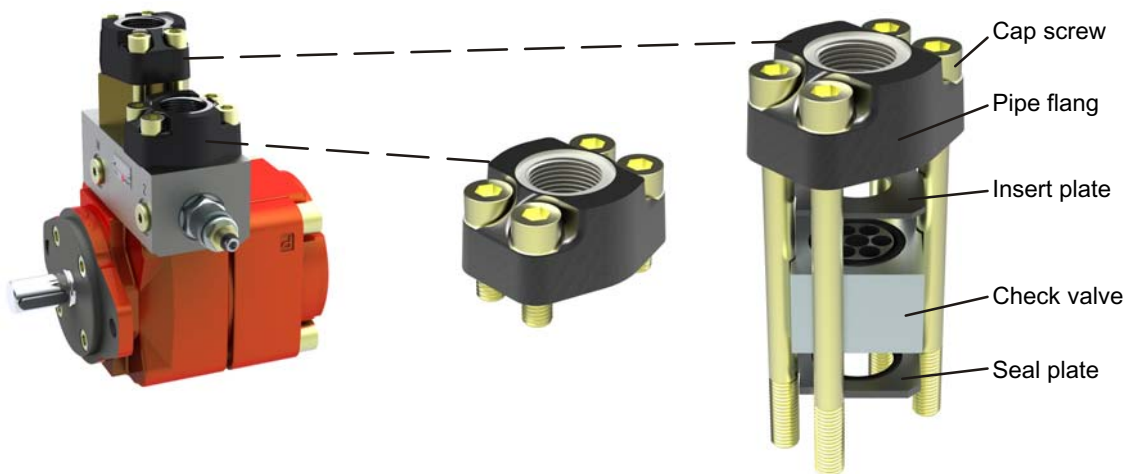

10.2 Ordering information for example 10.1

- Pressure relief valve = ASDF2-3/4-**
- SAE pipe flange for port „T“ = RF02-R10 3/4“ (100037010)
- SAE pipe flange and check valve for port „P“ = RF02-R10 3/4“ + RVSAE ASD (100036203)

info.kl@bucherhydraulics.com

www.bucherhydraulics.com

© 2015 by Bucher Hydraulics GmbH, D-79771 Klettgau

All rights reserved.

Data is provided for the purpose of product description only, and must not be construed as warranted characteristics in the legal sense. The information does not relieve users from the duty of conducting their own evaluations and tests. Because the products are subject to continual improvement, we reserve the right to amend the product specifications contained in this catalogue.

Classification: 430.310.