

# Proportional Pressure-Relief Cartridge Valve, Size 2...4

$Q_{\max} = 24 \text{ l/min}$ ,  $p_{\max} = 350 \text{ bar}$   
Direct acting, electrically operated  
Series DBDRB-1L...



- Compact construction for cavity type AL – 3/4-16 UNF
- Operated by a proportional solenoid
- In a power failure, the pressure setting drops to the minimum value
- 6 pressure ranges available
- All exposed parts with zinc-nickel plating
- High pressure wet-armature solenoids
- The slip-on coil can be rotated, and it can be replaced without opening the hydraulic envelope
- With integral manual pressure setting
- Can be fitted in a line-mounting body

## 1 Description

Series DBDRB-1L... proportional pressure-relief valves are direct acting screw-in cartridges of sliding-spool design with a 3/4-16 UNF mounting thread. With these pressure-relief cartridges, the relief pressure is dependent on the electrical control signal and can be continuously varied. When the solenoid is de-energised (initial position), connection 2 → 1 is open and the minimum pressure (free flow) depends on the flow rate. Any pressure at port 1 is additive to the valve setting at port 2, therefore port 1 should preferably be connected directly to tank. In control mode, the relief pressure is proportional to the change in the required value (amplifier output current). In order to obtain precise pressure settings over the whole of the required pressure range (optimum resolution), the pressure relief cartridges are available in six

spring ranges. If a proportional solenoid is faulty, for example, the integral manual pressure setting enables the required pressure to be set mechanically. Proportional pressure-relief cartridges are predominantly used in mobile and industrial applications to allow a pressure in hydraulic installations to be limited electro-proportionally. All external parts of the cartridge are zinc-nickel plated to DIN 50 979 and are thus suitable for use in the harshest operating environments. The slip-on coils can be replaced without opening the hydraulic envelope and can be positioned at any angle through 360°. If you intend to manufacture your own cavities or are designing a line-mounting installation, please refer to the section "Related data sheets".

## 2 Symbol

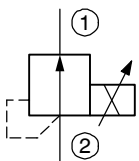

## 3 Technical data

General characteristics	Description, value, unit
Designation	proportional pressure-relief cartridge
Design	direct acting, electrically operated
Mounting method	screw-in cartridge 3/4-16 UNF
Tightening torque	40 Nm ± 10 %
Size	nominal size 2...4, cavity type AL
Weight	0.50 kg

General characteristics	Description, value, unit
Mounting attitude	unrestricted (preferably vertical, coil down)
Ambient temperature range	-25 °C ... +50 °C

Hydraulic characteristics	Description, value, unit
Maximum operating pressure - main port 2 - port 1	350 bar 250 bar <sup>1)</sup>
Maximum flow rate	24 l/min
Nominal pressure ranges	...25 bar, ...63 bar, ...100 bar, ...160 bar, ...230 bar, ...350 bar
Leakage flow rate 2 → 1	... 0.10 l/min = pressure range 25 bar / 63 bar ... 0.20 l/min = pressure range 100 bar ... 0.25 l/min = pressure range 160 bar ... 0.30 l/min = pressure range 230 bar ... 0.40 l/min = pressure range 350 bar
Flow direction	2 → 1 see symbols
Hydraulic fluid	HL and HLP mineral oil to DIN 51 524; for other fluids, please contact BUCHER
Hydraulic fluid temperature range	-25 °C ... +70 °C
Viscosity range	15...380 mm <sup>2</sup> /s (cSt), recommended 20...130 mm <sup>2</sup> /s (cSt)
Minimum fluid cleanliness Cleanliness class to ISO 4406 : 1999	class 18/16/13



### ATTENTION!

<sup>1)</sup> To prevent any pressure surges, port 1 must be routed to tank with the least possible back-pressure. Any tank pressure acting at port 1 is additive to the pressure setting at the main port 2.

Electrical characteristics	Description, value, unit
Supply voltage	12 V DC, 24 V DC
Control current	12 V = 0...1600 mA, 24 V = 0...800 mA
Power consumption at max. control current	max. 19.5 W
Coil resistance R - cold value at 20 °C - max. warm value	12 V = 4.8 Ω / 24 V = 17.7 Ω 12 V = 7.5 Ω / 24 V = 30 Ω
Recommended PWM frequency (dither)	200 Hz
Hysteresis with PWM	2...4 % I <sub>N</sub>
Reversal error with PWM	2...4 % I <sub>N</sub>
Sensitivity with PWM	< 1 % I <sub>N</sub>
Reproducibility with PWM	< 2 % p <sub>N</sub>
Switching time	20 ... 60 ms (Solenoid ON) 6 ... 20 ms (Solenoid OFF) <small>These times are strongly influenced by fluid pressure, flow rate and viscosity, as well as by the dwell time under pressure.</small>
Relative duty cycle	100 %
Protection class to ISO 20 653 / EN 60 529	IP 65
Electrical connection	3-pin square plug to ISO 4400 / DIN 43 650 (standard) for other connectors, see "Ordering code"

## 4 Performance graphs measured with oil viscosity 33 mm<sup>2</sup>/s (cSt)

$p = f(I)$  Pressure adjustment characteristic ( $Q = 1$  l/min)

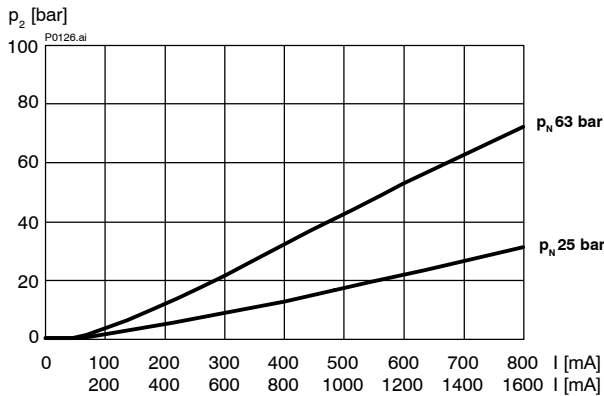

$p = f(I)$  Pressure adjustment characteristic ( $Q = 1$  l/min)

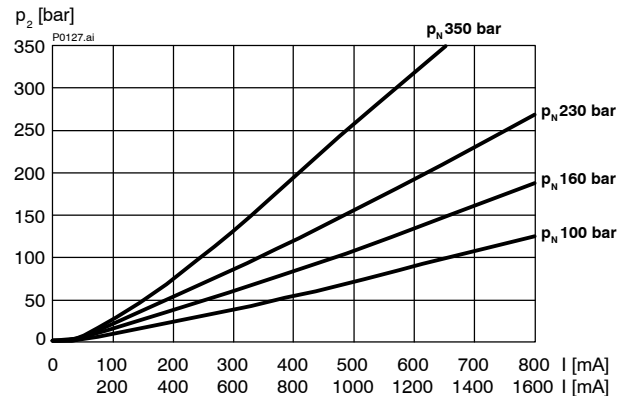

$p = f(Q)$  Pressure - Flow rate characteristic  $p_N = 25$  bar

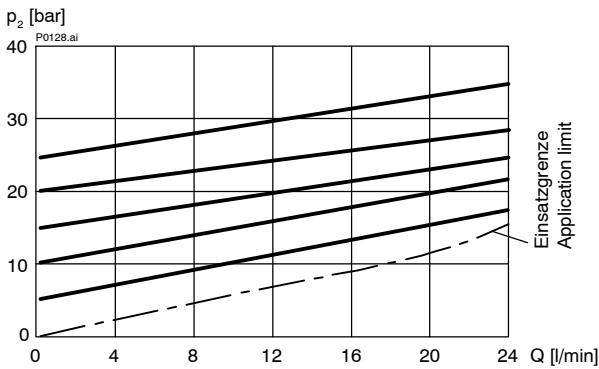

$p = f(Q)$  Pressure - Flow rate characteristic  $p_N = 63$  bar

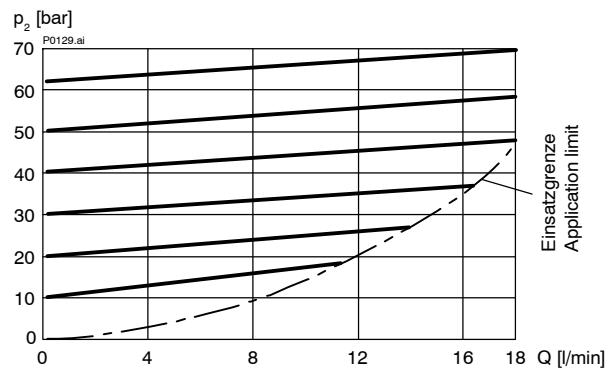

$p = f(Q)$  Pressure - Flow rate characteristic  $p_N = 100$  bar

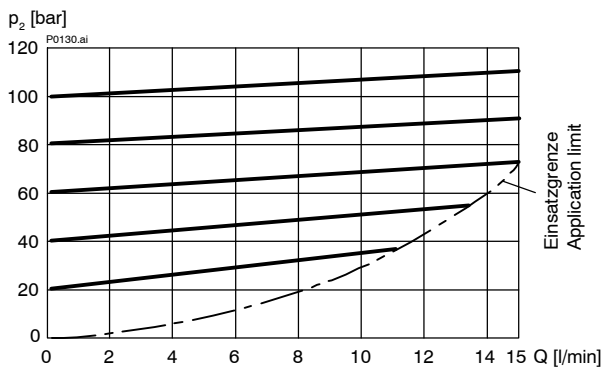

$p = f(Q)$  Pressure - Flow rate characteristic  $p_N = 160$  bar

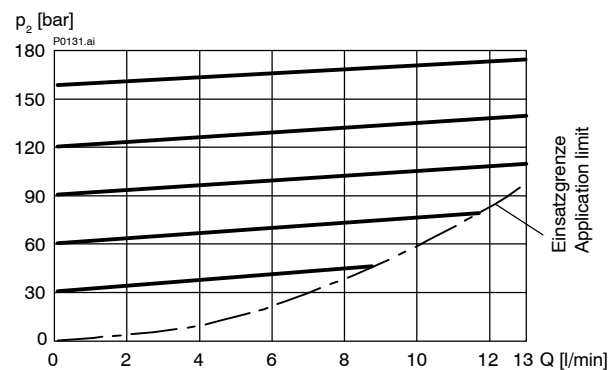

$p = f(Q)$  Pressure - Flow rate characteristic  $p_N = 230$  bar

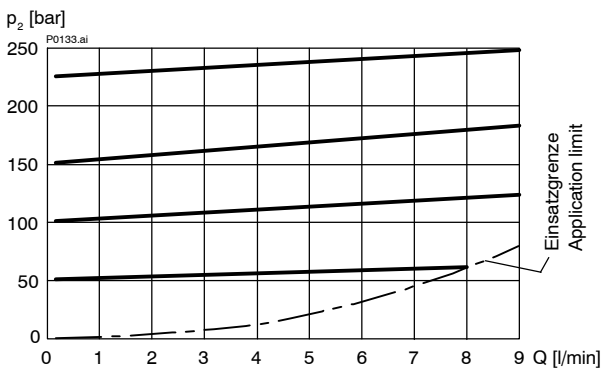

$p = f(Q)$  Pressure - Flow rate characteristic  $p_N = 350$  bar

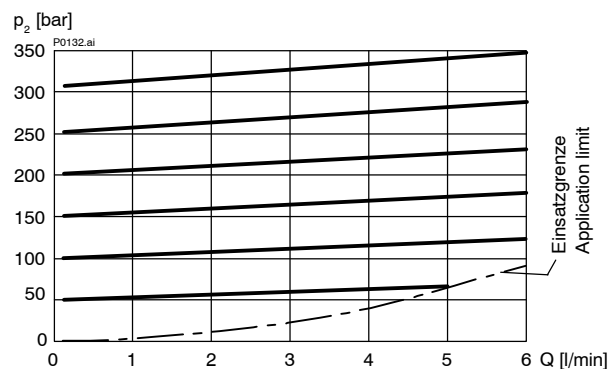

## 5 Dimensions & sectional view

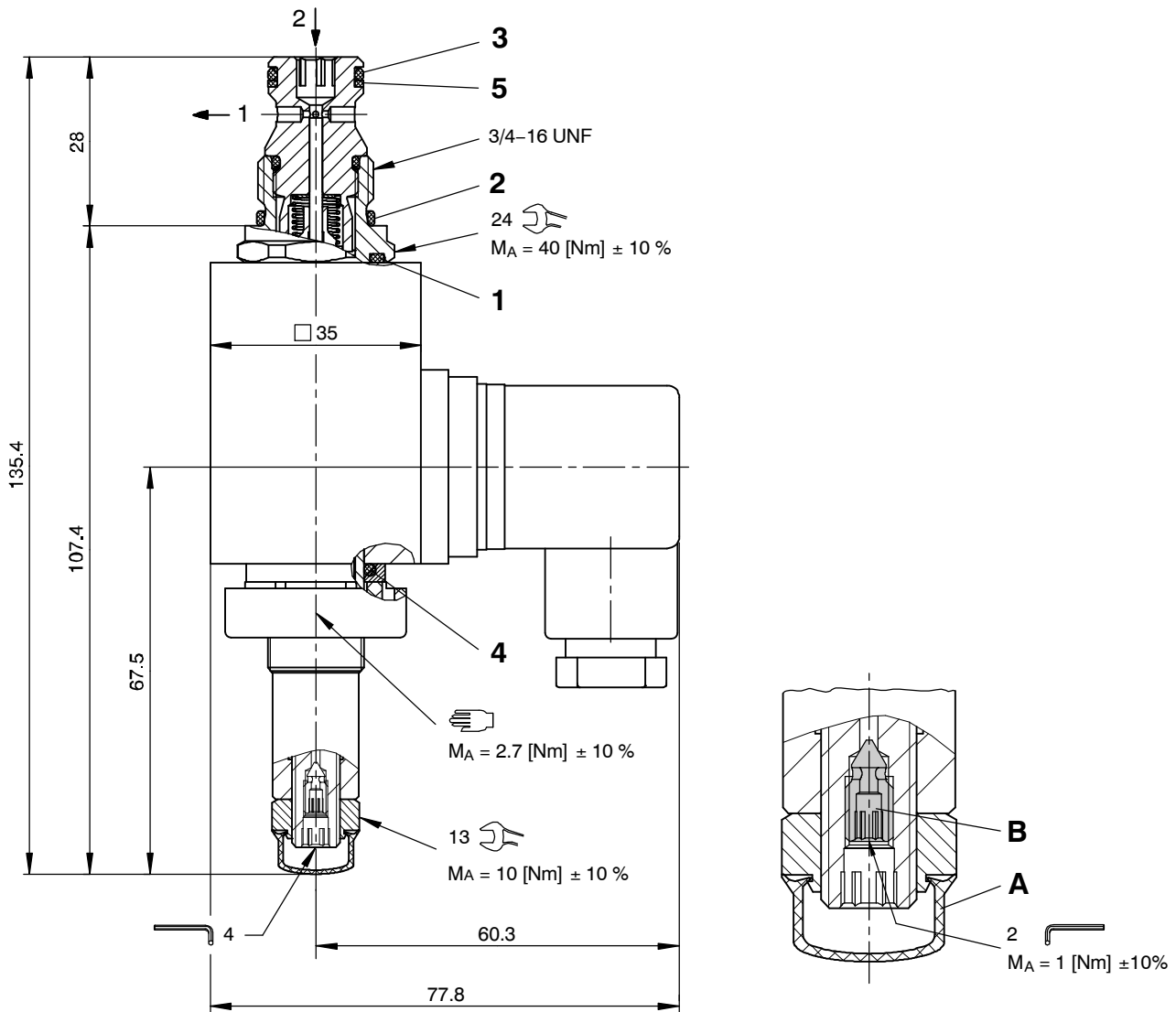

Seal kit NBR no. DS-284-N <sup>1)</sup>

Item	Qty.	Description
1	1	O-ring $\varnothing$ 18.00 x 2.00 FKM
2	1	O-ring no. 017 $\varnothing$ 17.17 x 1.78 N90
3	1	O-ring no. 014 $\varnothing$ 12.42 x 1.78 N90
4	1	O-ring $\varnothing$ 16.00 x 2.00 FKM
5	1	Backup ring $\varnothing$ 10.70 x 1.45 x 1.00 FI0751



### IMPORTANT!

<sup>1)</sup> Seal kit with FKM (Viton) seals no. DS-284-V

### Integral air-bleeding

If necessary, air can be purged from these proportional pressure-relief cartridges by using the integral air-bleed screw (Item B). The procedure is as follows:

- K Protective cap
- L Air-bleed screw

### Steps:

7. Remove the protective cap.
8. Slacken the air-bleed screw approx. 2 turns.
9. Switch the pressure-relief cartridge ON/OFF several times until no more air bubbles escape.
10. Tighten the air-bleed screw ( $M_a = 1 \text{ Nm} \pm 10\%$ ).
11. Fit the protective cap.

## 6 Installation information



### IMPORTANT!

To achieve the proportional pressure-relief cartridge's maximum performance rating, fit the solenoid coil as shown (with the plug pins at the bottom). When fitting the cartridges, note the mounting attitude (preferably vertical, with coil down → automatic air bleed) and use the specified tightening torque. No adjustments are necessary, since the cartridges are set in the factory.



### ATTENTION!

To prevent any pressure surges, port 1 must be routed to tank with the least possible back-pressure. Any tank pressure acting at port 1 is additive to the pressure setting at the main port 2.



### ATTENTION!

Only qualified personnel with mechanical skills may carry out any maintenance work. Generally, the only work that should ever be undertaken is to check, and possibly replace, the seals. When changing seals, oil or grease the new seals thoroughly before fitting them.

## 7 Manual pressure setting

These proportional pressure-relief cartridges are equipped as standard with an integral manual pressure setting. If a proportional solenoid is faulty, for example, this manual pressure setting enables the required pressure to be set mechanically. This manual pressure setting is not designed for adjusting the pressure in a dynamic control mode.

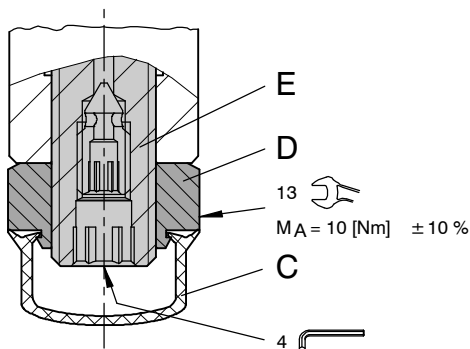

M Protective cap

N Lock nut (13 A/F)

O Adjusting spindle for pressure setting

### Setting the pressure manually

Steps:

1. Remove the protective cap.
2. Slacken the lock nut (13 A/F).
3. Screw in (turn to right) the adjusting spindle (4 A/F) until the required pressure is set.
4. Tighten the lock nut (13 A/F).
5. Fit the protective cap.



### ATTENTION!

To reset the proportional pressure-relief cartridges to their initial position (the factory setting), a constant flow rate (e.g. 1 l/min) and a pressure gauge that measures the pressure in the main port 2 are needed. The procedure is as follows:

### Restoring the factory settings

Steps:

1. Solenoid de-energised.
2. Remove the protective cap.
3. Slacken the lock nut (13 A/F).
4. Unscrew the adjusting spindle (4 A/F) to its end-stop, then screw it in until the pressure on the gauge just starts to rise.
5. Unscrew the spindle again by:
 

350 bar	=	1/4 of a turn
230, 160, 100 bar	=	1/2 of a turn
63, 25 bar	=	3/4 of a turn
6. Tighten the lock nut (13 A/F).
7. Fit the protective cap.

### 8 Ordering code

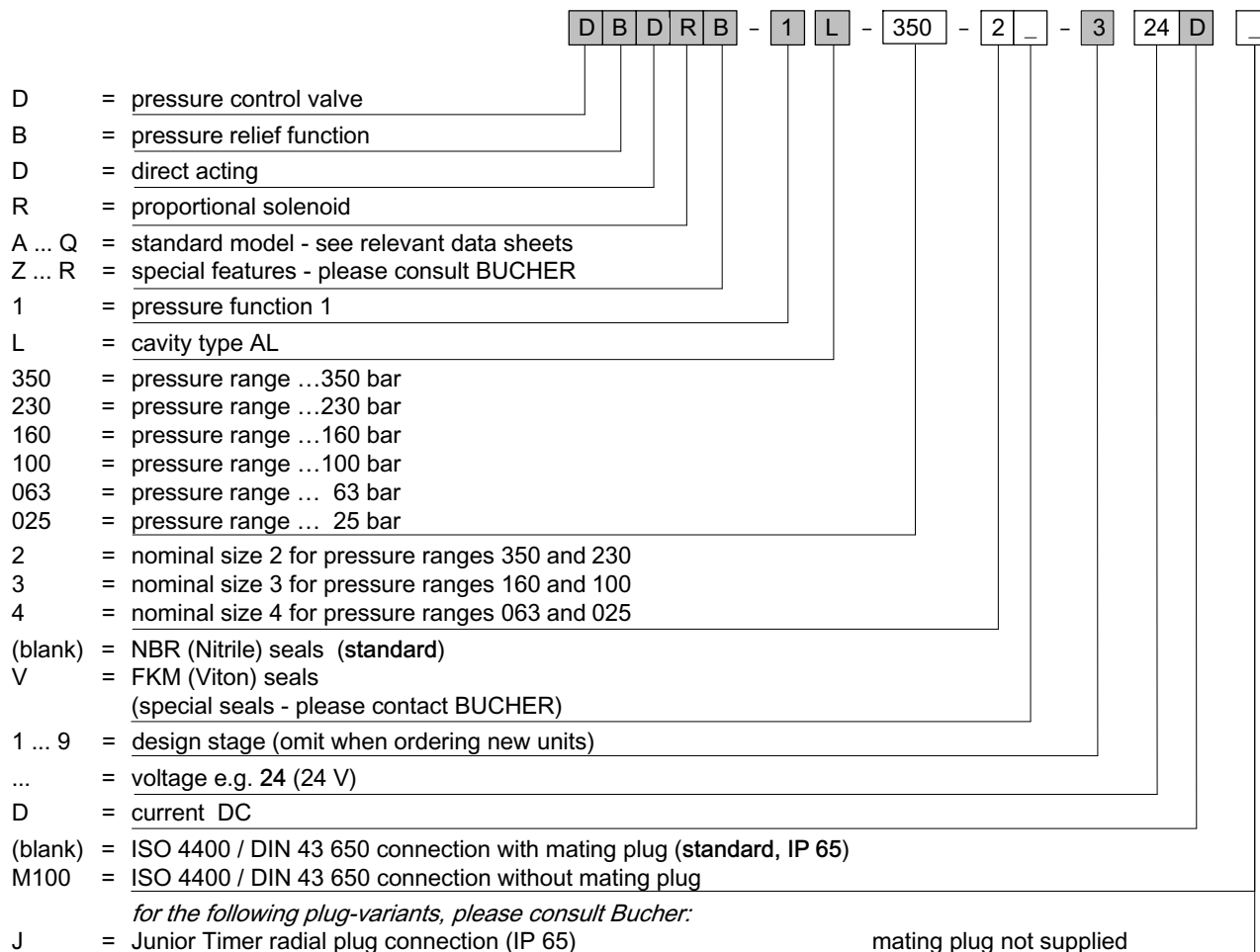

### 9 Related data sheets

Reference	(Old no.)	Description
400-P-040011	(i-32)	The form-tool hire programme
400-P-060171		Cavity type AL
400-P-510101		Amplifier unit for proportional valves (1-channel) PBS - 3A
400-P-511101	(P-3)	Amplifier card, 1-channel for valves with one solenoid, type SAN-535...
400-P-720101		Line-mounting body, type GALA (G 3/4")

info.ch@bucherhydraulics.com

www.bucherhydraulics.com

© 2016 by Bucher Hydraulics AG Frutigen, CH-3714 Frutigen

All rights reserved.

Data is provided for the purpose of product description only, and must not be construed as warranted characteristics in the legal sense. The information does not relieve users from the duty of conducting their own evaluations and tests. Because the products are subject to continual improvement, we reserve the right to amend the product specifications contained in this catalogue.

Classification: 430.305.300.305.305.310