

Pressure-Relief Cartridge Valve, Size 10

$Q_{\max} = 100 \text{ l/min}$, $p_{\max} = 350 \text{ bar}$

Poppet pilot stage, spool-type main stage with integral bypass check valve,
 Series DVPA-RV-1...



- Pilot oil drained internally to port B
- Interchangeable with DVP-RV-1-10 ...
- Very stable in operation
- Improved pressure-setting resolution
- Very tolerant of over-tightening in cavity
- BUCHER cavity type DC

1. Description

Series DVPA-RV-1-10... cartridges are 2-stage pressure relief valves with a positive seat pilot stage and spool-type main stage. When the pilot stage is active (main stage relieving), pilot oil is internally drained to port B. Any pressure in port B is additive to the spring pressure setting, therefore port B should preferably be connected to tank. Reverse flow (B to A) is made possible by the integral check valve. Thoroughly oil or grease external seals before inserting the

cartridge in a DC cavity. The cartridge can be tightened with a 27 A/F OE spanner (note the recommended tightening torque). Form tools are available for sale or hire, should customers wish to machine cavities in their own control blocks. The BUCHER line- and manifold-mounting body type DC-12 can be used where the application requires a line mounting valve. The cartridge is also available without the integral reverse flow check valve: Type DVPA-1-10 ...

2. Symbols

DVPA-RV-1-10 ...

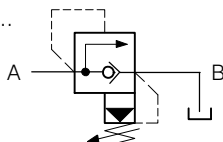

3. Characteristics

Type		pressure relief cartridge valve
Design		poppet pilot stage, spool main stage with integral spool type bypass check valve
Mounting method		screw-in cartridge (M24 x 1,5)
Size		10 mm nominal size, BUCHER cavity type DC
Mass	kg	0,23
Mounting attitude		unrestricted
Flow direction		A ⇒ B, see symbol
Operating pressure	bar	... 350 max. in A and B
Adjustment ranges, see performance curves	bar	pressure range N = 10 ... 350 pressure range M = 10 ... 210 pressure range L = 10 ... 65
Cracking pressure B ⇒ A	bar	approx. 6
Flow rate Q max.	l/min	1 ... 100 max. see performance characteristics
Fluids		Hydraulic oils HL and HLP to DIN 51 524 other fluids - contact BUCHER
Fluid temperature range	°C	-25 ... +80
Viscosity range	cSt	10 ... 650 mm ² /s, recommended 15 ... 250 mm ² /s
Minimum fluid cleanliness		20/18/15 to ISO 4406 : 1999

Reference: 400-P-280131-EN-01

4. Performance characteristics

Oil viscosity 33 cSt

Δp -Q characteristic
DVPA-RV-1-10-...N

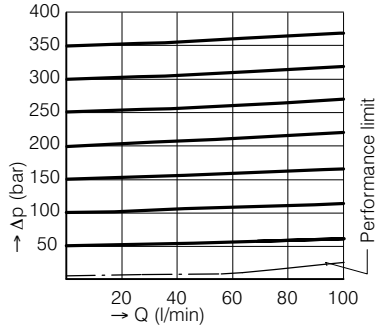

Δp -Q characteristic
DVPA-RV-1-10-...M

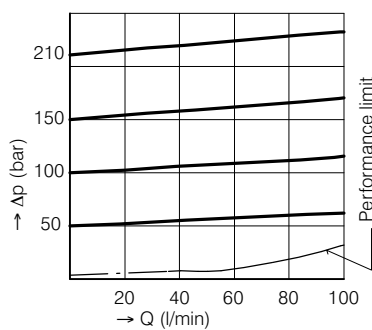

Δp -Q characteristic
DVPA-RV-1-10-...L

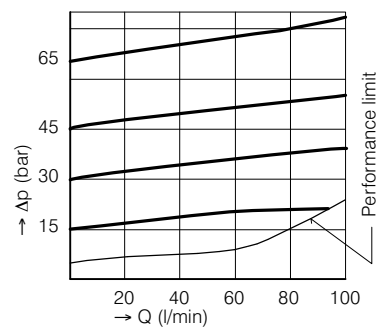

Δp -Q for check valve

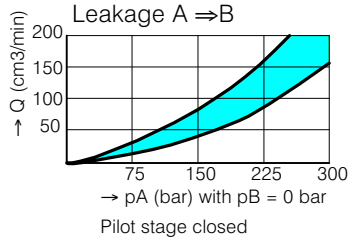
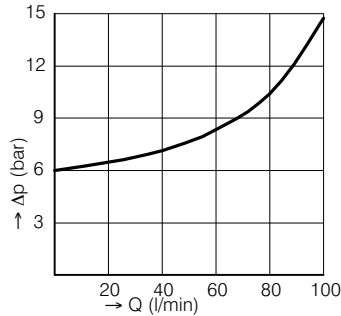

Rate of pressure change when turning the adjusting screw

DVPA-RV-1-10-...N: 1 turn	≅ approx. 65 bar
DVPA-RV-1-10-...M: 1 turn	≅ approx. 38 bar
DVPA-RV-1-10-...L: 1 turn	≅ approx. 13 bar

5. Dimensions

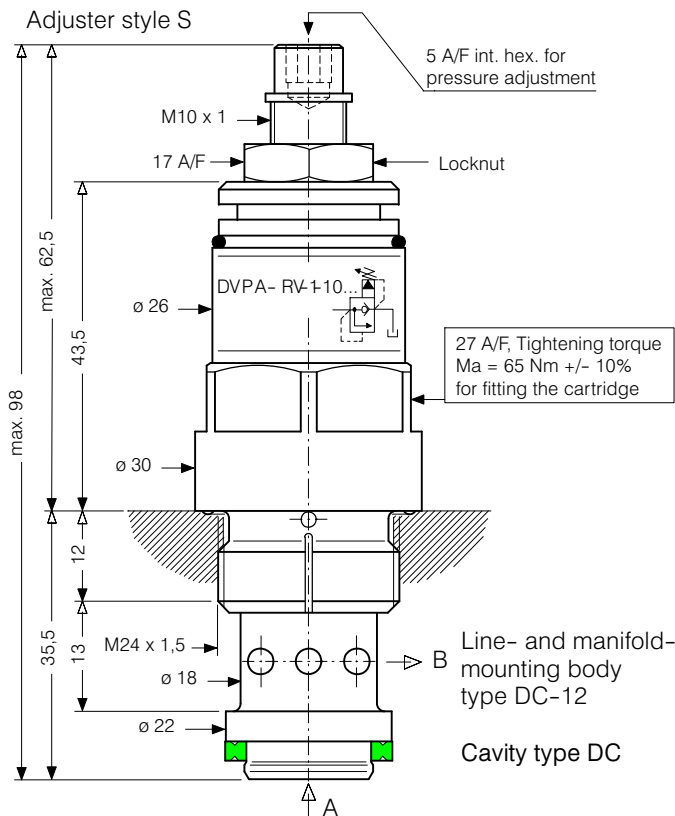

Adjuster styles / OPTIONAL

Cartridges can also be supplied with adjuster styles H and Z4 (see model code key)

Adjuster style H Hand knob

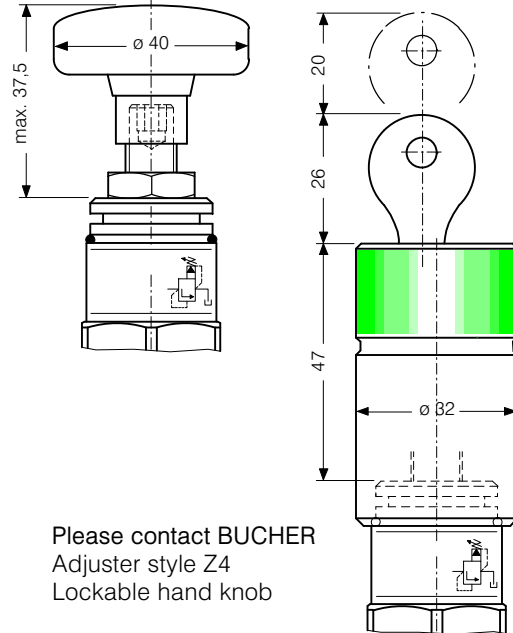

Please contact BUCHER
Adjuster style Z4
Lockable hand knob

6. Schematic section

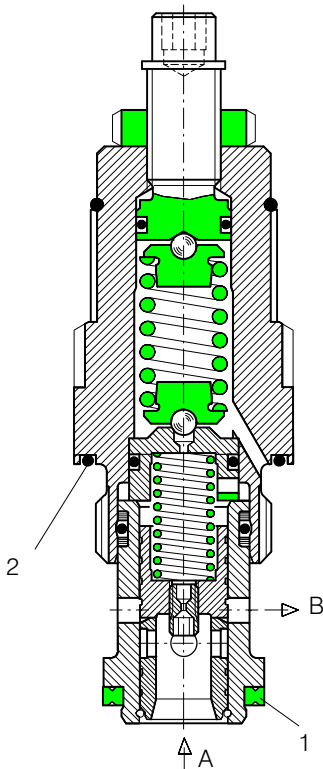

Seal kit no. DS-216-N, comprising:

Itm.	Qty.	Description	Size
1	1	Sealing ring	Ø 22,1 / 16,5 x 2,5
2	1	O-ring no. 021	Ø 23,52 x 1,78 N90

7. Installation and servicing

All installation and servicing must be carried out with care, and by qualified personnel only. Use the correct tightening torque when fitting the cartridge. When changing seals, the

new seals must be thoroughly oiled or greased before they are fitted.

8. Model code key

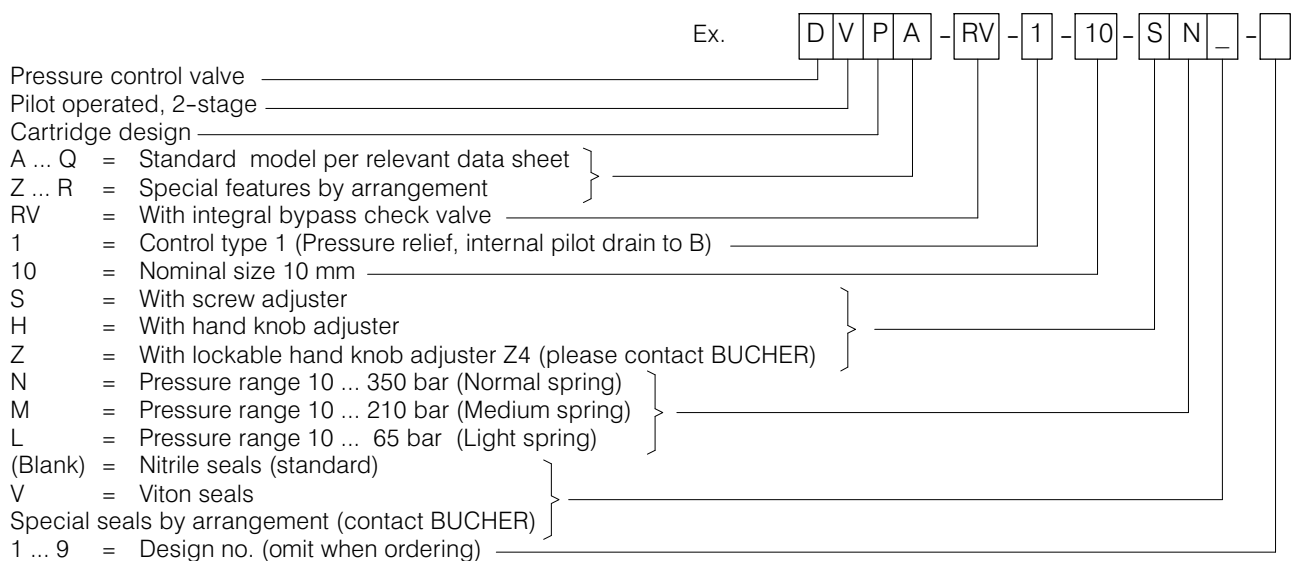

9. Related data sheets

Old no.	New no.	
D-4.31	400-P-280101-EN	Pressure relief cartridge valve without integral bypass check valve type DVPA-1-10 ...
G-24.20	400-P-740101-EN	BUCHER Line- and manifold-mounting body type DC-12 (G 1/2")
i-32	400-P-040011-EN	The Form tool hire programme
i-45.1	400-P-060111-EN	BUCHER cavity type DC

info.ch@bucherhydraulics.com

www.bucherhydraulics.com

© 2015 by Bucher Hydraulics AG Frutigen, CH-3714 Frutigen

All rights reserved.

Data is provided for the purpose of product description only, and must not be construed as warranted characteristics in the legal sense. The information does not relieve users from the duty of conducting their own evaluations and tests. Because the products are subject to continual improvement, we reserve the right to amend the product specifications contained in this catalogue.

Classification: 450300.305.320.355