



Electronic Pressure Switch EDS 710

(Minimum order quantity 100 units)

Description:

The electronic pressure switch EDS 710 has been specially developed for use in large volume production machines.

The highly compact unit has a very robust pressure sensor with thin-film strain gauge on a stainless steel membrane.

The EDS 710 is available with 1 transistor switching output (PNP) which can be defined either as N/C or N/O.

Switching and switch-back points of the EDS 710 are factory-set according to customer specification (not field-adjustable).

Various pressure ranges between 0 .. 16 bar and 0 .. 600 bar are available.

Special features:

- 1 transistor switch output (PNP), either as N/C or N/O
- Factory-set according to customer specification (not field-adjustable)
- Accuracy $\leq \pm 1\%$ FS
- Highly robust sensor cell
- Highly compact design
- Very small temperature error

Technical data:

Input data	
Measuring ranges	16; 60; 100; 250; 400; 600 bar
Overload pressures	32; 200; 200; 500; 800; 1000 bar
Burst pressures	200; 500; 500; 1000; 2000; 2000 bar
Mechanical connection	G1/4 A DIN 3852
Torque value	20 Nm
Parts in contact with medium	Mech. conn.: Stainless steel Seal: FPM
Output data	
Switch output	1 transistor switching output (N/C or N/O)
Output load	400 mA
Switching points	according to customer specification
Switch-back points	according to customer specification
Accuracy to DIN 16086, Max. setting	$\leq \pm 0.5\%$ FS typ. $\leq \pm 1\%$ FS max.
Repeatability (at 25 °C)	$\leq \pm 0.1\%$ FS max.
Temperature drift	$\leq \pm 0.03\%$ FS / °C max. zero point $\leq \pm 0.03\%$ FS / °C max. range
Rising switch point and falling switch point delay	8 ms to 2000 ms (standard 32 ms); factory-set according to customer spec.
Long-term drift	$\leq \pm 0.3\%$ FS typ. / year
Environmental conditions	
Compensated temperature range	-25 .. +85 °C
Operating temperature range ¹⁾	-40 .. +85 °C / -25 .. +85 °C
Storage temperature range	-40 .. +100 °C
Fluid temperature range ¹⁾	-40 .. +100 °C / -25 .. +100 °C
CE mark	EN 61000-6-1 / 2 / 3 / 4
Vibration resistance to DIN EN 60068-2-6 at 10 .. 500 Hz	≤ 20 g
Shock resistance to DIN EN 60068-2-29 (1 ms)	≤ 100 g
Protection class to IEC 60529	IP 67
Other data	
Electrical connection ²⁾	e.g. M12x1 (4 pole) Flying leads
Supply voltage	10 .. 30 V DC
Residual ripple of supply voltage	$\leq 5\%$
Life expectancy	> 10 million cycles 0 .. 100 % FS
Weight	~ 60 g

Note: Reverse polarity protection of the supply voltage, excess voltage, override, short-circuit protection are provided.

FS (Full Scale) = relative to complete measuring range

¹⁾ -25 °C with FPM seal, -40 °C on request

²⁾ Other electrical connection options, e.g. cables with different types of connector, available on request.

Dimensions (examples):

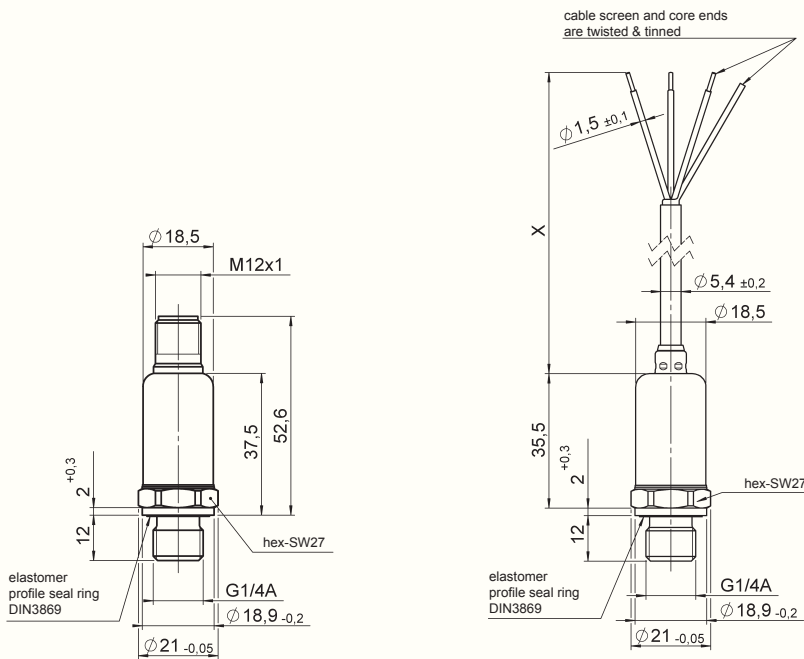

Note:

The information in this brochure relates to the operating conditions and applications described. For applications or operating conditions not described, please contact the relevant technical department. Subject to technical modifications.

Order details:

The electronic pressure switch EDS 710 has been specially developed for OEM customers and is available for minimum order quantities of 100 pieces per type. For precise specifications, please contact the Sales Department of HYDAC ELECTRONIC.

HYDAC ELECTRONIC GMBH
Hauptstraße 27, D-66128 Saarbrücken
Telephone +49 (0)6897 509-01
Fax +49 (0)6897 509-1726
E-mail: electronic@hydac.com
Internet: www.hydac.com