

Electro-Mechanical Flow Switch HFS 2500 for Water or Water-Based Media

Description:

The HYDAC Flow Switch in the series HFS 2500 is based on the variable area float principle. The test medium deflects a spring-loaded float in the direction of flow, depending on the flow rate. A reed contact is fitted to the outside of the instrument and is therefore separate from the flow circuit. When the magnet inside the float reaches the pre-set position, the reed contact will switch. To protect it from external influences, the switch is encapsulated in a casing designed to allow steplessly variable adjustment.

The instruments in the HFS 2500 series are available in two versions, with 5% accuracy and with 10% accuracy. Areas of application are to monitor flow rate in fluids (water / water-based) in the following areas, amongst others:

- Cooling systems and circuits
- Hydraulic systems
- Pumps
- Welding machines and laser systems
- Medical technology
- Pharmaceutical industry
- Chemical industry
- Research & development

Fluid:

- Water / water-based media

Special features:

- Accuracy $\leq \pm 5\%$ or $\leq \pm 10\%$ FS
- Any mounting position
- High level of function reliability
- High level of switching accuracy
- Stepless switch point setting by user
- High pressure resistance
- Threaded connection
- ATEX version also available for potentially explosive atmospheres

Note: FS (Full Scale) = relative to complete measuring range

1) Other seal materials available on request

2) The contact opens / switches when the flow falls below the pre-set switching point.

3) Minimum load 3 VA

Technical data:

Input data					
Switching ranges [l/min]	5 % accuracy		10 % accuracy		
			Size 1	Size 2	Size 3
0.2 .. 4.0	8 .. 90		0.005..0.06	0.02 .. 0.2	10 .. 30
0.6 .. 5.0	5 .. 110		0.04 .. 0.13	0.2 .. 0.6	15 .. 45
0.5 .. 8.0	10 .. 150		0.1 .. 0.6	0.4 .. 1.8	20 .. 60
1 .. 14	35 .. 220		0.2 .. 1.2	0.8 .. 3.2	30 .. 90
1 .. 28	35 .. 250		0.4 .. 2.0	2 .. 7	60 .. 150
2 .. 40			0.5 .. 3.0	3 .. 13	
4 .. 55			1.0 .. 5.0	4 .. 20	
1 .. 70				8 .. 30	
Operating pressure					
Brass version	200 bar		300 bar	300 bar	250 bar
Stainless steel version	300 bar		350 bar	350 bar	300 bar
Pressure drop [bar]	0.02 .. 0.8		0.02 .. 0.2	0.02 .. 0.3	0.02 .. 0.4
Mechanical connection	See dimensions				
Parts in contact with medium					
Brass version	Stainless steel 1.4571; NBR ¹⁾ ; Brass; nickel-plated; Brass; Hard ferrite				
Stainless steel version	Stainless steel 1.4571; FPM ¹⁾ ; Hard ferrite				
Output data					
Switching outputs ²⁾	1 or 2 reed contacts Change-over or N/O type ²⁾				
Accuracy	$\leq \pm 5\%$ or $\leq \pm 10\%$ FS				
Repeatability	2 % FS max.				
Switching capacity					
Change-over contact ³⁾	max.	max.	max.	max.	
Male connection	- 250 V	- 200 V	- 250 V	- 250 V	
EN175301-803 (DIN 43650)	- 1.5 A	- 1 A	- 1.5 A	- 1.5 A	
	- 50 VA	- 20 VA	- 50 VA	- 50 VA	
Male connection M12x1	max.	max.	max.	max.	
	- 250 V	- 125 V	- 125 V	- 250 V	
	- 1.5 A	- 1 A	- 1.5 A	- 1.5 A	
	- 50 VA	- 20 VA	- 50 VA	- 50 VA	
N/O contact	max.	max.	max.	max.	
Male connection	- 250 V	- 200 V	- 230 V	- 250 V	
EN175301-803 (DIN 43650)	- 3 A	- 1 A	- 3 A	- 3 A	
	- 100 VA	- 20 VA	- 60 VA	- 100 VA	
Male connection M12x1	max.	max.	max.	max.	
	- 250 V	- 125 V	- 125 V	- 250 V	
	- 3 A	- 1 A	- 3 A	- 3 A	
	- 100 VA	- 20 VA	- 60 VA	- 100 VA	
Environmental Conditions					
Operating temperature range	-20 .. + 70 °C				
Fluid temperature range					
Male connection					
EN175301-803 (DIN 43650)	-20 .. +100 °C (optional -20 .. +160 °C)				
Male connection M12x1	-20 .. +85 °C				
CE mark					
Directive 2006 / 95 / EC Directive 2004 / 108 / EC					
Protection class to IEC 60529	IP 65				
Other data					
Housing material	Brass (nickel-plated) or stainless steel 1.4571				
Electrical connection	Male connection EN175301-803 (DIN 43650) Male connection M12x1				

Model code:

HFS 2 5 X X - XX - XXXX-XXXX - X - X - X - 000

Measuring principle

2 = Variable area float

Test medium

5 = Water or water-based

Mechanical connection

4)5)

1 = 1/4 "

2 = 3/8 "

3 = 1/2 "

4 = 3/4 "

5 = 1 "

6 = 1 1/4 "

7 = 1 1/2 "

Electrical connection

5 = Male EN175301-803

(DIN 43650)

3 pole + PE

(connector supplied)

6 = Male M12x1, 4-pole

(connector not supplied)

Switching contacts

1S = 1 N/O contact

2S = 2 N/O contacts

1W = 1 Change-over contact

2W = 2 Change-over contacts

Switching ranges in l/min

Water 5 %

00.2-04.0; 00.6-05.0; 00.5-08.0;

01.0-0014; 01.0-0028; 02.0-0040; 04.0-0055;

01.0-0070; 08.0-0090; 0005-0110; 0010-0150;

0035-0220; 0035-0250;

Water 10 % - Size 1 - (only available without mech. indicator)

.005-0.06; 0.04-0.13; 00.1-00.6; 00.2-01.2;

00.4-02.0; 00.5-03.0; 01.0-05.0

Water 10 % - Size 2 -

0.02-00.2; 00.2-00.6; 00.4-01.8; 00.8-03.2;

02.0-07.0; 03.0-0013; 04.0-0020; 08.0-0030

Water 10 % - Size 3 -

0010-0030; 0015-0045; 0020-0060;

0030-0090; 0060-0150

Accuracy

6 = $\leq \pm 5.0$ % FS

7 = $\leq \pm 10.0$ % FS

Housing material

B = Brass (nickel-plated)

S = Stainless steel

Mechanical indicator

0 = Without indicator

1 = With indicator

Modification number

000 = Standard

4) Mechanical connection options depend on housing type (see Dimensions)

5) Other models available on request.

6) When the model with 2 switching contacts is selected, the second contact is fitted on the side of the instrument at 90° to the first contact.

Note:

On instruments with a different modification number, please read the label or the technical amendment details supplied with the instrument.

Accessories:

Appropriate accessories, such as electrical connectors, can be found in the Accessories brochure.

Pin connections:

EN175301-803 (DIN 43650)

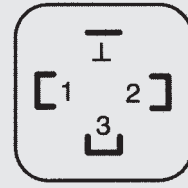

Pin	HFS 25X5-XS	HFS 25X5-XW
1	Centre	Centre
2	N/O contact	N/C contact
3	n.c.	N/O contact
⊥	Housing	Housing

M12x1

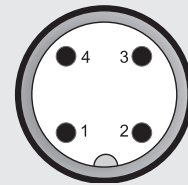

Pin	HFS 25X6-XS	HFS 25X6-XW
1	Centre	Centre
2	n.c.	N/C contact
3	n.c.	n.c.
4	N/O contact	N/O contact

Notes on installation:

- The medium must not contain solid particles! We recommend using contamination strainers.
- External magnetic fields can affect the switching contact. Ensure sufficient distance from magnetic fields (e.g. from electric motors)!

Dimensions without indicator:

Type [l/min]	Installation dimensions [mm]							Weight (approx.) [g]
	SW	D	B	G	DN	T	L	

Water 5 % Accuracy

0.2 .. 4.0	27	30	86	1/4" 3/8" 1/2"	8 10 15	14	130	850
0.6 .. 5.0								
0.5 .. 8.0								
1 .. 14								
1 .. 28	27	30	86	1/2" 3/4"	15 20	14 16	148 174	900
2 .. 40								
4 .. 55								
1 .. 70	34 40	40 40	96 96	3/4" 1"	20 25	18 19	152 156	1400 1100
8 .. 90								
5 .. 110								
10 .. 150	50	50	101	1 1/4"	32	21	200	2750
35 .. 220	50	50	106	1 1/4"	32	21	200	3000
35 .. 250	60	50	107	1 1/2"	40	24	200	3800

Water 10 % Accuracy - Size 1-

0.005..0.06	17	18	56	1/4"	8	10	65	140
0.04..0.13								
0.1..0.6								
0.2..1.2								
0.4..2.0								
0.5..3.0								
1.0..5.0								

Water 10 % Accuracy - Size 2 -

0.02 .. 0.2	27	31	67	1/2 "	15	15	90	350
0.2 .. 0.6								
0.4 .. 1.8								
0.8 .. 3.2								
2.0 .. 7.0								
3.0 .. 13.0								
4.0 .. 20.0								
8.0 .. 30.0								

Water 10 % Accuracy - Size 3 -

10 .. 30	41	47	93	3/4 " 1" *)	20 25	21 17	152 130	1200 1050
15 .. 45								
20 .. 60								
30 .. 90								
60 .. 150	41	47	93	1"	25	17	130	1050

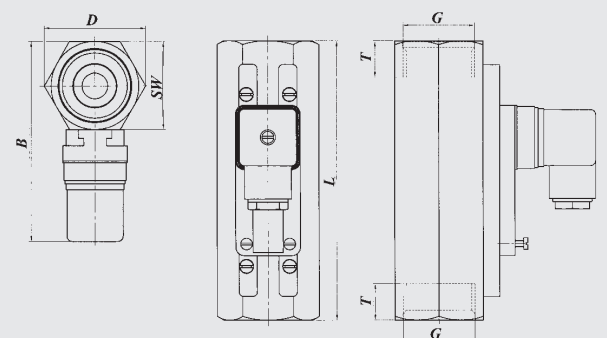
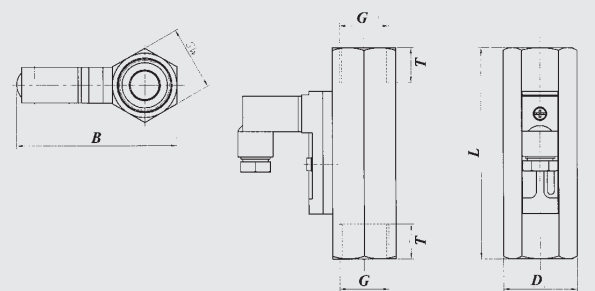
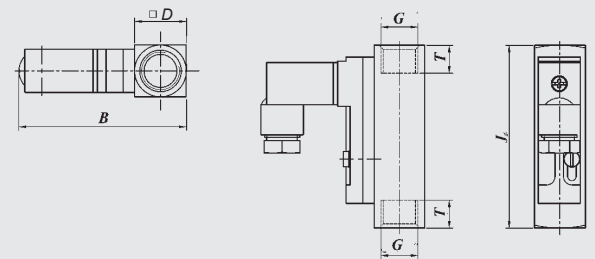
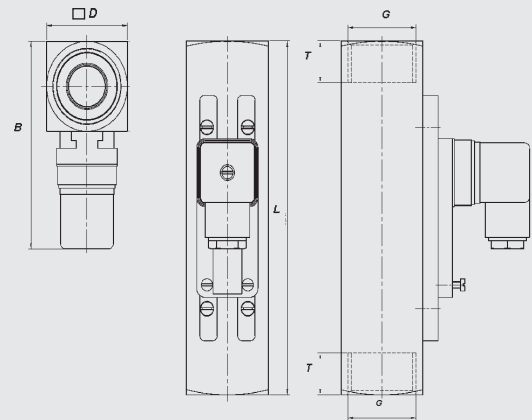

*) Standard

Dimensions with indicator:

Type [l/min]	Installation dimensions [mm]							Weight (approx.) [g]
	SW	D	B	G	DN	T	L	

Water 5 % Accuracy

0.2 .. 4.0	27	30	86	1/4" 3/8" 1/2"	8 10 15	14	130	940
0.6 .. 5.0								
0.5 .. 8.0								
1 .. 14								
1 .. 28	27	30	86	1/2" 3/4"	15 20	14 16	148 174	990
2 .. 40								
4 .. 55								
1 .. 70	34	40	96	3/4"	20	18	152	1490
8 .. 90								
5 .. 110	40	40	96	1"	25	19	156	1190
10 .. 150	50	50	101	1 1/4"	32	21	200	2840
35 .. 220	50	50	106	1 1/4"	32	21	200	3090
35 .. 250	60	50	107	1 1/2"	40	24	200	3890

Water 10 % Accuracy - Size 2-

0.02 .. 0.2	30	30	70	1/2 "	15	15	90	570
0.2 .. 0.6								
0.4 .. 1.8								
0.8 .. 3.2								
2.0 .. 7.0								
3.0 .. 13.0								
4.0 .. 20.0								
8.0 .. 30.0								

Water 10 % Accuracy - Size 3 -

10 .. 30	41	47	93	3/4 " 1" *)	20 25	21 17	152 130	1430 1250
15 .. 45								
20 .. 60								
30 .. 90								
60 .. 150	41	47	93	1"	25	17	130	1250

*) Standard

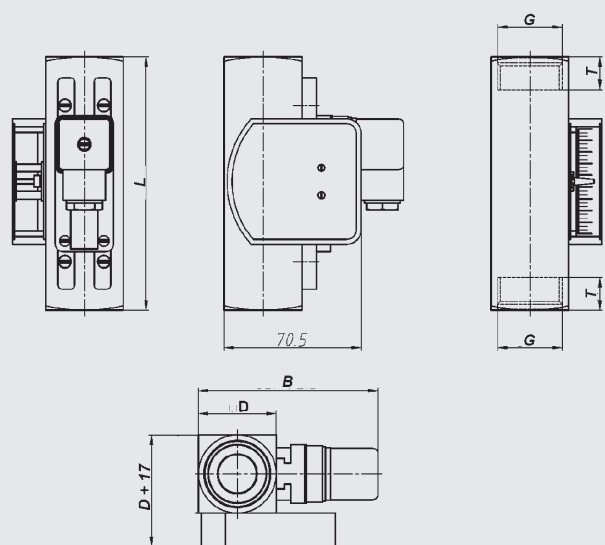
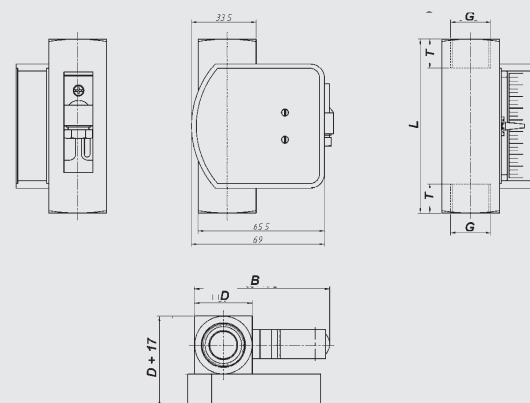
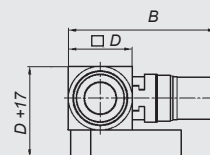
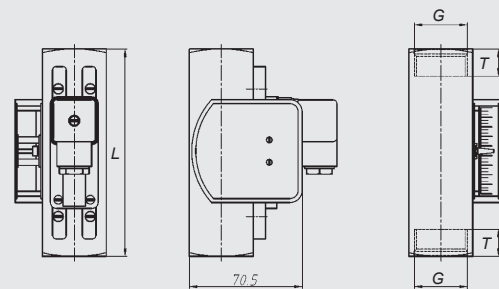

Note:

The information in this brochure relates to the operating conditions and applications described.
For applications or operating conditions not described, please contact the relevant technical department.
Subject to technical modifications.

HYDAC ELECTRONIC GMBH

Hauptstraße 27, D-66128 Saarbrücken
Telephone +49 (0)6897 509-01
Fax +49 (0)6897 509-1726
E-mail: electronic@hydac.com
Internet: www.hydac.com