



## 6.1 SIZE 1 CONTENTS

PGE101

<b>Ordering Code</b>	6.2.1 External Gear Pump
<b>Technical Information</b>	6.2.2 Specifications 6.2.3 Hydraulic fluids 6.2.4 Viscosity range 6.2.5 Temperature range 6.2.6 Seals 6.2.7 Filtration 6.2.8 Installation notes
<b>Dimensions</b>	6.2.9 Drive shafts 6.2.10 Mounting flange 6.2.11 Ports 6.2.12 Preferred series

# ORDERING CODE

## 6.2.1 External Gear Pump

PGE101 – 100 – R B Q 1 – N – XXXX

External gear pump  
Size 1

**Displacement**

100	1	cm <sup>3</sup> /rev
125	1.25	cm <sup>3</sup> /rev
160	1.6	cm <sup>3</sup> /rev
200	2	cm <sup>3</sup> /rev
250	2.5	cm <sup>3</sup> /rev
315	3.15	cm <sup>3</sup> /rev
365	3.65	cm <sup>3</sup> /rev
420	4.2	cm <sup>3</sup> /rev
500	5	cm <sup>3</sup> /rev
610	6.1	cm <sup>3</sup> /rev
740	7.4	cm <sup>3</sup> /rev

**Shaft rotation (viewed from shaft end)**

- R Clockwise
- L Anti-clockwise

**Shaft**

- A Tapered keyed shaft 1:5
- B Tapered keyed shaft 1:8
- C Tang
- Z Special shaft (only on request)

**Mounting flange**

- L 2-hole mounting, centering Ø 32 mm
- M 2-hole mounting, centering Ø 32 mm with O-ring
- Q Square flange centering Ø 25.4 mm
- Z Special flange (only on request)

**Ports**

- 1 Pipe thread ISO 228-1
- 2 Metric thread DIN 3852-1
- 3 Thread UN 2B SAE O-ring boss
- 4 Square flange (ital. design)
- 5 Square flange DIN 3901/ ISO 8435
- 9 Special ports (only on request)

**Seals**

- N NBR
- V FPM

**Modification number**

- XXXX Determined by manufacturer

Not all combinations in the ordering code are possible.  
Please refer to 6.2.12 Preferred series, or consult HYDAC.  
Special options are possible upon request.

# TECHNICAL INFORMATION

## 6.2.2 Specifications

Pump size		100	125	160	200	250	315	365	420	500	610	740	
Geometric displacement		[cm <sup>3</sup> /rev]	1	1.25	1.6	2	2.5	3.15	3.65	4.2	5	6.1	7.4
Pressure	Rated	[bar]	250								200	170	
	Intermittent		280								220	190	
	Peak		300								230	200	
Drive speed	min.	[rpm]	750										
	max.		3500						3000	2500	2500		
Approx. weight		[kg]	1	1.02	1.04	1.05	1.07	1.11	1.14	1.18	1.25	1.3	1.37

The continuous and maximum pressures given here only apply to pumps with flange ports. If threaded ports are required, the performance will be reduced. To find out whether a pump with threaded ports can be used in a high pressure application, please consult HYDAC.

## 6.2.3 Hydraulic fluids

The pump series is designed for use with

**HL** Hydraulic oil  
(normal mineral oil)  
and

**HLP** Hydraulic oils of the R&O type  
(Rust and Oxidation inhibitor)

## 6.2.4 Viscosity range

**Normal** operating viscosity:  
16 - 200 cSt (mm<sup>2</sup>/s)

For other viscosity ranges, please contact HYDAC.

## 6.2.5 Temperature range

Ambient temperature range  
**-22 to 55 °C**

Fluid temperature range  
NBR

**-25 up to 85 °C**

Viton

**-15 up to 90 °C**

### 6.2.6 Seals

The pump series is equipped with NBR seals.

If special hydraulic fluids are used, the seal material must be changed if required. Please contact HYDAC.

### 6.2.7 Filtration

For maximum service life of the pump and system components, the system should be protected from contamination by effective filtration. Cleanliness class:

**21/ 18/ 15 to ISO 4406:1999**

or

**Class 9 to NAS 1638 or cleaner.**

At system pressures above 160 bar cleanliness class:

**19/17/14 to ISO 4406:1999**

or

**Class 8 to NAS 1638** is required.

### 6.2.8 Installation notes

#### A. Mounting

The pump can be installed horizontally or vertically with the shaft at the top. If the pump is installed on the tank or above the oil level, the distance between the pump inlet and the oil level should not exceed 1 metre.

When installing a HYDAC pump always ensure that the fluid remains in the pump during stoppages.

#### B. Suction pipe

If the pump is installed above the oil level, particular attention must be paid to the suction pressure. The cross-section of the suction pipe must be equal to or larger than the cross-section of the pump port. The suction pressure must be kept within the values specified.

Minimum suction pressure:  
0.8 bar abs.

Maximum suction pressure:  
2.2 bar abs.

#### C. Drive

**Use a flexible coupling whenever possible. There must not be any radial or axial forces on the pump shaft. The maximum misalignment of the shafts is 0.2 mm and the angular deviation must be less than 0.2°.**

Drive shafts with tang are for direct mounting onto an electric motor or a gearbox. The driver for the tang is not included.

For indirect drives (with gear, chain or belt drives) please consult Hydac.

# DIMENSIONS

## 6.2.9 Drive shafts

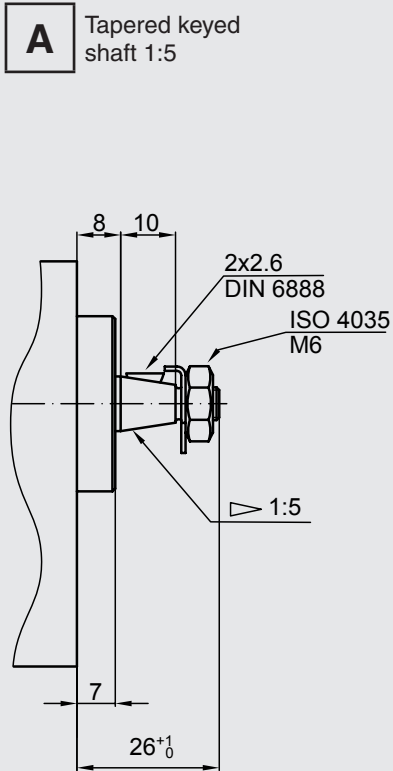

relevant mounting flange **L**

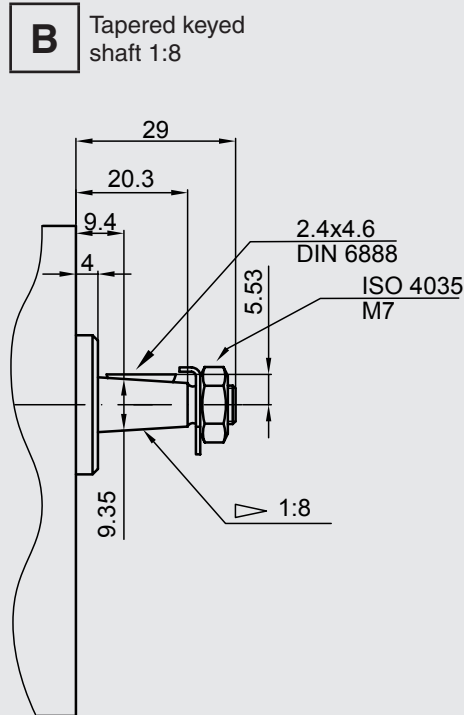

relevant mounting flange **Q**

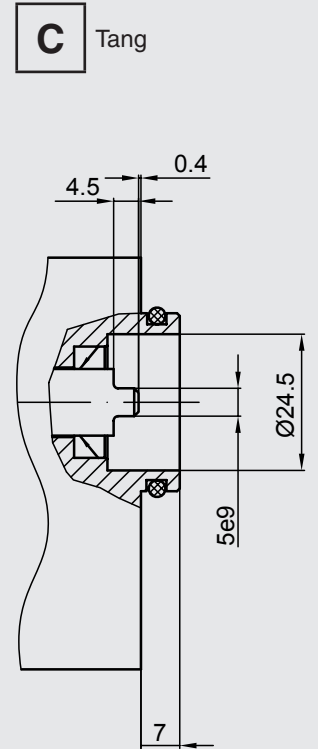

relevant mounting flange **M**

## 6.2.10 Mounting flange

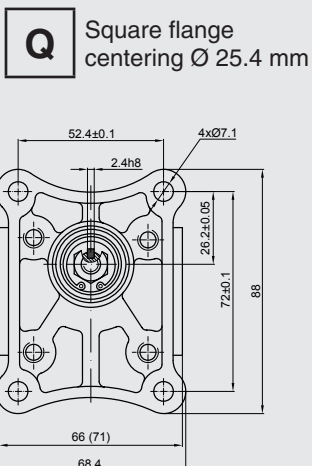
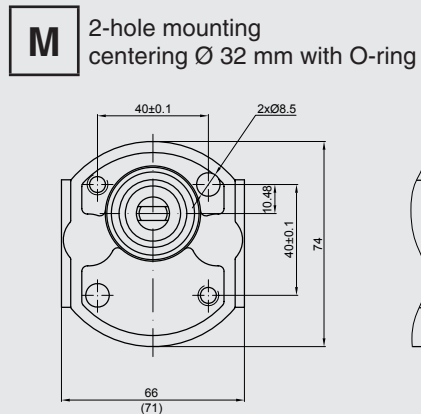
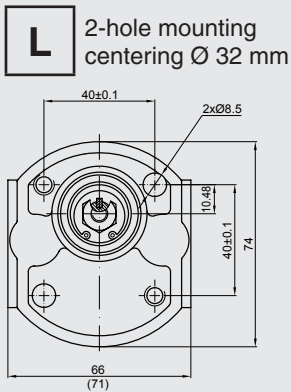

## 6.2.11 Ports

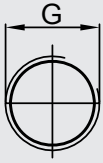

### 1 Pipe thread ISO 228/1

Ordering code	Displacement	Outlet G	Inlet G
1	1 ... 2.5 cm <sup>3</sup>	G 3/8	G 3/8
	3.15 ... 7.4 cm <sup>3</sup>	G 3/8	G 1/2

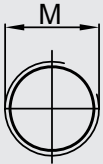

### 2 Metric thread DIN 3852-1

Ordering code	Displacement	Outlet M	Inlet M
2	1 ... 2.5 cm <sup>3</sup>	M16x1.5	M16x1.5
	3.15 ... 6.1 cm <sup>3</sup>	M16x1.5	M20x1.5
	7.4 cm <sup>3</sup>	M18x1.5	M22x1.5

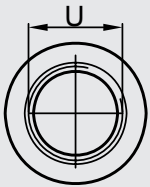

### 3 Pipe thread UN 2B SAE O-ring boss

Ordering code	Displacement	Outlet U	Inlet U
3	1 ... 6.1 cm <sup>3</sup>	9/16-18 UNF	3/4-16 UNF
	7.4 cm <sup>3</sup>	3/4 16 UNF	7/8-14 UNF

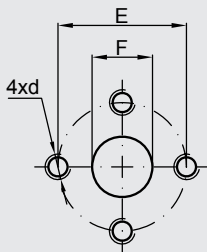

### 4 Square flange (Italian design)

Ordering code	Displacement	Outlet			Inlet		
		F	E	d	F	E	d
4	1 ... 7.4 cm <sup>3</sup>	12	30	M6	12	30	M6

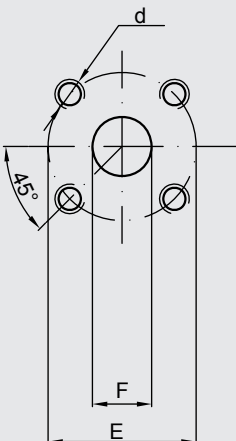

### 5 Square flange DIN 3901/ ISO 8435

Ordering code	Displacement	Outlet			Inlet		
		F	E	d	F	E	d
5	1 ... 7.4 cm <sup>3</sup>	12	30	M6	12	30	M6

6.2.12 Preferred series

PGE101-....BQ1-N

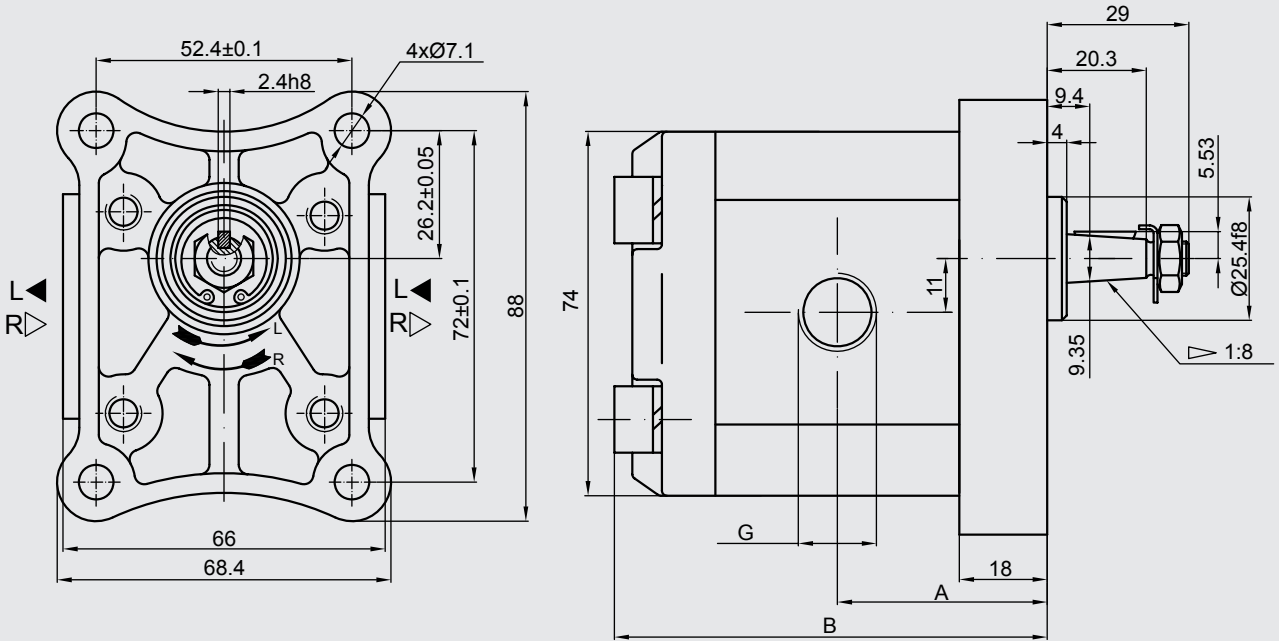

Type	Displacement [cm <sup>3</sup> /rev]	Output flow		Rated [bar]	Max. speed n [rpm]	Dimension			
		at 1500 rpm [l/min]	at max. rpm [l/min]			A [mm]	B [mm]	Inlet G	Outlet G
PGE101-100-. BQ1-N	1	1.40	3.26	250	3500	39.1	81	G 3/8"	G 3/8"
PGE101-125-. BQ1-N	1.25	1.74	4.07			39.5	82		
PGE101-160-. BQ1-N	1.6	2.23	5.21			40.3	83.6		
PGE101-200-. BQ1-N	2	2.82	6.58			41.1	85.2		
PGE101-250-. BQ1-N	2.5	3.53	8.23			42.1	87.2		
PGE101-315-. BQ1-N	3.15	4.44	10.36			43.5	89.8		
PGE101-365-. BQ1-N	3.65	5.15	12.01			44.4	91.9		
PGE101-420-. BQ1-N	4.2	5.92	13.82			45.5	94.1		
PGE101-500-. BQ1-N	5	7.05	14.10			47.1	97.2	G 1/2"	
PGE101-610-. BQ1-N	6.1	8.69	14.49			49.4	101.8		
PGE101-740-. BQ1-N	7.4	10.55	17.58	170	2500	52.1	107.2		

PGE101-...-BQ4-N

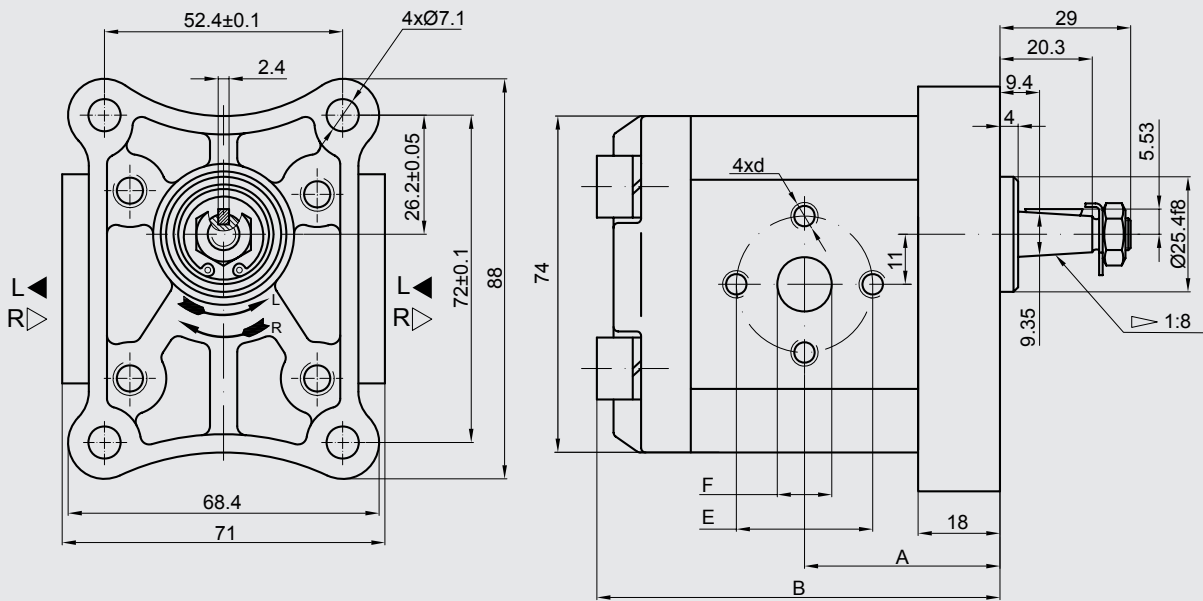

Type	Displacement [cm <sup>3</sup> /rev]	Output flow		Rated [bar]	Max. speed n [rpm]	Dimension							
		at 1500 rpm [l/min]	at max. rpm [l/min]			Inlet		Outlet		A [mm]	B [mm]		
						E	F	d	E	F	d		
PGE101-100-. BQ4-N	1	1.40	3.26	250	3500	39.1	81	Ø 30	Ø 12	M6	Ø 30	Ø 12	M6
PGE101-125-. BQ4-N	1.25	1.74	4.07			39.5	82						
PGE101-160-. BQ4-N	1.6	2.23	5.21			40.3	83.6						
PGE101-200-. BQ4-N	2	2.82	6.58			41.1	85.2						
PGE101-250-. BQ4-N	2.5	3.53	8.23			42.1	87.2						
PGE101-315-. BQ4-N	3.15	4.44	10.36			43.5	89.8						
PGE101-365-. BQ4-N	3.65	5.15	12.01			44.4	91.9						
PGE101-420-. BQ4-N	4.2	5.92	13.82			45.5	94.1						
PGE101-500-. BQ4-N	5	7.05	14.10			47.1	97.2						
PGE101-610-. BQ4-N	6.1	8.69	14.49			200	3000						
PGE101-740-. BQ4-N	7.4	10.55	17.58	170	2500	52.1	107.2						



PGE101-....AL1-N

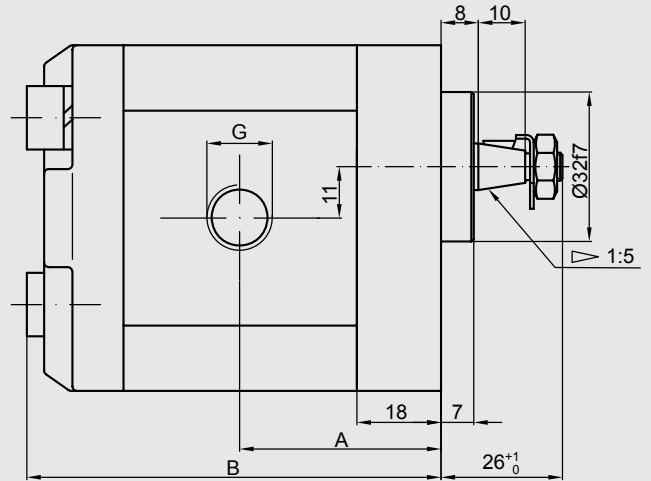
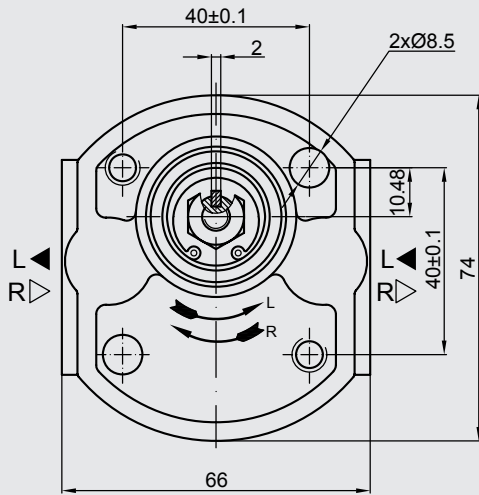

Type	Displacement [cm <sup>3</sup> /rev]	Output flow		Rated [bar]	Max. speed n [rpm]	Dimension			
		at 1500 rpm [l/min]	at max. rpm [l/min]			A [mm]	B [mm]	Inlet G	Outlet G
PGE101-100-. AL1-N	1	1.40	3.26	250	3500	39.1	81	G 3/8"	G 3/8"
PGE101-125-. AL1-N	1.25	1.74	4.07			39.5	82		
PGE101-160-. AL1-N	1.6	2.23	5.21			40.3	83.6		
PGE101-200-. AL1-N	2	2.82	6.58			41.1	85.2		
PGE101-250-. AL1-N	2.5	3.53	8.23			42.1	87.2		
PGE101-315-. AL1-N	3.15	4.44	10.36			43.5	89.8		
PGE101-365-. AL1-N	3.65	5.15	12.01			44.4	91.9		
PGE101-420-. AL1-N	4.2	5.92	13.82			45.5	94.1		
PGE101-500-. AL1-N	5	7.05	14.10			47.1	97.2		
PGE101-610-. AL1-N	6.1	8.69	14.49			200	3000		
PGE101-740-. AL1-N	7.4	10.55	17.58	170	2500	52.1	107.2		

PGE101-...-AL5-N

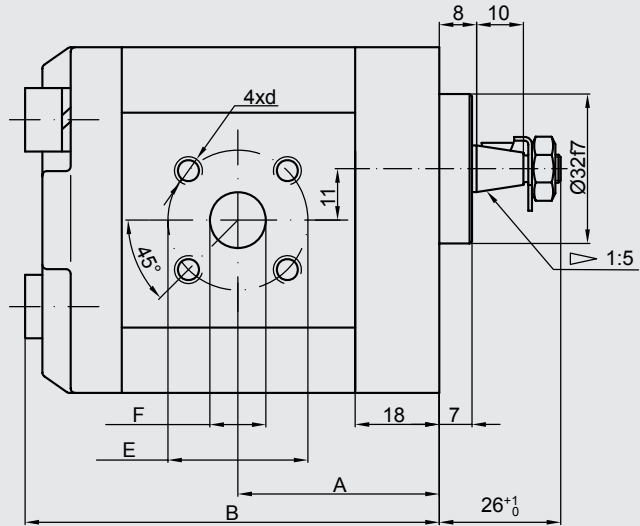
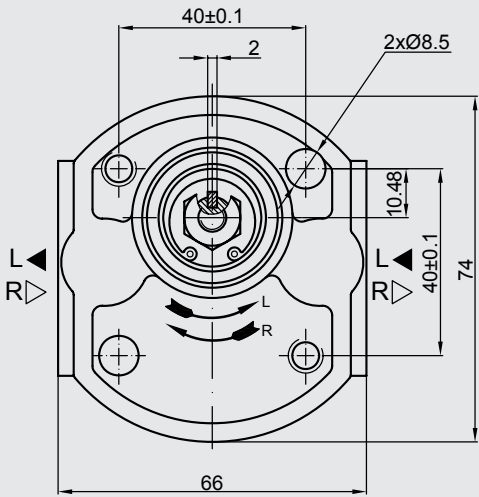

Type	Displacement [cm <sup>3</sup> /rev]	Output flow		Rated [bar]	Max. speed n [rpm]	Dimension							
		at 1500 rpm [l/min]	at max. rpm [l/min]			Inlet		Outlet		A [mm]	B [mm]		
						E	F	d	E	F	d		
PGE101-100-.AL5-N	1	1.40	3.26	250	3500	Ø 30	Ø 12	M6	Ø 30	Ø 12	M6	39.1	81
PGE101-125-.AL5-N	1.25	1.74	4.07									39.5	82
PGE101-160-.AL5-N	1.6	2.23	5.21									40.3	83.6
PGE101-200-.AL5-N	2	2.82	6.58									41.1	85.2
PGE101-250-.AL5-N	2.5	3.53	8.23									42.1	87.2
PGE101-315-.AL5-N	3.15	4.44	10.36									43.5	89.8
PGE101-365-.AL5-N	3.65	5.15	12.01									44.4	91.9
PGE101-420-.AL5-N	4.2	5.92	13.82									45.5	94.1
PGE101-500-.AL5-N	5	7.05	14.10									47.1	97.2
PGE101-610-.AL5-N	6.1	8.69	14.49									200	3000
PGE101-740-.AL5-N	7.4	10.55	17.58	170	2500	52.1	107.2						

PGE101-....CM1-N

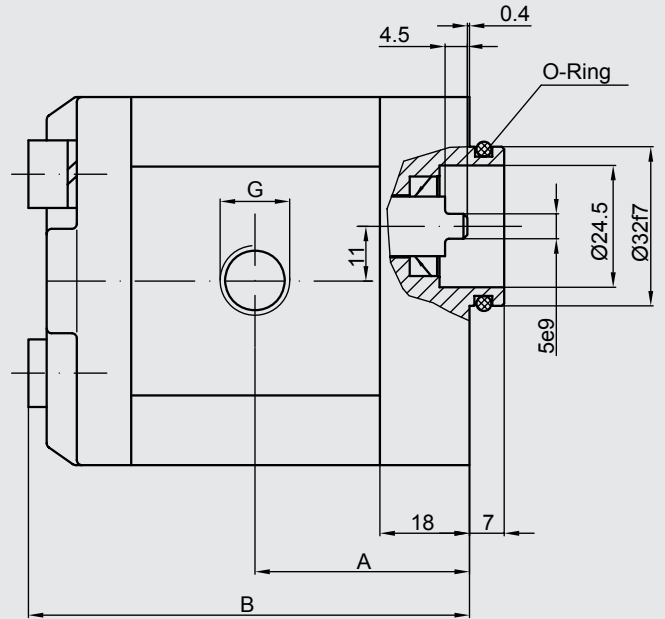
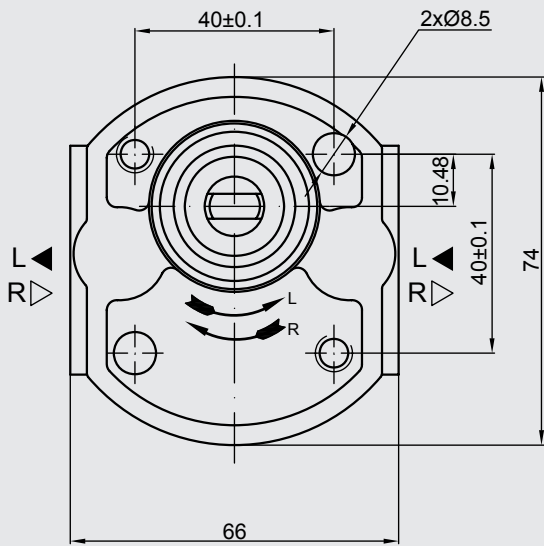

Type	Displacement [cm <sup>3</sup> /rev]	Output flow		Rated [bar]	Max. speed n [rpm]	Dimension			
		at 1500 rpm [l/min]	at max. rpm [l/min]			A [mm]	B [mm]	Inlet G	Outlet G
PGE101-100-. CM1-N	1	1.40	3.26	250	3500	39.1	81	G 3/8"	G 3/8"
PGE101-125-. CM1-N	1.25	1.74	4.07			39.5	82		
PGE101-160-. CM1-N	1.6	2.23	5.21			40.3	83.6		
PGE101-200-. CM1-N	2	2.82	6.58			41.1	85.2		
PGE101-250-. CM1-N	2.5	3.53	8.23			42.1	87.2		
PGE101-315-. CM1-N	3.15	4.44	10.36			43.5	89.8		
PGE101-365-. CM1-N	3.65	5.15	12.01			44.4	91.9		
PGE101-420-. CM1-N	4.2	5.92	13.82			45.5	94.1		
PGE101-500-. CM1-N	5	7.05	14.10			47.1	97.2		
PGE101-610-. CM1-N	6.1	8.69	14.49			200	3000		
PGE101-740-. CM1-N	7.4	10.55	17.58	170	2500	52.1	107.2		

PGE101-...-CM5-N

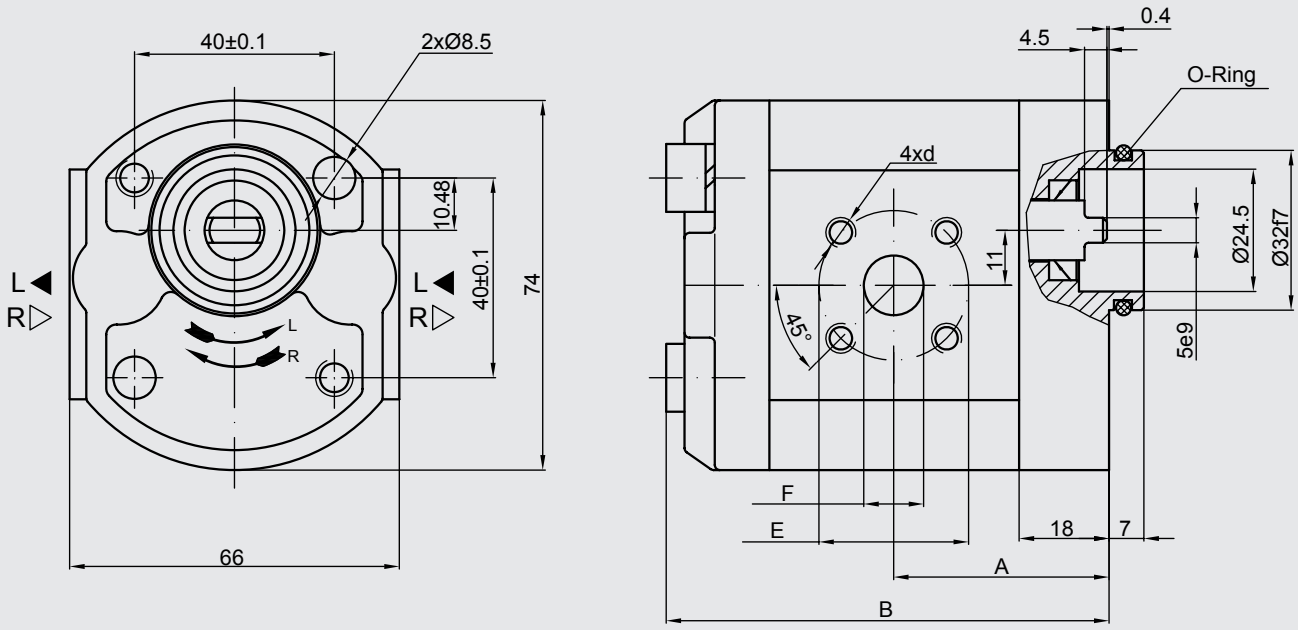

Type	Displacement [cm <sup>3</sup> /rev]	Output flow		Rated [bar]	Max. speed n [rpm]	Dimension							
		at 1500 rpm [l/min]	at max. rpm [l/min]			Inlet			Outlet				
						A [mm]	B [mm]	E	F	d	E	F	d
PGE101-100-. CM5-N	1	1.40	3.26	250	3500	39.1	81	Ø 30	Ø 12	M6	Ø 30	Ø 12	M6
PGE101-125-. CM5-N	1.25	1.74	4.07			39.5	82						
PGE101-160-. CM5-N	1.6	2.23	5.21			40.3	83.6						
PGE101-200-. CM5-N	2	2.82	6.58			41.1	85.2						
PGE101-250-. CM5-N	2.5	3.53	8.23			42.1	87.2						
PGE101-315-. CM5-N	3.15	4.44	10.36			43.5	89.8						
PGE101-365-. CM5-N	3.65	5.15	12.01			44.4	91.9						
PGE101-420-. CM5-N	4.2	5.92	13.82			45.5	94.1						
PGE101-500-. CM5-N	5	7.05	14.10			47.1	97.2						
PGE101-610-. CM5-N	6.1	8.69	14.49			200	3000						
PGE101-740-. CM5-N	7.4	10.55	17.58	170	2500	52.1	107.2						