

Sectional Directional Control Valve RS 270

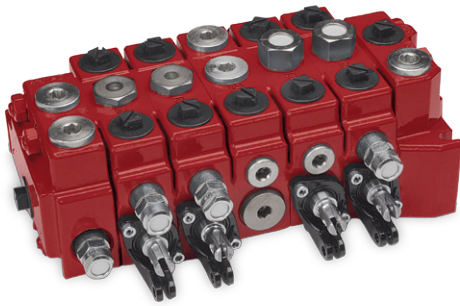

Key valve features

RS 270 is a sectional valve designed for max. operating pressures up to 350 bar and max. pump flows up to 120 l/min.

It is available with 1 to 10 working sections per valve assembly.

RS 270 is designed with an open centre for fixed displacement pumps.

The valve can be operated manually, by pneumatic, electro-pneumatic or hydraulic remote control.

The valve offers excellent operating characteristics because of the specially designed spools for different applications.

Low and uniform spool forces are the result of careful balancing of the flow forces.

Applications

RS 270 is especially suitable in applications where simultaneous operation of several functions is necessary. Typically applications are truck loaders, back-hoe loaders, forest machines and excavators, but also for a number of other machine- and vehicle types.

Further RS 270 properties and possibilities

- Many varieties of spools and spool controls make the valve suitable for a wide range of applications
- Regenerative function
- Possibility of limiting the flow to the service ports in a separate section
- With combination of an intermediate section there is the opportunity to realize different system alternatives, such as tandem circuit, independent or interactive two- or multi circuit systems, supplementary main relief valve, etc.
- Possibility of high pressure carry-over

Technical data

Pressures / Flows	
Max. operating pressure per port:	
P1, P2, PL1, A, B:	350 bar
T1, T2, T3, T4:	20 bar
Max. permissible flow either on port P1 or P2: 120 l/min	
Fluid temperature range: -15 °C up to +80 °C	
Further data	
Spool stroke:	
Nominal:	+/- 8 mm
4:th position:	+14 mm
Spool control force spool control 9:	
Neutral position:	110 N
Max. spool stroke:	140 N
Permissible contamination level: Equal or better than 20/18/14 as per ISO 4406	
Viscosity range: 10 – 400 mm ² /s (cst) Higher viscosity allowed at start up	
Leakage A, B → T at 100 bar, 32 cst and 40 °C: ≤ 18 cc/min	
Pressure fluid: Mineral oil and synthetic oil based on mineral oil HL, HLP according to din 51524	

Higher values are possible, depending on application. For applications with demands that exceed stated data above, please contact us for consideration.

MTTFd value after consultation with HYDAC.

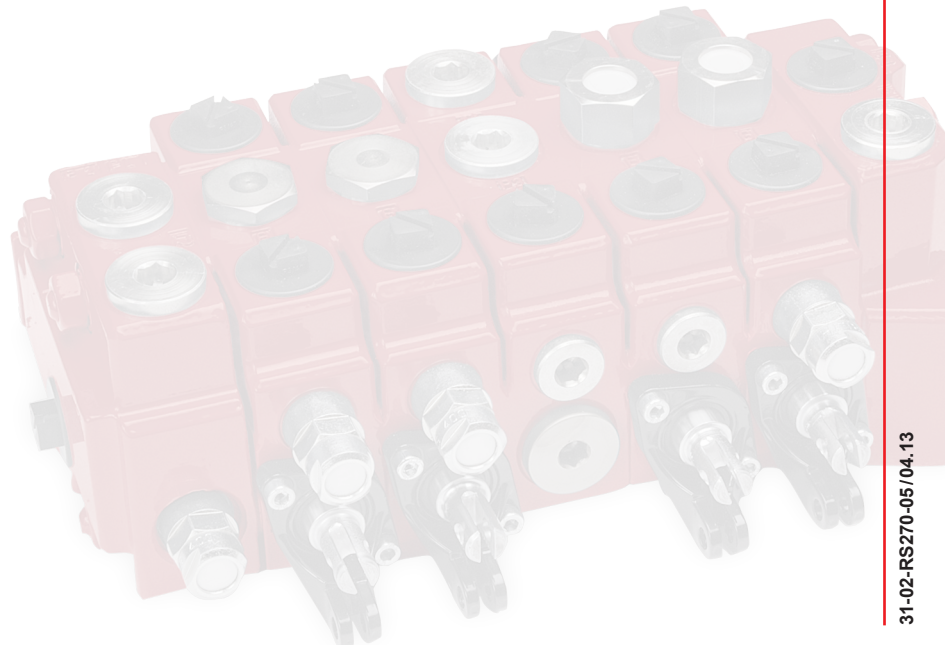

General overview

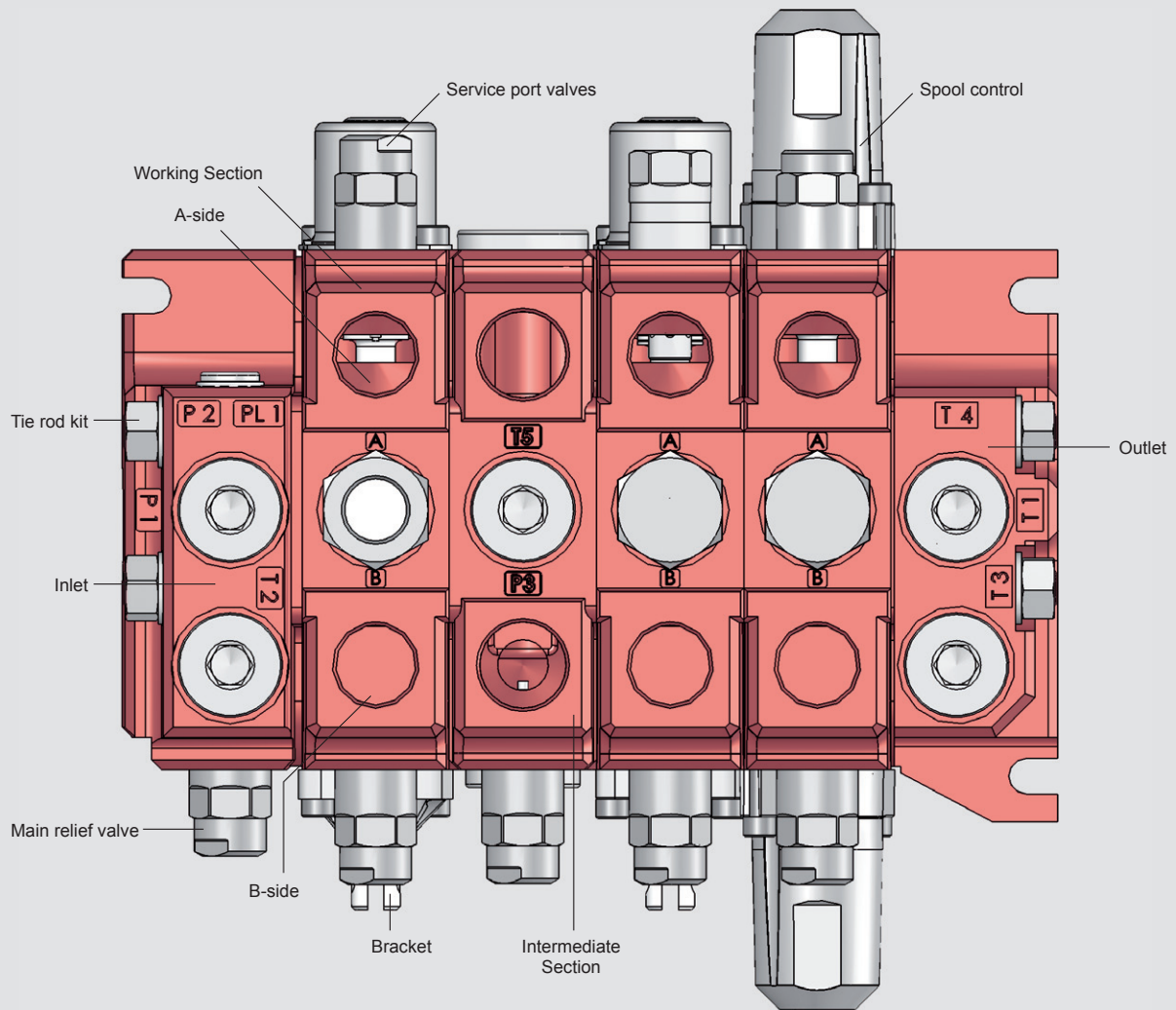

Pressure drop

Oil temperature / viscosity for all graphs: +40 °C / 32 cSt

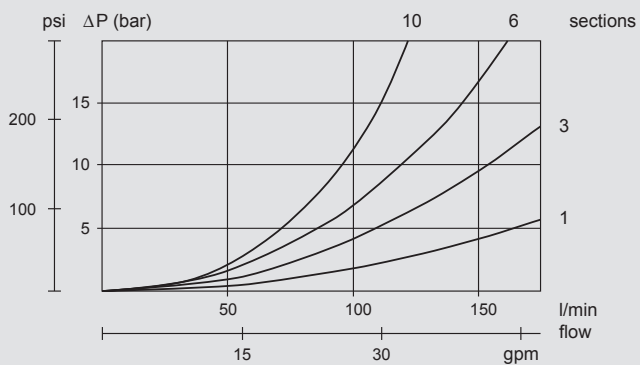

Pressure drop P - T

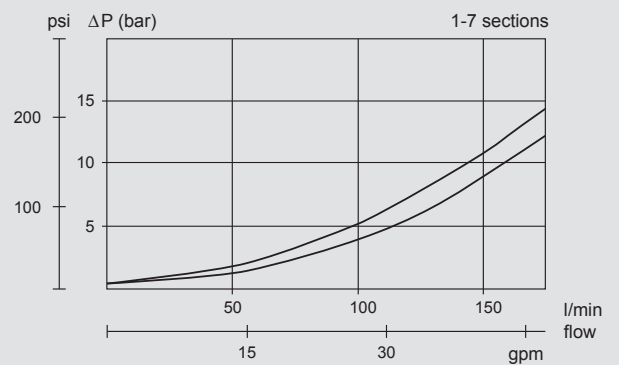

Pressure drop P - A/B

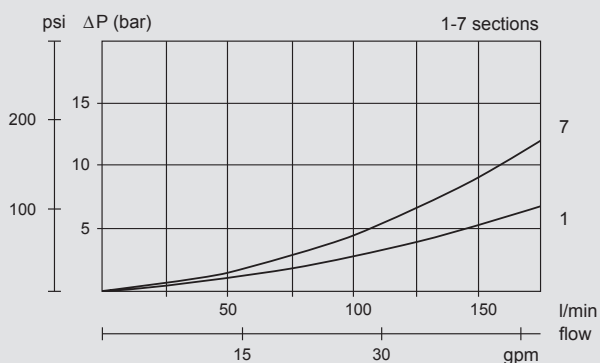

Pressure drop A/B - T

Dimensions and Weight

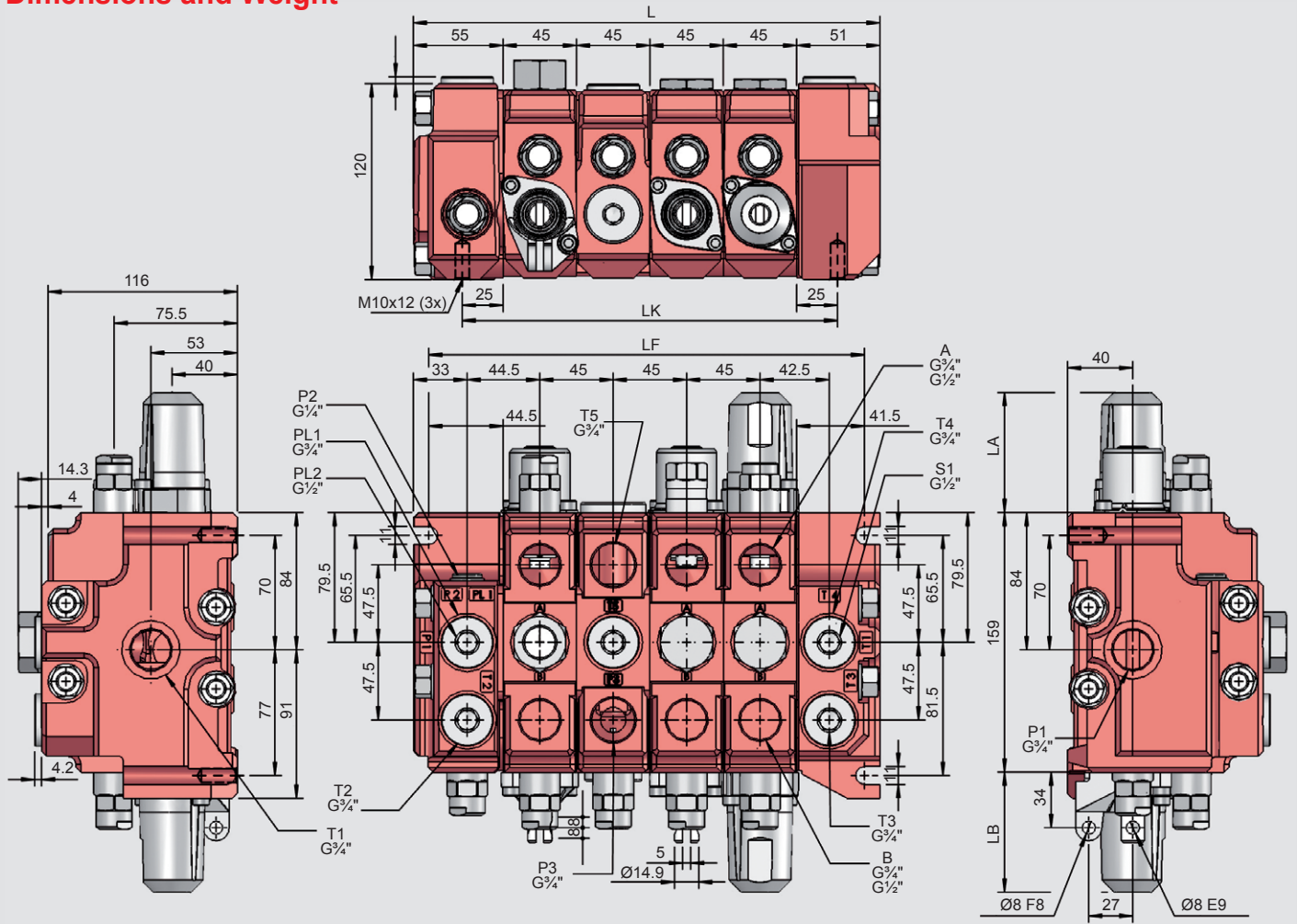

Weight

Inlet section	4.4 kg
Outlet section	4.2 kg
Working section	5.0 kg
Intermediate section	4.4 kg

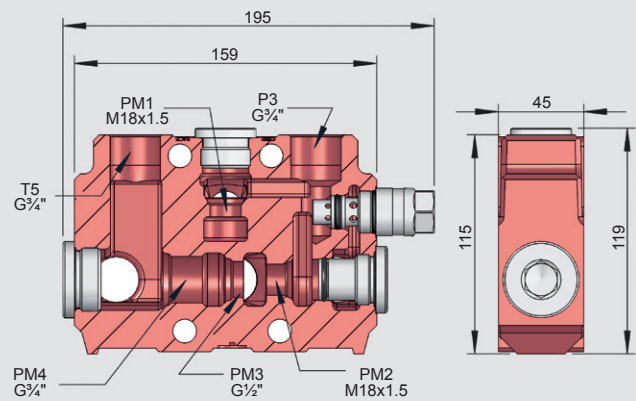

No. of sections	L [mm]	LF [mm]	LK [mm]
1	151	132	95
2	196	177	140
3	241	222	185
4	286	267	230
5	331	312	275
6	376	357	320
7	421	402	365
8	466	447	410
9	511	492	455
10	556	537	500

Type	LA [mm]	Type	LB [mm]
9	40.5	M1	42
10	87	M2	15
11	87	M3	52
13	87	3W	92
14	87	4W	102
L81-83	105	HPD1B	72
P	101		
EP	101		
HPD1A	72		
HPD405	107.5		

Main relief valves, service port valves

Main relief valve TBS400

TBS400 is a pilot operated relief valve for the inlet and intermediate sections. It is adjustable and sealable.

- Setting range:
35 – 350 bar
(3.5 – 35.0 MPa)
- Setting range step: 5 bar

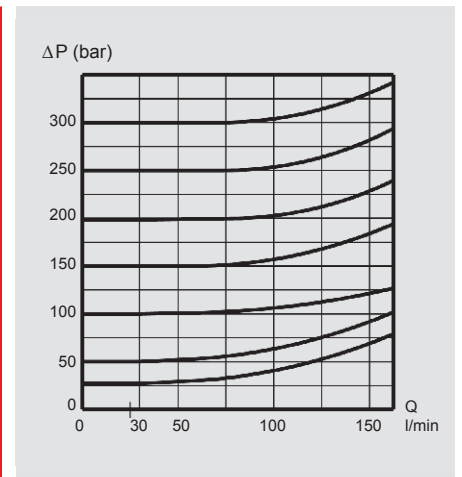
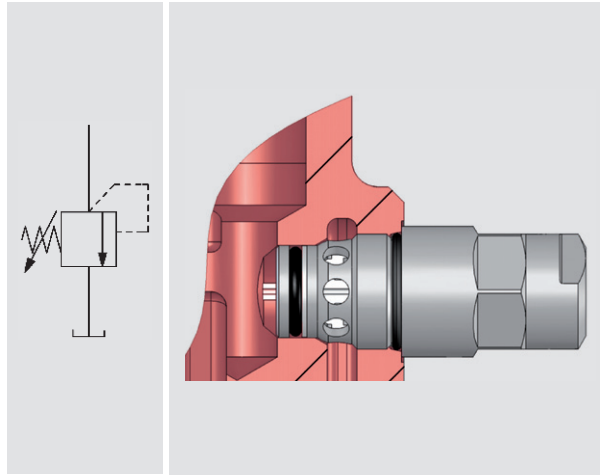

Port relief valve TBD160

TBD160 is a differential area, direct acting relief valve for the secondary circuit. TBD160 is adjustable and sealable.

- Setting range:
35 – 300 bar
(3.5 – 30.0 MPa)
- Setting range step: 5 bar

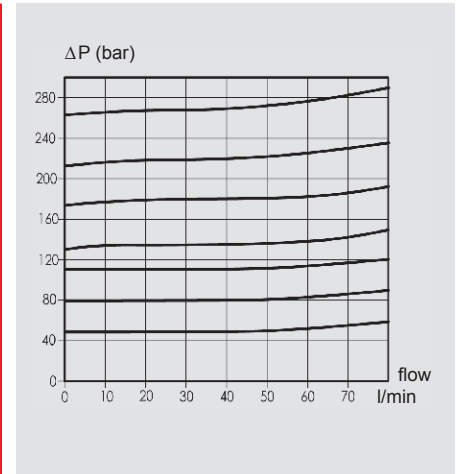
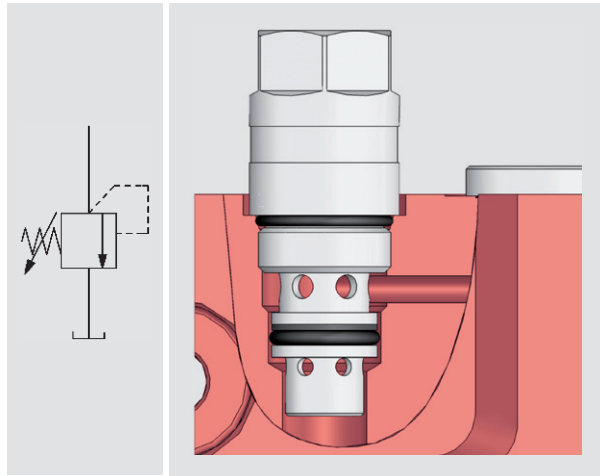

Anticavitation valve SB500

The anticavitation valve service to ensure that, in the event of a lower pressure in the cylinder port than in the tank, oil can be drawn from the system oil tank to the consumer.

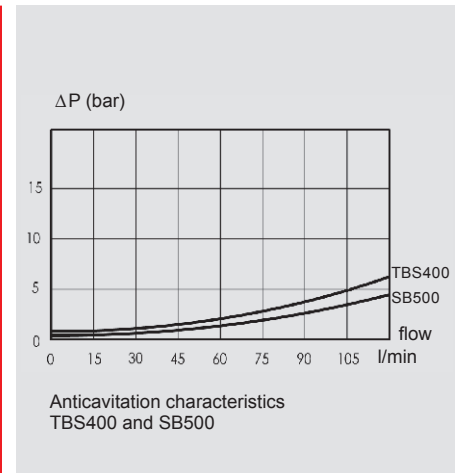
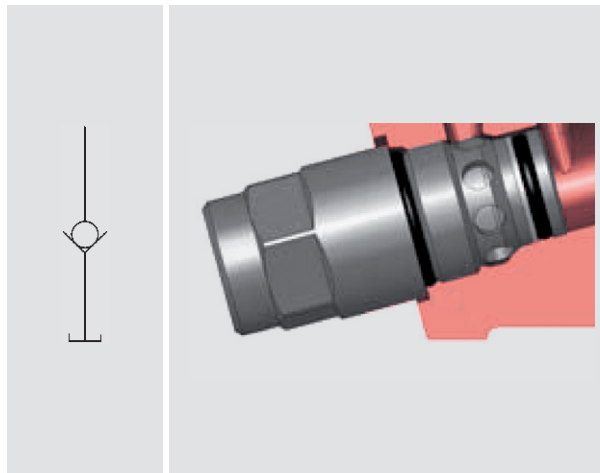

Spool controls – A-side

Spool control 9 910 Spring centered	
Spool control 10 Detents at positions 1, 2 and 3	
Spool control 11 Spring centering with detent at position 4	
Spool control 13 Spring centering with detent at position 2	
Spool control 14 Spring centering with detent at position 3	
Spool control P Pneumatic*	
Spool control EP Electro / pneumatic on / off**	
Spool control HPD1 Hydr. proportional Pilot pressure: 6 – 16 bar Max. pilot pressure: 25 bar***	
Spool control HPD405 Hydr. proportional spool control with float in 4th position***	
Spool control L81 External hydraulic kick-out from inserted spool***	
Spool control L82 External hydraulic kick-out from extended spool***	
Spool control L83 External hydraulic kick-out from inserted and extended spool***	

* Connection G 1/8" BSP





*** Connection G 1/4" BSP

** Power consumption	4.8 W
Rated voltage	24 V
Max voltage variation	+/- 10 %
Duty factor	100 %
Connection	according to EN175301-803/B
Protection class	IP65

Spool controls – B-side

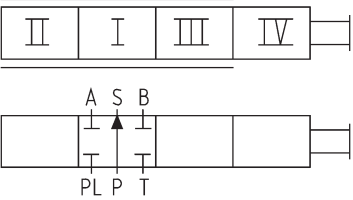
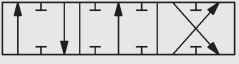
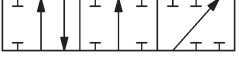
Bracket M1 Bracket for 3-position spool	3W Cap for 3-position spool controlled by cable
Bracket M2 Bracket for 3-position spool, without ear	4W Cap for 4-position spool controlled by cable
Bracket M3 Bracket for 4-position spool	

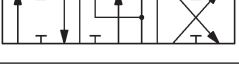
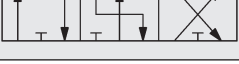
Spools

	<p>Spools for general use</p> <p>Function</p>	<p>Code</p>
	<p>Double acting spool</p>	<p>1X</p>
	<p>Single acting spool P – B</p>	<p>2X</p>
	<p>Double acting spool with 4th pos. for float</p>	<p>3X</p>
	<p>Motor spool</p>	<p>4X</p>
	<p>Motor spool A – T</p>	<p>4XA</p>
	<p>Motor spool B – T</p>	<p>4XB</p>
	<p>Regenerative spool</p>	<p>8XB</p>

The RS 270 spools are available in variety of flows and styles to accommodate most design requirements. Since the development of spools is a continuous process and all available spools are not described in this data sheet, contact Hydac for advice on choosing spools in order to optimize your valve configuration.

Generally the spools are divided in 6 different flow ranges. The letter indicating flow ranges is replaced by X. D = 60 l/min, F = 70 l/min, H = 80 l/min, G = 90 l/min, K = 120 l/min. In the table only the accessibility of different functions are shown.

High pressure carry-over

High pressure carry-over plug PS28

Plug PS28, mounted in S1 allows a high pressure carry-over function.

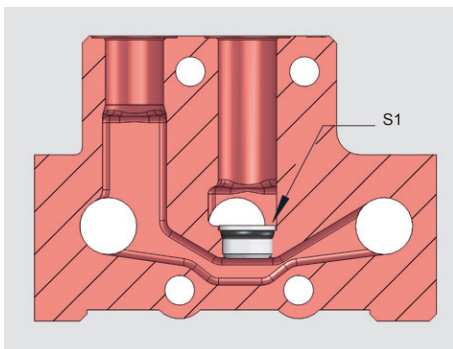

System alternatives with intermediate section

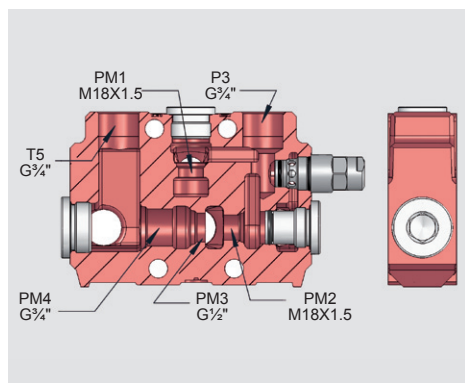

The intermediate section allows a number of different internal and external system alternatives.

Existing valve equipped with the intermediate section can easily be altered to other system configurations without dismantling the valve.

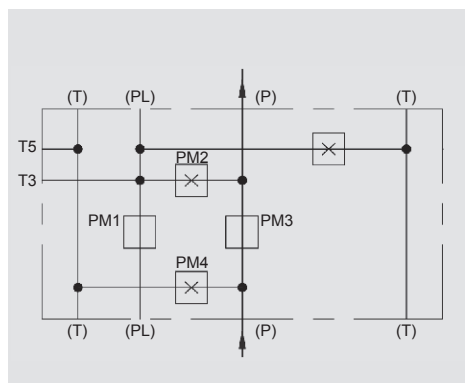

K1, Single circuit

Valve internally parallel coupled.

Main relief valve for the system can be positioned in the intermediate section.

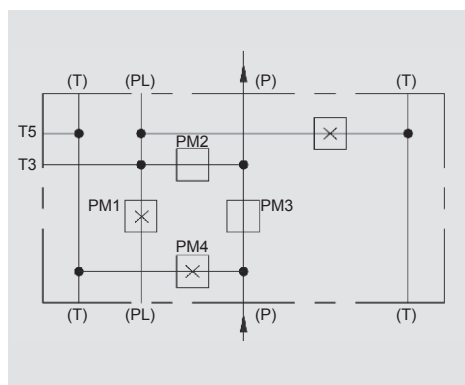

K2, Single circuit

Valve internally tandem coupled, i.e. working sections upstream of the intermediate section with fully selected spools have complete priority as far as flow supply is concerned in relation to working sections downstream of the intermediate section.

A second main relief valve, positioned in the intermediate section, can be used to reduce the pressure to working sections downstream from the intermediate section.

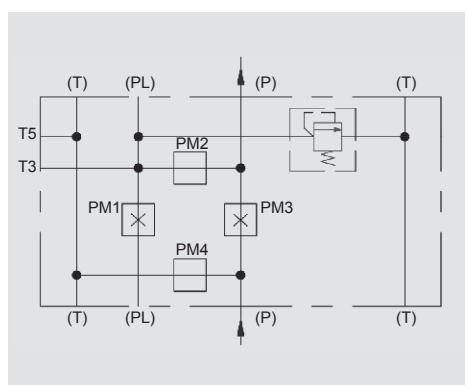

K3, Dual circuit

The intermediate section divides the valve into two completely separated circuits. The tank gallery is common.

Multicircuit operation is possible according to the same pattern.

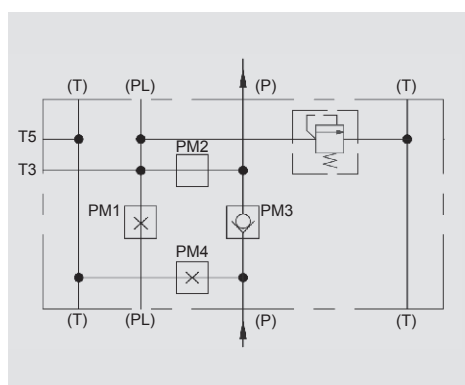

K5, Dual circuit

Tandem coupling between first and second circuit.

The first circuit is always solely supplied from the first pump.

The second circuit is always supplied from the second pump.

When the first circuit is inactive then the second circuit is supplied from both pumps.

Multicircuit operation is possible according to the same pattern.

Typical hydraulic circuit diagrams

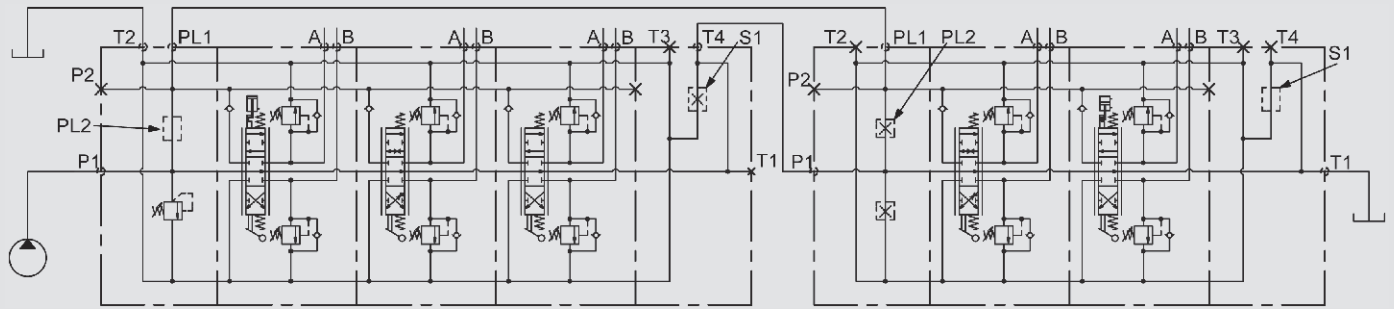

Diagram 1: High pressure carry-over

In parallel connection the same pump is connected to two or more valves.
The function is the same as if the pump was connected to one large valve.

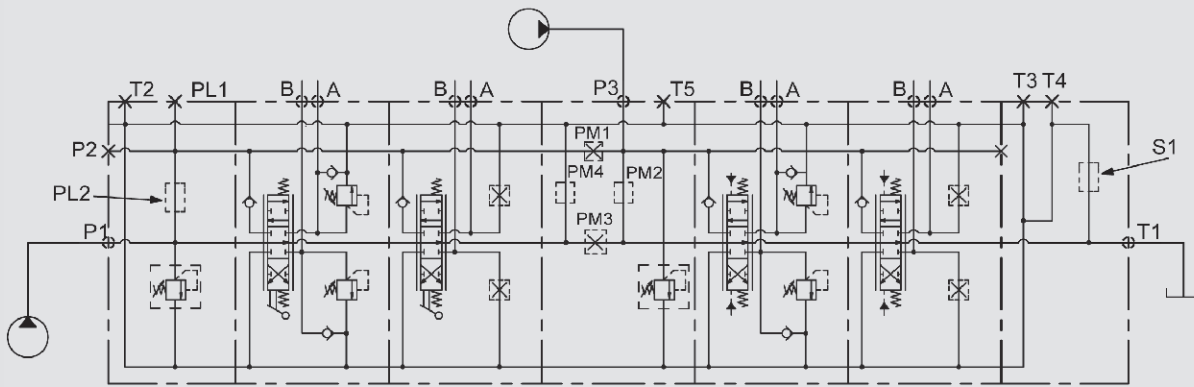

Diagram 2: Two pump circuit with intermediate section (K3)

Note

The information in this brochure relates to the operating conditions and applications described.
For applications or operating conditions not described, please contact the relevant technical department.
Subject to technical modifications.



Nordhydraulic
HYDAC INTERNATIONAL

Head Office
HYDAC INTERNATIONAL
GMBH

Industriegebiet
66380 Sulzbach/Saar
Germany

Phone: +49 6897 509-01
Fax: +49 6897 509-577

E-mail: mobilevalves@hydac.com
Internet: www.hydac.com