



## Hydraulic Pilot Controls CPVL Series

### Introduction

The product is supported by an extensive range of control curve characteristics and handles options, and can be supplied to control either two service or three service loader applications.

Our engineers can offer specialist support to optimise this product to suit your application. The product is supported by a comprehensive Sales and Service facility around the world.

### Benefits

- Compact and lightweight
- Optional linkage for lever connection
- Stylish good looks suitable for modern cabs
- Operator insulated from high temperature components
- Proven, simple pressure reducing elements
- Wide range of low hysteresis, high accuracy pressure control curves
- Wide range of electrical options in both standard and multi-functional ergonomic handles
- Electrically and mechanically releasable detents available as required
- Low effort lever control

### Functions

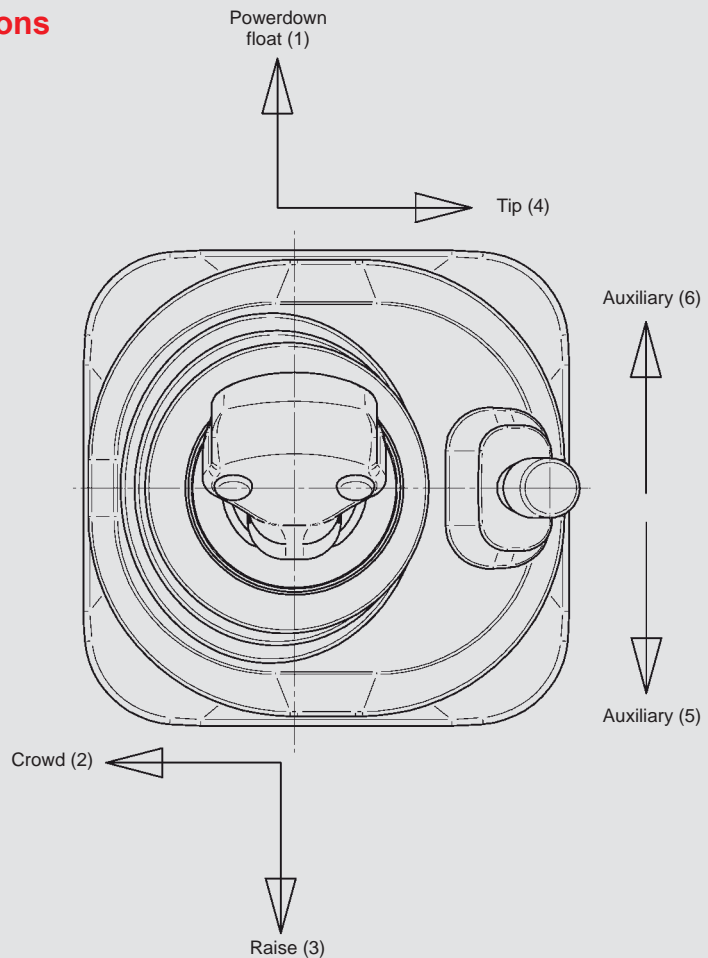

# Dimensions

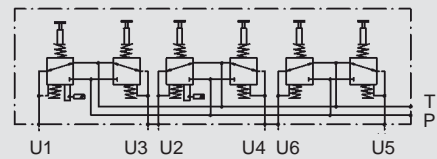
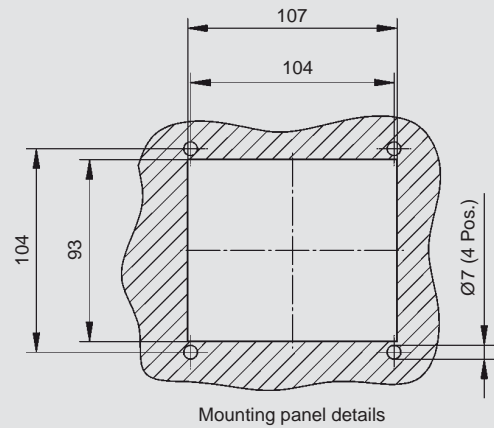
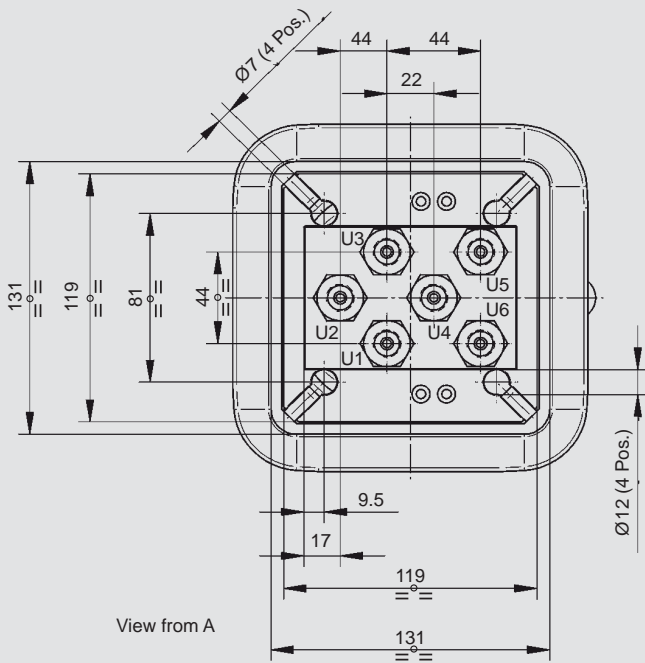
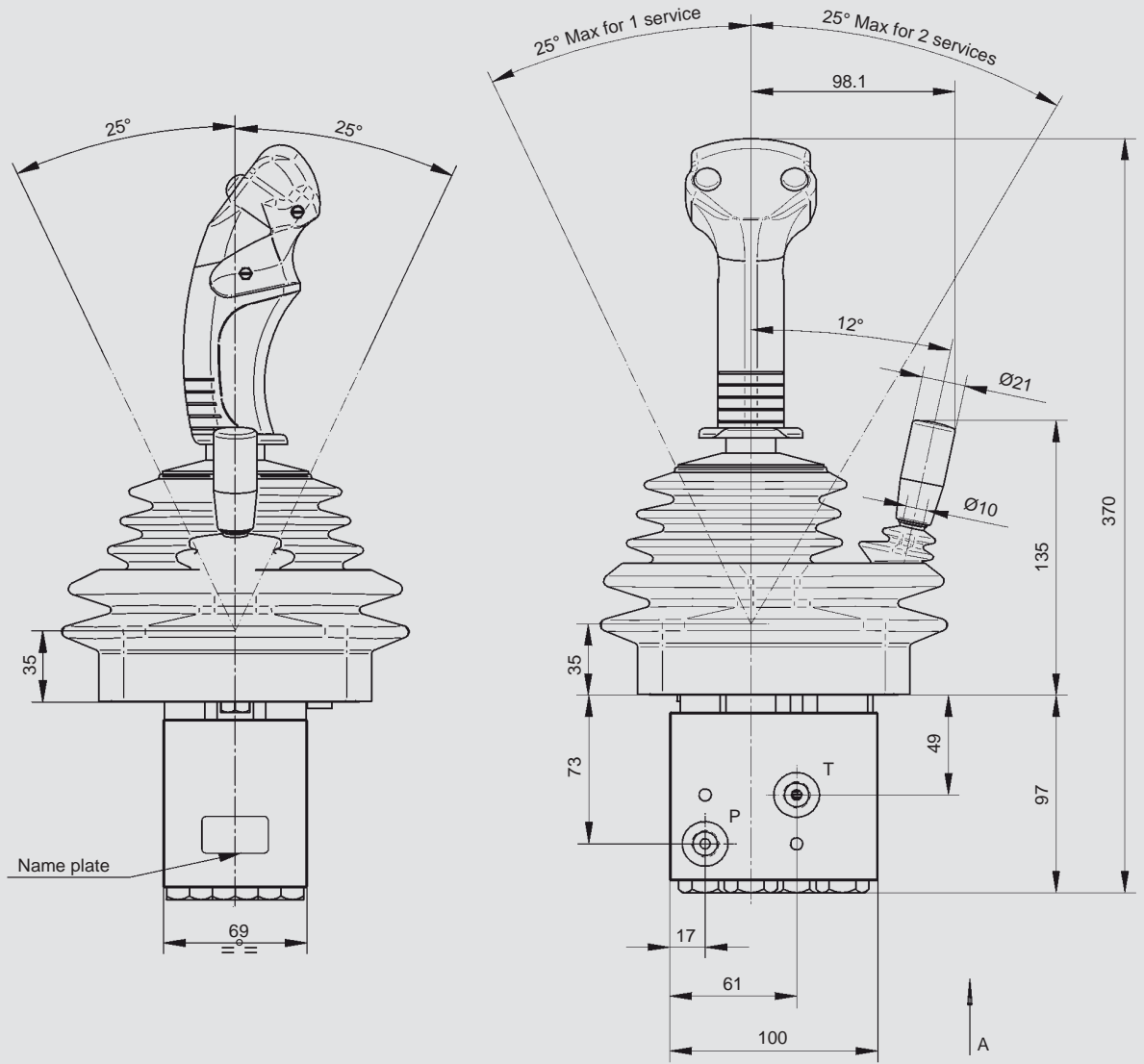

Circuit diagram

## Model code

**CPVL106** E 1 2 3 4 X X X X K 5 6 X X X X X

- W** = Without handle
- S** = Straight handle
- E** = Ergonomic handle

Metering curve no on port 1

Metering curve no on port 2

Metering curve no on port 3

Metering curve no on port 4

- E** = Electric detent on port 1
- M** = Mechanical detent on port 1
- X** = No detent

- E** = Electric detent on port 2
- M** = Mechanical detent on port 2
- X** = No detent

- E** = Electric detent on port 3
- M** = Mechanical detent on port 3
- X** = No detent

- E** = Electric detent on port 4
- M** = Mechanical detent on port 4
- X** = No detent

Knob type on auxiliary

Metering curve no on port 5

Metering curve no on port 6

- E** = Electric detent on port 5
- M** = Mechanical detent on port 5
- X** = No detent

- E** = Electric detent on port 6
- M** = Mechanical detent on port 6
- X** = No detent

- W** = Without linkage
- L** = With linkage

- 1** = 12 V DC Magnets
- 2** = 24 V DC Magnets

- B** = 1/4" BSP Ports (standard option)
- S** = 7/16"-20 UNF SAE Ports

## Note

The information in this brochure relates to the operating conditions and applications described.

For applications or operating conditions not described, please contact the relevant technical department.

Subject to technical modifications.



**Nordhydraulic**

HYDAC INTERNATIONAL

Head Office  
HYDAC INTERNATIONAL  
GMBH

Industriegebiet  
66380 Sulzbach/Saar  
Germany

Phone: +49 6897 509-01  
Fax: +49 6897 509-577

E-mail: [mobilevalves@hydac.com](mailto:mobilevalves@hydac.com)  
Internet: [www.hydac.com](http://www.hydac.com)