

**Solenoid Valves, 10 mm
for Explosion-Hazard Areas
Two-Stage Design, Series EEx-WEV ...**

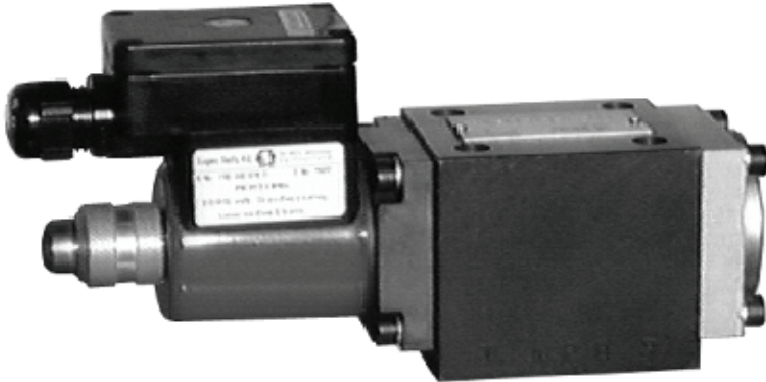

- 315 bar, 90 l/min
- High switching reliability thanks to two-stage follower spool design
- Protection class EEx em II T4 in accordance with EN 50014, 50019 and 50028
- Slip-on coil design, coils can be changed without opening hydraulic envelope
- With manual override
- Certificate of Conformity No. PTB 00 ATEX 2211 X
- With ISO 4401 / CETOP R35H size 5, NFPA D05, DIN 24 340 A10 interface

1. Description

Series EEx-WEV...-10 high performance spool valves are two-stage units which use the follower spool principle. The main valve components are a steel body, a spring-centered follower spool assembly and wet armature solenoids with pressure-tight core tube and a slip-on coil which is certified for use in explosion-hazard areas. The coil slips over the core tube and is retained by a knurled nut. The solenoid housing is made of aluminium with spray painted finish. The solenoid armature is of the oil-immersed type. The coil winding is

vacuum encapsulated and as a result has a high operational reliability. The coil terminal box is threaded PG 13,5 for a cable entry gland. Valves are supplied complete with cable entry gland but without cable. The valves provide reliable service even under the severest operating conditions such as high flow rates, high operating pressures, long periods without switching and large temperature fluctuations. The highly effective spool actuation method combines the advantages of both direct acting and two-stage sole-

noid valves, without incurring the well known disadvantages of either type. The main spool is offset by both the solenoid force and the P - T *) pressure difference inside the valve. The greater the P - T pressure difference, the greater the offsetting force. It is brought back to its deenergised position in the same way, using the P - T pressure difference and without the need for heavy centering springs. *) The pressure in P must exceed that in T and the valve must be connected in the conventional manner i.e. pressure to P, T to tank.

2. Symbols

4/2 FUNCTIONS	4/2 FUNCTIONS WITH 4/3 SPOOLS	4/2 FUNCTIONS WITH 4/3 SPOOLS	4/3 FUNCTIONS
EEx-WEV-42-A-10 1	EEx-WEV-42-AD-10 7	EEx-WEV-42-BD-10 13	EEx-WEV-43-D-10 19
EEx-WEV-42-B-10 2	EEx-WEV-42-AG-10 8	EEx-WEV-42-BG-10 14	EEx-WEV-43-G-10 20
 3	EEx-WEV-42-AH-10 9	EEx-WEV-42-BH-10 15	EEx-WEV-43-H-10 21
 4	 10	 16	 22
Crossover transients 5	 11	 17	For other spools please consult BUCHER 23

3. Main characteristics

Designation		4/2 and 4/3 solenoid controlled spool valves
Design		two-stage
Mounting method		manifold mounting
Size		nominal 10 mm, ISO 4401 size 5 interface
Weight	kg	with 1 solenoid: 3,9 / with 2 solenoids: 4,7
Mounting attitude		horizontal recommended (vertical mounting makes air bleeding difficult)
Flow direction		see symbols
Operating pressure range	bar	max. 315 in P, A and B / max. 15 in T
Flow rate, Q _{max}	l/min	90
Fluids		HL and HLP hydraulic oils to DIN 51 524; for other fluids, please consult BUCHER
Fluid temperature range	°C	-25 ... +80
Ambient temperature	°C	-25 ... +50
Viscosity range	mm ² /s (cSt)	10 ... 500, recommended 15 ... 250
Minimum fluid cleanliness level		18/14 to ISO 4406 / CETOP RP70H; 8 ... 9 to NAS 1638
Solenoid type		pressure-tight wet armature design
Nominal voltages	VAC VDC	115 / 230 50 ... 60 Hz 24
Nominal voltage tolerance	%	+ 10 / - 5
Nominal power consumption	W VA	Solenoid type 2 A 52: 24 VDC = 12 Solenoid type 2 C 52: 115 / 230 VAC = 15
Relative duty cycle	%	100
Max. core tube pressure (static)	bar	15
Enclosure protection		EEx em II T4 without cable
Protection type and design		IP 67 for coil, IP 65 for cable gland to EN 50014 / 50019 and 50028
Electrical connection		Valves (and solenoids) are supplied with a PG 13.5 cable gland but without cable. Suitable cable: min. ø 6 / max. ø 12, 3 x 1,5 mm ² . Coils must be protected by a fuse whose maximum permissible rating is three times the nominal coil current.

4. Performance graphs

Measured with oil viscosity 33 mm²/s (cSt) coil at steady-state temperature, 5% under-voltage

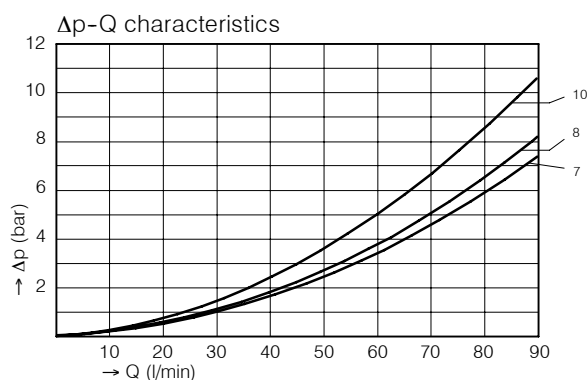
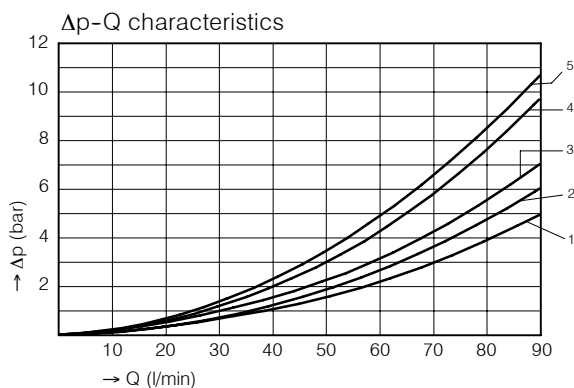

	energised				deenergised
	P ⇒ A	B ⇒ T	P ⇒ B	A ⇒ T	P + A+B ⇒ T
A spool	2	5	2	5	--
D spool	7	10	7	8	--
G spool	3	4	3	2	--
H spool	2	4	2	2	1

Switching times	Spool A, D, G	Spool H
Solenoid ON	100 ms	200 ms
Solenoid OFF	40 ms	40 ms

These are guideline values only, and can be significantly affected by flow rate, pressure and oil viscosity.

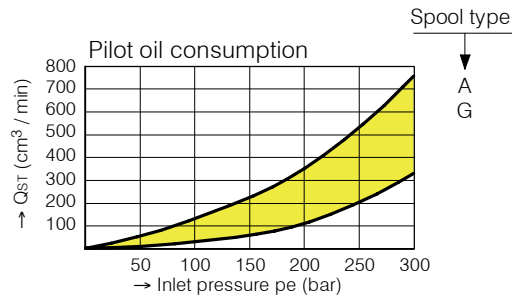
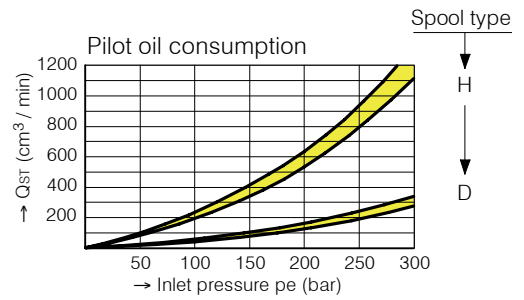

5. Dimensions

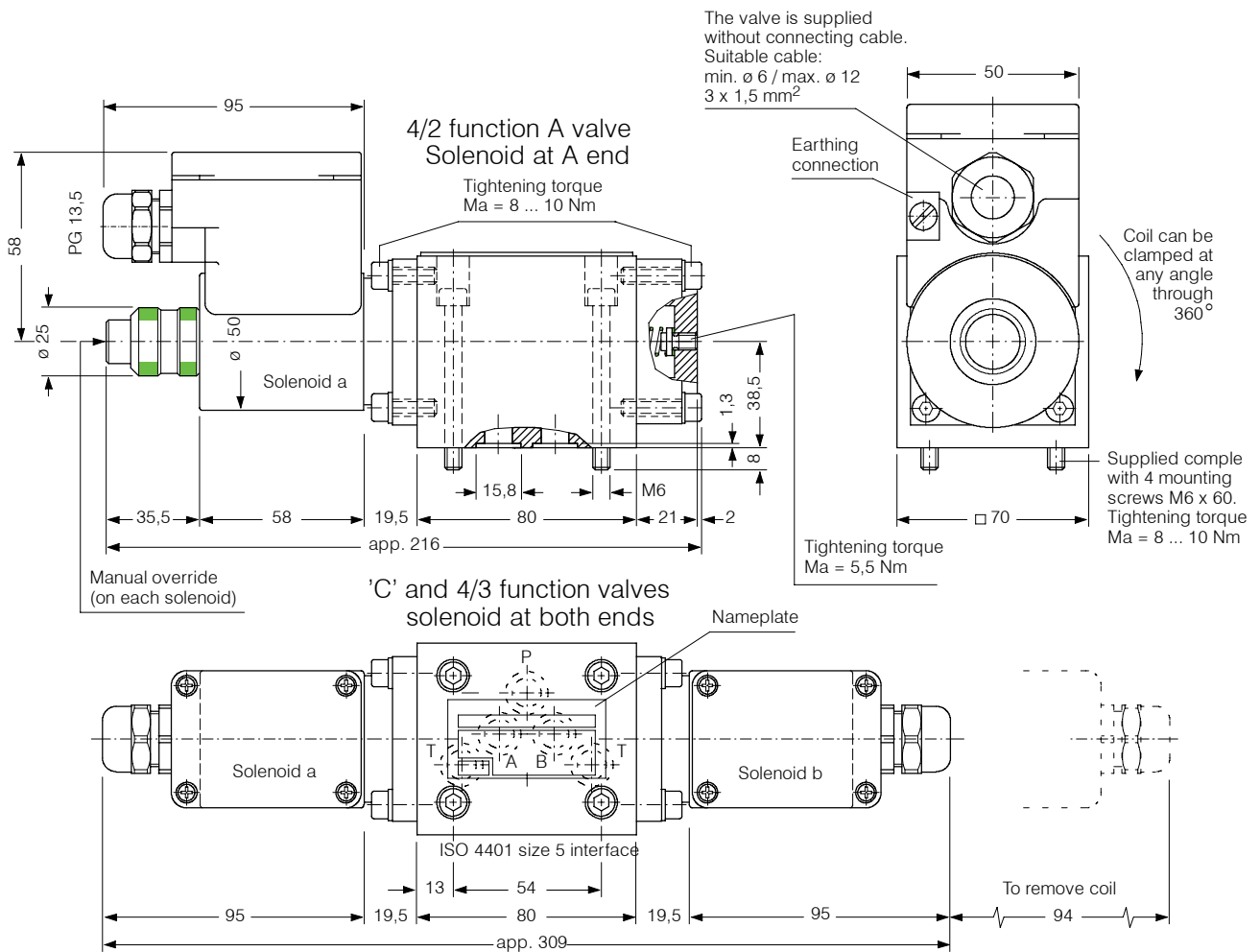

6. Schematic section

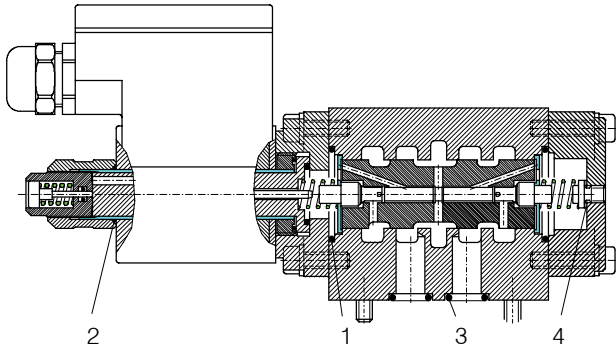

Seal kit no. DS-092, comprising *):

Itm.	Qty.	Qty.	Description	Size
1	2*)	2	O-ring no. 123	Ø 29,82 x 2,62 N90
2	2*)	1	O-ring no. 017	Ø 17,17 x 1,78 N90
3	5*)	5	O-ring no. 014	Ø 12,42 x 1,78 N90
4	-	1*)	Copper ring	Ø 6/10 x 1 DIN 7603 A

4/2 Valves (1 solenoid)
4/3 Valves (2 solenoids)

7. Installation and servicing

All installation and servicing must be carried out with care, and by qualified personnel only. When changing seals,

the new seals must be thoroughly oiled or greased before fitting them to the

valve. Use the correct tightening torques when fitting screws.

8. Ordering code

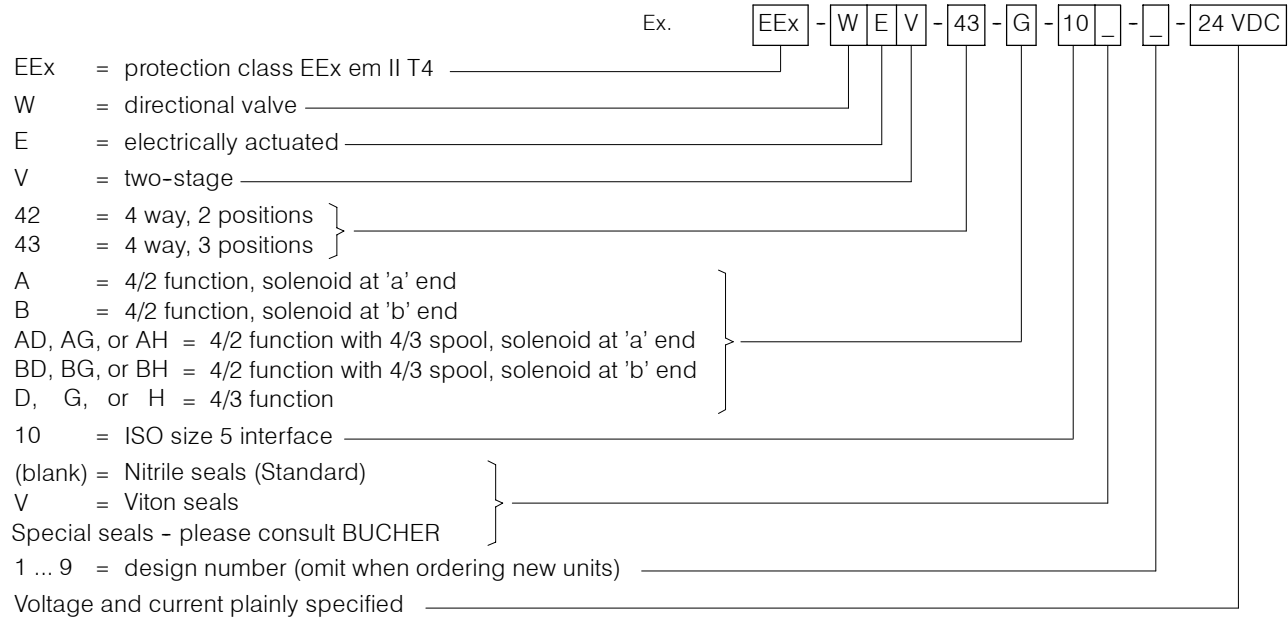

9. Related data sheets

Old no.	New no.	
i - 00	400-P-010101-E	Table of interface equivalents
i - 41	400-P-050101-E	DIN 24 340 size A10 interface
		Certificate of Conformity No. PTB 00 ATEX 2211 X for coil
W-01	400-P-12100-E	High Performance Spool Valves

info.ch@bucherhydraulics.com

www.bucherhydraulics.com

© 2015 by Bucher Hydraulics AG Frutigen, CH-3714 Frutigen

All rights reserved.

Data is provided for the purpose of product description only, and must not be construed as warranted characteristics in the legal sense. The information does not relieve users from the duty of conducting their own evaluations and tests. Because the products are subject to continual improvement, we reserve the right to amend the product specifications contained in this catalogue.