

Coils for Solenoid Valves

Wide variety of connector types, power ratings and voltages
Series D36...

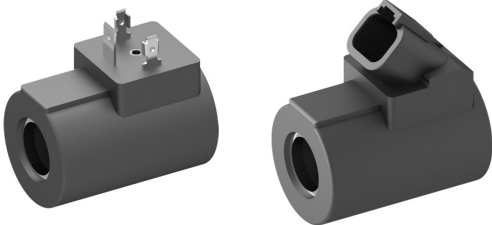

- Facilitates compact assemblies
- All common AC and DC voltages
- Power consumption 8 W, 17 W, 27/25 W
- Wide variety of connector types
- With optional protection diode
- Protection class IP 65 / IP 67 / IP 69K
- For core tube \varnothing 16 mm

1 Description

The slip-on coils can be replaced without opening the hydraulic envelope and can be positioned at any angle through 360°. When combined with the appropriate core tube, the coils produce an on/off solenoid function or a proportional solenoid function. Thanks to the wide variety of connector types and voltages, these coils are suitable for

widespread use in mobile and industrial applications. These coils are very adaptable in use, a benefit that is enhanced by various power ratings and an optional protection diode. The coil encapsulation and the plug base are glass-fibre reinforced thermoplastic.

2 Symbol

Connector type to DIN EN

Direct current DC

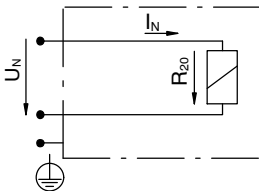

Alternating current AC

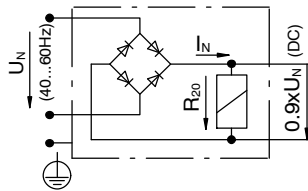

All connector types except DIN EN (DC)

Without protection diode

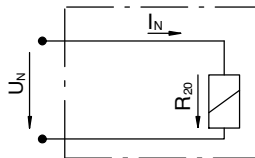

With bipolar protection diode

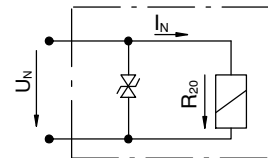

ATTENTION!

Protection of AC solenoid coils.

The rectifier built into the coil can be damaged by high voltage spikes.

To prevent AC coils from being destroyed, a mating connector with integral power varistor is recommended.

3 Technical data

General characteristics	Description, value, unit
Designation	Coil, D36
Design	slip-on, rotatable 360°
Mounting method	core tube, knurled nut
Ambient temperature range	-30 °C ... +60 °C
Coil weight	190 ... 230 g (dependent on type of connection)

Electrical characteristics	Description, value, unit		
Electrical connection	- DIN EN 175301-803, 3-pole 2 P+E - Deutsch plug connection DT04-2P - Junior Timer radial plug connection, 2-pole - Junior Timer axial plug connection, 2-pole - AMP Super Seal 1,5 / Metri-Pack 150, 2-pole - Kostal plug connection M27x1, 2-pole - flying leads, 2-pole		
Insulation class to VDE 0580	H (180 °C)		
Protection class to ISO 20 653 / EN 60 529	IP 65 / IP 67 / IP 69K, see "Ordering code" (with appropriate mating connector and proper fitting and sealing)		
Relative duty cycle	100 %		
Control current	See valve data sheet (proportional function)		
Supply voltage tolerance	± 10 %		
Overview of supply voltages / power ratings:	Nominal power consumption:		
12 V DC	8 W	17 W	27 W
24 V DC	8 W	17 W	27 W
26 V DC	-	-	27 W
28 V DC	-	17 W	27 W
200 V DC	-	-	25 W
115 V AC	-	17 VA	25 VA
230 V AC	-	17 VA	25 VA

Supply voltage: 12 V DC	8 W	17 W	27 W
Coil resistance R			
- cold value at + 20 °C	18.0 Ω	8.6 Ω	5.8 Ω
- cold value at - 30 °C	14.5 Ω	6.9 Ω	4.7 Ω
- max. warm value	28.2 Ω	13.5 Ω	9.1 Ω
Inductance	37 mH	17 mH	10 mH
Measured at the core tube, non-operated, at 0.1 mA (rms) / 1 kHz			
Breakdown voltage for protection diode	33 V	33 V	33 V

Supply voltage: 24 V DC	8 W	17 W	27 W
Coil resistance R			
- cold value at + 20 °C	72.0 Ω	34.9 Ω	20.9 Ω
- cold value at - 30 °C	58.0 Ω	28.1 Ω	16.8 Ω
- max. warm value	112.7 Ω	54.6 Ω	32.7 Ω
Inductance	130 mH	68 mH	37 mH
Measured at the core tube, non-operated, at 0.1 mA (rms) / 1 kHz			
Breakdown voltage for protection diode	56 V	56 V	56 V

Supply voltage: 26 V DC	8 W	17 W	27 W
Coil resistance R			
- cold value at + 20 °C	-	-	25.0 Ω
- cold value at - 30 °C	-	-	20.1 Ω
- max. warm value	-	-	39.1 Ω
Inductance	-	-	49 mH
Measured at the core tube, non-operated, at 0.1 mA (rms) / 1 kHz			
Breakdown voltage for protection diode	-	-	56 V

Supply voltage: 28 V DC	8 W	17 W	27 W
Coil resistance R			
- cold value at + 20 °C	-	45.0 Ω	28.0 Ω
- cold value at - 30 °C	-	36.2 Ω	22.5 Ω
- max. warm value	-	70.4 Ω	43.8 Ω
Inductance	-	95 mH	60 mH
Measured at the core tube, non-operated, at 0.1 mA (rms) / 1 kHz			
Breakdown voltage for protection diode	-	56 V	56 V

Supply voltage: 200 V DC		8 W	17 W	25 W
Coil resistance R	- cold value at + 20 °C	-	-	1710 Ω
	- cold value at - 30 °C	-	-	1377 Ω
	- max. warm value	-	-	2677 Ω
Inductance		-	-	17'000 mH
Measured at the core tube, non-operated, at 120 Hz / 0.5 Vrms				
Supply voltage: 115 V AC		8 VA	17 VA	25 VA
Coil resistance R	- cold value at + 20 °C	-	630 Ω	430 Ω
	- cold value at - 30 °C	-	507 Ω	346 Ω
	- max. warm value	-	986 Ω	673 Ω
Supply voltage: 230 V AC		8 VA	17 VA	25 VA
Coil resistance R	- cold value at + 20 °C	-	2520 Ω	1710 Ω
	- cold value at - 30 °C	-	2029 Ω	1377 Ω
	- max. warm value	-	3945 Ω	2677 Ω

4 Dimensions

Coil with DIN EN plug connection

- Standard-Type (see Ordering code)

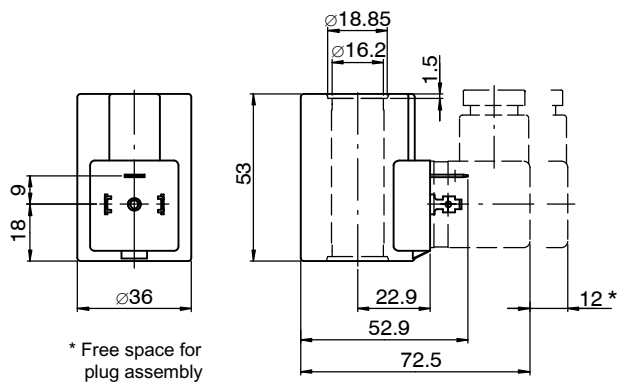

Coil with Deutsch DT04-2P plug connection

- Type D without quenching diode
- Type DT with quenching diode (see Ordering code)

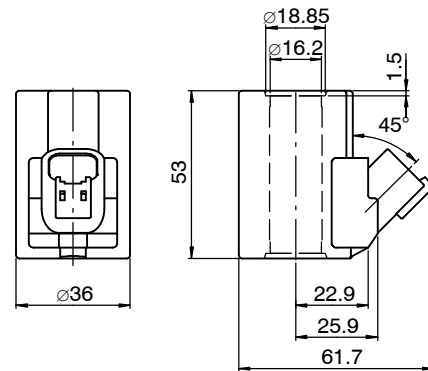

Coil with Junior Timer radial plug connection

- Type JT (see ordering code)

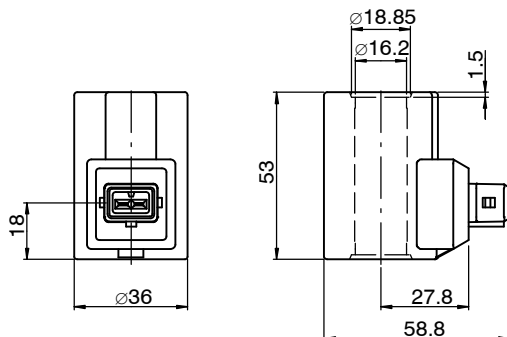

Coil with Junior Timer axial plug connection

- Type IT (see ordering code)

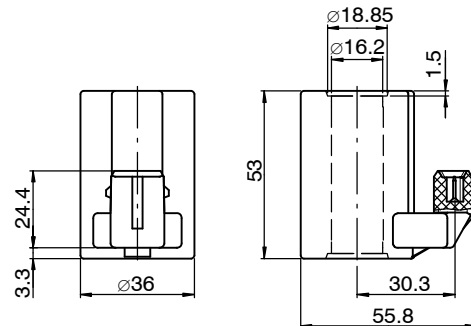

Coil with Kostal plug connection

- Type C (see ordering code)

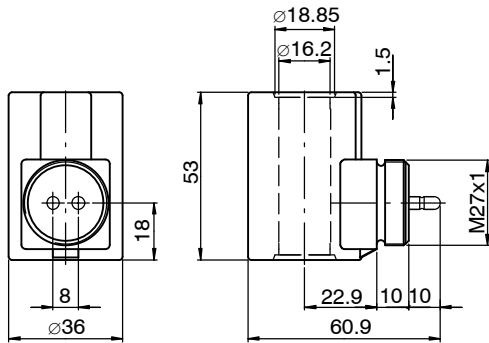

Coil with flying leads

- Type F (see ordering code)

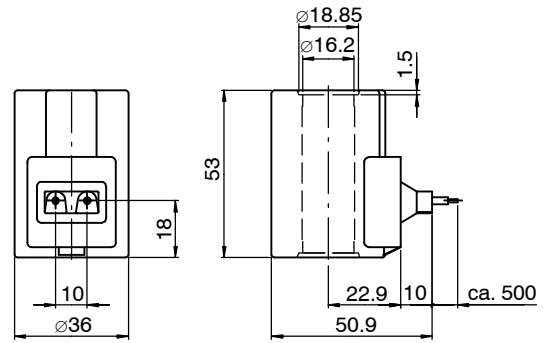

Coil with connection AMP Superseal / Metri Pack 150, 2-pole

- Type S (see ordering code)

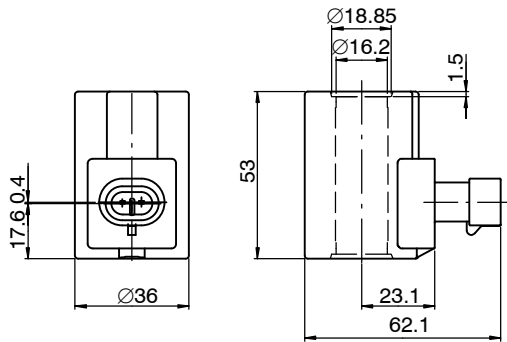

5 Installation information



Attention.

Because of the danger of overheating, the coil must only be operated when it is properly fitted on a valve. To prevent the ingress of water, both ends of the coil on the core tube must be properly sealed with O-rings.



Attention.

To obtain the maximum performance, be sure to fit the coil the right way round i.e. with plug base up (furthest from valve), or down (closest to valve). The data sheet for each solenoid cartridge valve shows the correct position for that valve.

6 Ordering code

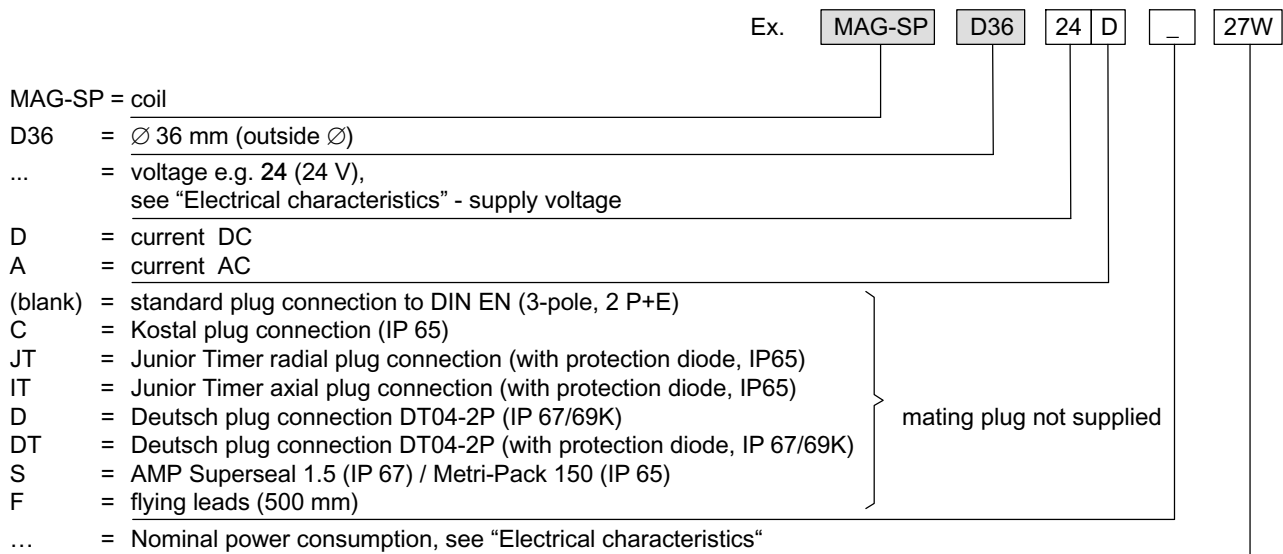

info.ch@bucherhydraulics.com

www.bucherhydraulics.com

© 2015 by Bucher Hydraulics AG Frutigen, CH-3714 Frutigen

All rights reserved.

Data is provided for the purpose of product description only, and must not be construed as warranted characteristics in the legal sense. The information does not relieve users from the duty of conducting their own evaluations and tests. Because the products are subject to continual improvement, we reserve the right to amend the product specifications contained in this catalogue.

Classification: 430.395...