

Preload Check Valves, Size 04 ... 40
Spherical Poppet-type, Screw-in Design
Series RVVE-...-... 360 l/min, 350 bar (500 bar)

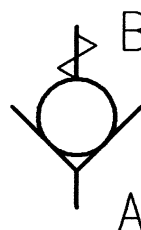

1 General

1.1 Product description

Series RVVE units are screw-in preload check valves with mounting threads ranging from G 1/8" to G 1½". For other thread forms, consult Bucher Hydraulics.

The valves prevent flow in the screw-in direction (B → A). In the opposite direction, there is a range of opening pressures from 4.0 ... 12.0 bar. For opening pressures lower than 4 bar, the RKVE-... model is available (see data sheet 170-P-051000-E).

The units are spring-closed spherical poppet valves with hardened body, poppet and seat. The properties of the poppet sealing surface have been enhanced by mechanical processing.

An external O-ring seals the leakage path between the valve and cavity wall. Please note that the two types of cavity use a different size of O-ring.

The valves can be used for pressure relief in the opening direction, but only to a limited extent (consult Bucher Hydraulics for such applications).

1.2 Advantages

- High pressure rating
- Compact construction
- High opening pressures
- Very small pressure rise

2 Main characteristics

Designation	preload check valve
Design	spherical poppet design
Mounting method	screw-in cartridge
Size	nominal 4...40 mm. See Table, "Dimensions"
Dimensions	see table "Dimensions"
Mounting attitude	unrestricted
No-flow direction	B → A (see symbol)
Operating pressure range	... 350 bar (for 500 bar, consult Bucher Hydraulics)
Opening pressure	4.0 ... 12 bar (for higher opening pressures, consult Bucher Hydraulics)
Flow rate, Q max.	... 360 l/min
Hydraulic fluid	HL and HLP hydraulic oils to DIN 51524
Temperature range	-30 ... +80 °C
Viscosity range	10 ... 500 mm ² /s (cSt)
Minimum fluid cleanliness	18/14 to ISO 4408 / CETOP RP70H; 8...9 to NAS 1638

For applications outside these parameters, please consult Bucher Hydraulics.

3 Schematic section

Sizes 04-25

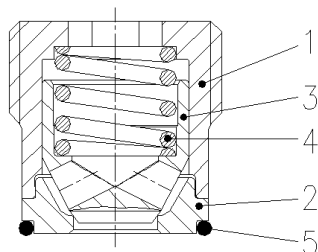

4 Components

It.	Qty.	Description
1	1	Valve body
2	1	Valve seat
3	1	Valve poppet
4	1	Spring
5	1	O-ring

5 Dimensions

5.1 Valve

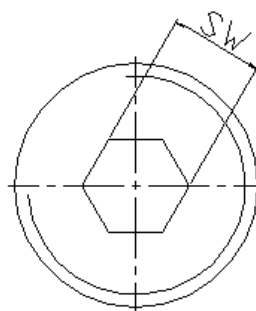
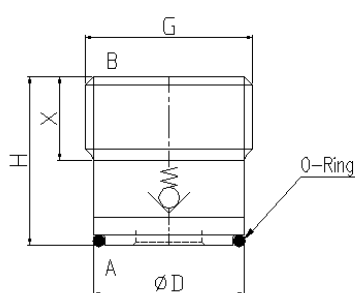

Sizes 04 ... 25

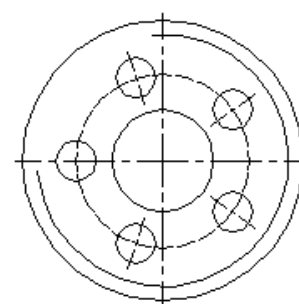

Sizes 32 and 40

	Q Nom = Qmax (l/min)					O-ring for cavity type REG-03	O-ring for cavity type REG-04	Tightening torque (Nm)	Fitting tool type
	G	ØD	H	X					
RVVE-04-...	8	G1/8"	8.50	15.00	7.50	6.2x1.0	6.0x0.8	3	4 A/F
RVVE-06-...	15	G1/4"	11.50	17.50	7.50	8.5x1.5	8.0x1.25	7	5 A/F
RVVE-08-...	30	G3/8"	14.90	20.00	9.50	12.0x1.5	12.0x1.0	15	6 A/F
RVVE-10-...	50	G1/2"	18.70	21.00	12.50	16.0x1.5	16.0x1.0	30	8 A/F
RVVE-16-...	80	G3/4"	24.20	26.00	12.00	20.0x2.0	20.0x1.5	60	10 A/F
RVVE-25-...	140	G1"	30.20	34.00	15.00	25.0x2.5	-	120	17 A/F
RVVE-32-...	240	G1¼"	39.10	62.00	24.00	34.0x2.5	-	200	MKS-32
RVVE-40-...	360	G1½"	44.50	76.00	30.00	40.0x2.5	-	300	MKS-40

5.2 Cavity type

5.2.1 Cavity type REG-03

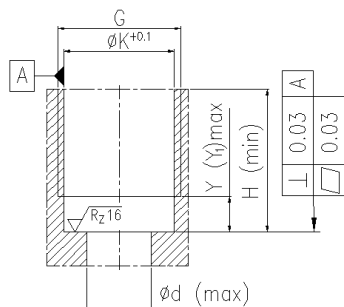

	G	ØK	Ød	Y ¹⁾	Y ₁ ²⁾	H
RVVE-04-...	G1/8"	8.70	4.0	7.5	4.0	15.0
RVVE-06-...	G1/4"	11.75	6.0	10.0	5.0	17.5
RVVE-08-...	G3/8"	15.25	8.0	10.5	5.0	20.0
RVVE-10-...	G1/2"	19.00	11.0	11.5	6.0	21.0
RVVE-16-...	G3/4"	24.50	15.0	14.0	7.0	26.0
RVVE-25-...	G1"	30.50	20.0	18.0	10.0	34.0
RVVE-32-...	G1¼"	39.50	26.0	38.0	12.0	62.0
RVVE-40-...	G1½"	45.00	33.0	46.0	12.0	76.0

¹⁾ Y is different from cavity type REG-01; valves can **not** be interchanged with types RVE-... / RKVE-...

²⁾ Y₁ is the same as cavity type REG-01; valves can be interchanged with types RVE-... / RKVE-...

5.2.2 Cavity type REG-04

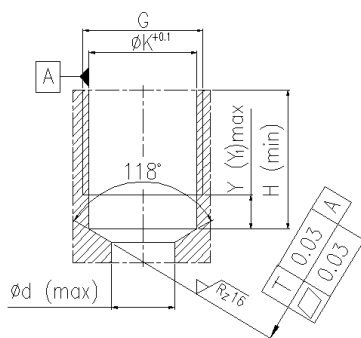

	G	ØK	Ød	Y ¹⁾	Y ₁ ²⁾	H
RVVE-04-...	G1/8"	8.70	4.0	6.0	2.5	15.0
RVVE-06-...	G1/4"	11.75	6.0	8.0	3.0	17.5
RVVE-08-...	G3/8"	15.25	8.0	9.0	3.5	20.0
RVVE-10-...	G1/2"	19.00	11.0	9.5	4.0	21.0
RVVE-16-...	G3/4"	24.50	15.0	12.0	5.0	26.0

¹⁾ Y is different from cavity type REG-02; valves can **not** be interchanged with types RVE-... / RKVE-...

²⁾ Y₁ is the same as cavity type REG-02; valves can be interchanged with types RVE-... / RKVE-...

6 Performance graphs

measured with oil viscosity 33 mm²/s (cSt)

RVVE-10-...

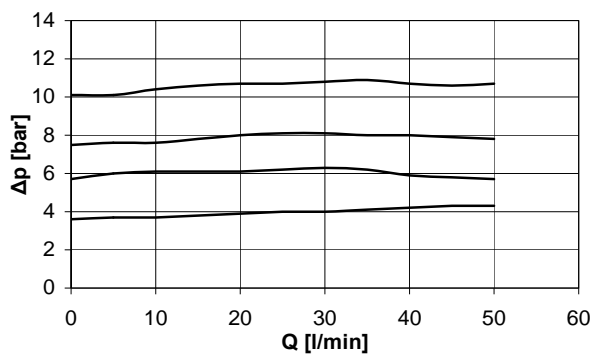

RVVE-16-...

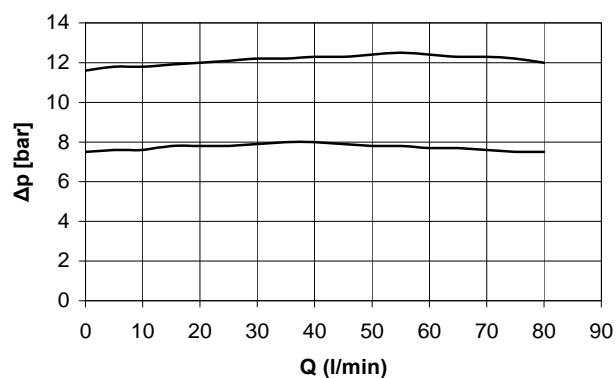

RVVE-25-...

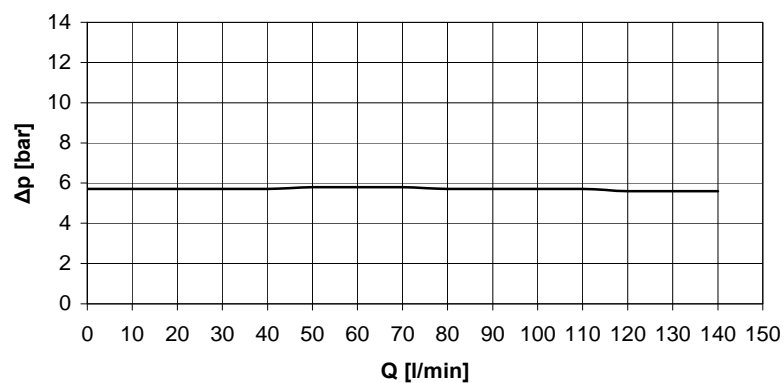

RVVE-40-...

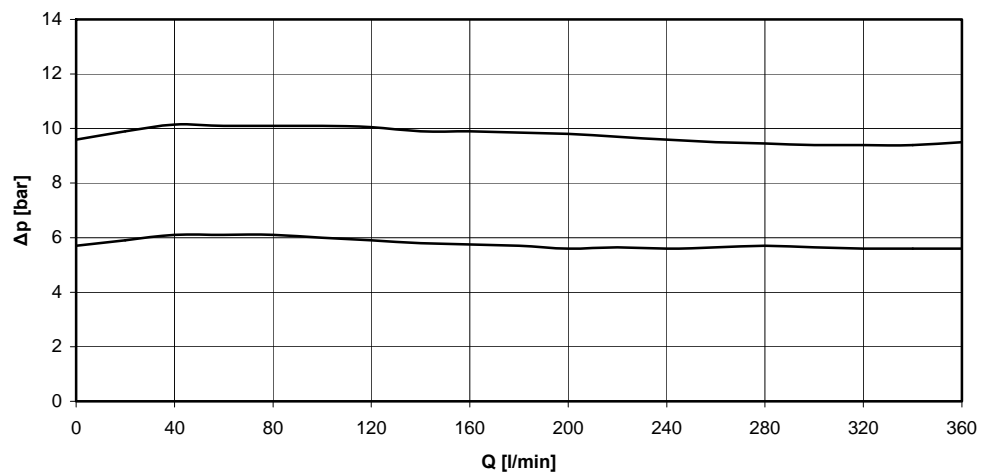

7 Ordering code

Model code



Preload check valve, screw-in

Thread

- Whitworth pipe thread G
- Metrical thread M
- UNF thread U

Nominal size

- 04
- 06
- 08
- 10
- 16
- 25
- 32
- 40

Opening pressure

- 4 bar
- 6 bar
- 8 bar
- 10 bar
- 12 bar

- 4
- 6
- 8
- 10
- 12

O-ring

- Nitrile (blank)
- Viton V
- Installation cavity REG-03
- Installation cavity REG-04

- (blank)
- OR118

Consult Bucher Hydraulics for further advice on:

- other opening pressures
- special materials
- customised designs

8 Design and installation notes

Be sure to keep to the installation dimensions and tolerances.

We offer form tools for hire or sale.

Do not situate nozzles and orifices directly before the check valve (referring to the free-flow direction) (see Data Sheet 170-P-059000-E).

When fitting the valve, take particular care to ensure that:

- the valve is firmly seated on the sealing surface, but that
- valve components are not deformed by the use of excessive force.

Recommendation: before installing the valve, fit the O-ring in the cavity.

Use the specified tightening torque when fitting the valve.

Special fitting tools (pin spanners) are available for sizes 32 and 40.

9 Application notes

Do not exceed the maximum operating pressure, and take any pressure peaks into consideration.

Do not exceed the specified nominal flow rate.

In applications such as accumulator circuits, where sudden pressure can be applied to the valve in the free-flow direction, ensure that the specified flow ratings are not exceeded.

Buyers bear the sole responsibility for ensuring that the selected products are suitable for their applications. Buyers ultimately establish this by undertaking qualification programs on test stands, or by evaluating the performance of prototype machines or systems.

10 Pin spanners for sizes 32 and 40

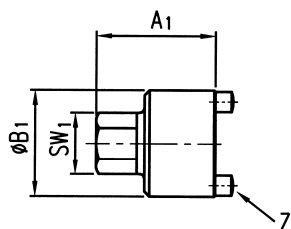

	A	A ₁	ØB	ØB ₁	A/F	SW ₁ (= A/F ₁)	Z
MKS32	-	45	-	38	-	19	5
MKS40	-	47	-	43	-	22	5

info.dah@bucherhydraulics.com

www.bucherhydraulics.com

© 2015 by Bucher Hydraulics Dachau GmbH, D-85221 Dachau

All rights reserved.

Data is provided for the purpose of product description only, and must not be construed as warranted characteristics in the legal sense. The information does not relieve users from the duty of conducting their own evaluations and tests. Because the products are subject to continual improvement, we reserve the right to amend the product specifications contained in this catalogue.