

3-Way Pressure-Reducing Valve, ISO Size 03

$Q_{\max} = 60 \text{ l/min}$, $p_{\max} = 315 \text{ bar}$

Sandwich design, with manual adjustment, direct acting

Series SDDRA-7...

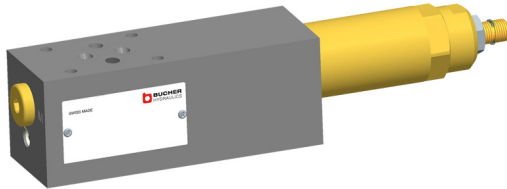

- With cartridge valve, type DDRA-7L...-10...
- Interface to ISO 4401-03-02
- Full-flow secondary pressure relief
- Function in the P or A line
- 5 pressure ranges available
- With pressure-gauge port
- Excellent stability over the whole pressure and flow range
- External cartridge parts are zinc plated and chromited (CrVI-free)
- Sandwich body is zinc-phosphated

1 Description

Series SDDRA-7...-6... sandwich valves are high performance, manually adjusted 3-way pressure-reducing valves with a size 03 interface to ISO 4401-03-02. The main components of the valves are a sandwich body (stack-mounting body) and the screw-in cartridge (type DDRA-7L...-10...). The pressure-reducing cartridges are direct acting and designed on the sliding-spool principle. Two models are available, one with the function in P and the other with the function A and an integral bypass check valve. These valves reduce the pressure in the secondary side of P or A (for flow IN) respectively to the value set at the pressure adjustment. The 3-way pressure-reducing cartridges function as full-

flow pressure-relief valves from port P → T or A → T respectively as soon as the reduced pressure rises above the valve pressure setting. A pressure-gauge port M (G1/4") is also provided in the secondary circuit. These sandwich valves are used to reduce the system pressure in mobile and industrial applications. The sandwich body is zinc-phosphated. All external parts of the cartridge are zinc-nickel plated to DIN 50 979 and are thus suitable for use in the harshest operating environments. The sandwich body is sealed at its manifold side (the connections side) by means of O-rings fitted in counterbores.

2 Technical data

General characteristics	Description, value, unit
Designation	3-way pressure-reducing valve
Design	sandwich design, with manual adjustment, direct acting
Mounting method	4 x \varnothing 5.4 holes for M5 cap screws
Size	size 03 interface to ISO 4401-03-02 / DIN 24 340 A6
Weight	2.5...2.9 kg
Mounting attitude	unrestricted
Ambient temperature range	-25 °C ... +80 °C

Hydraulic characteristics	Description, value, unit
Maximum operating pressure	315 bar
Flow range	...60 l/min
Nominal pressure ranges	...30 bar, ...60 bar, ...100 bar, ...160 bar, ...250 bar
Flow direction	see symbols

Hydraulic characteristics	Description, value, unit
Hydraulic fluid	HL and HLP mineral oil to DIN 51 524; for other fluids, please contact BUCHER
Hydraulic fluid temperature range	-25 °C ... +80 °C
Viscosity range	10...650 mm ² /s (cSt), recommended 15...250 mm ² /s (cSt)
Minimum fluid cleanliness Cleanliness class to ISO 4406 : 1999	class 20/18/15

3 Symbol

Function in P,
with external pilot-oil drain through Y

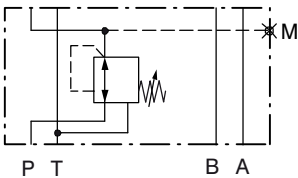

SDDRA-7...-P-6...

Function in A (for flow IN),
with external pilot-oil drain through Y

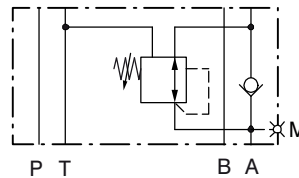

SDDRA-7...-AZR-6...

4 Dimensions & sectional view

4.1 Function in P

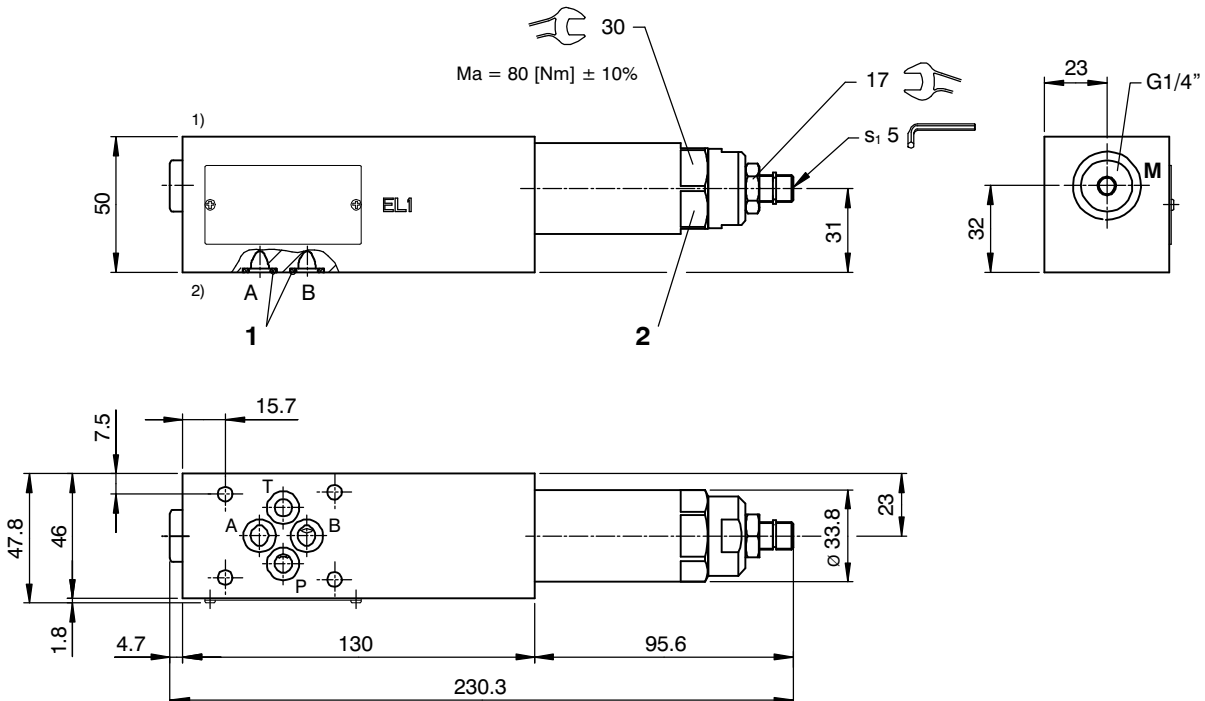

1) Valve side

2) Connections side (manifold side)

M Pressure-gauge port (with G 1/4" threaded plug, ED VSTI)

4.2 Function in A (for flow IN), with bypass check valve

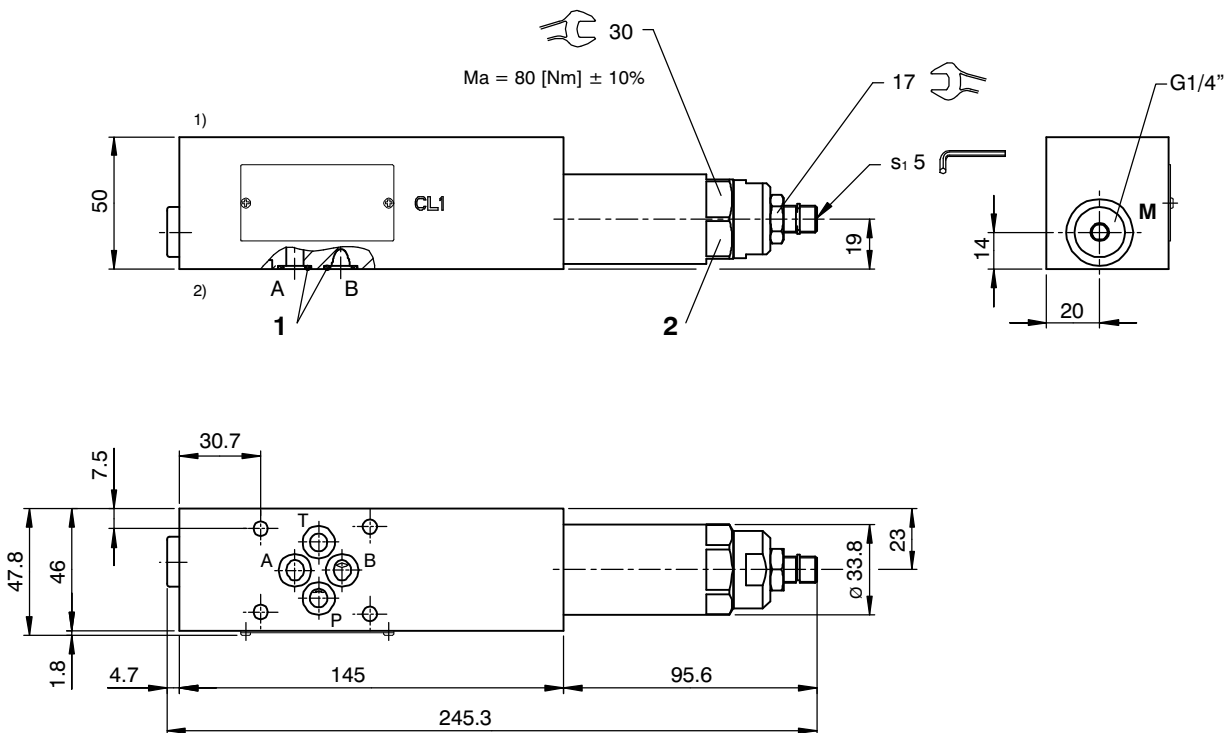

- 1) Valve side
 2) Connections side (manifold side)
 M Pressure-gauge port (with G 1/4" threaded plug, ED VSTI)

5 Installation information



IMPORTANT!

When installing the valve, make sure that the mating face (the manifold interface) aligns with the valve interface. Do not confuse the sandwich valve's manifold side and directional-valve side. Set the required pressure with the adjusting screw (s_1). After you have set the valve, lock the adjusting screw with the lock nut.



ATTENTION!

Only qualified personnel with mechanical skills may carry out any maintenance work. Generally, the only work that should ever be undertaken is to check, and possibly replace, the seals. When changing seals, oil or grease the new seals thoroughly before fitting them.

6 Performance graphs



IMPORTANT!

Detailed performance data and other hydraulic characteristics can be found in the data sheet for the 3-way pressure-reducing cartridge that is fitted (data sheet ref. no. 400-P-260701-E).

Seal kit NBR no. DS-401-N ³⁾

Item	Qty.	Description
1	4	O-ring no. 012 \varnothing 9,25 x 1,78 N90
2	1	Seal kit NBR no. DS-324-N for pressure-reducing cartridge DDRA-7L...



IMPORTANT!

³⁾ Seal kit with FKM (Viton) seals, no. DS-401-V



ATTENTION!

The performance figures in the data sheet for the cartridge valve refer just to the cartridge itself. Take into account the additional pressure drop in the body into which it is fitted.

7 Ordering code

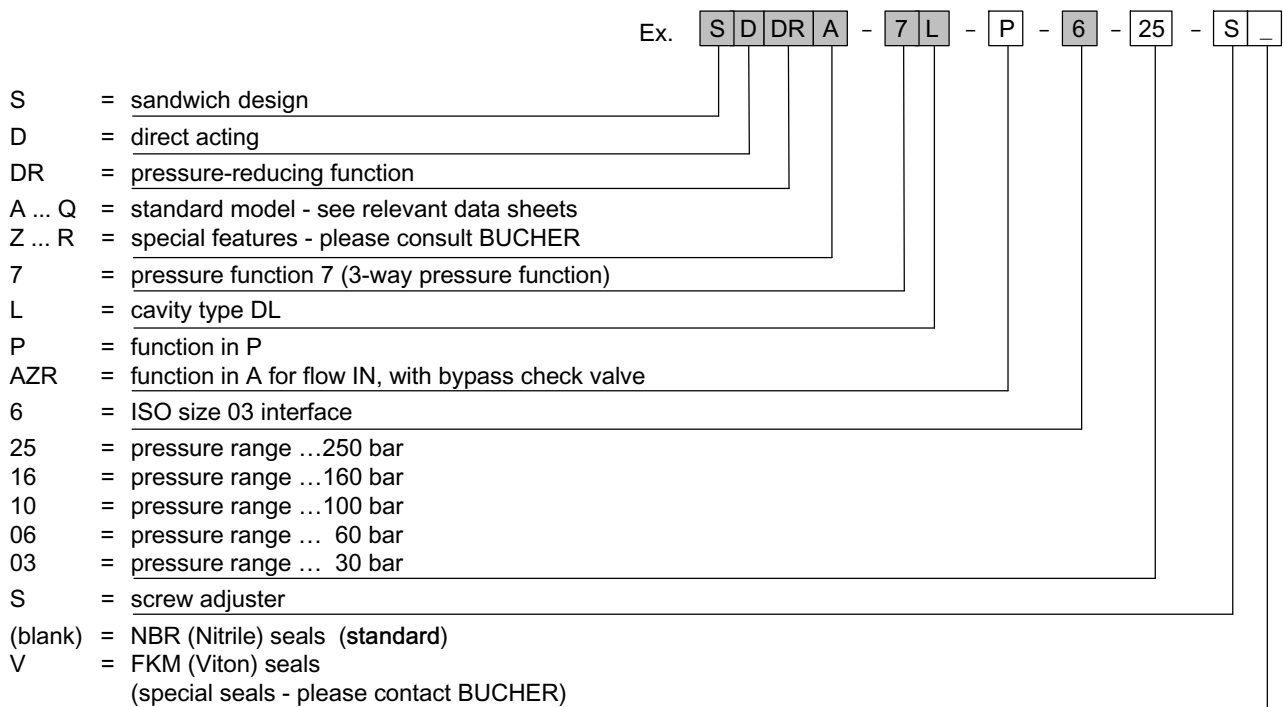

8 Related data sheets

Reference	(Old no.)	Description
400-P-030501	(i-31)	Size 03 interface to ISO 4401-03-02
400-P-260701		3-way pressure-reducing valve, size 10, series DDRA-7L...-10...

info.ch@bucherhydraulics.com

www.bucherhydraulics.com

© 2015 by Bucher Hydraulics AG Frutigen, CH-3714 Frutigen

All rights reserved.

Data is provided for the purpose of product description only, and must not be construed as warranted characteristics in the legal sense. The information does not relieve users from the duty of conducting their own evaluations and tests. Because the products are subject to continual improvement, we reserve the right to amend the product specifications contained in this catalogue.

Classification: 430.305.305.330.315.355