

Proportional Pressure-Relief Valve, ISO Size 05

$Q_{\max} = 120 \text{ l/min}$, $p_{\max} = 315 \text{ bar}$
Sandwich design, seated pilot stage
Series SDVPSA-3...

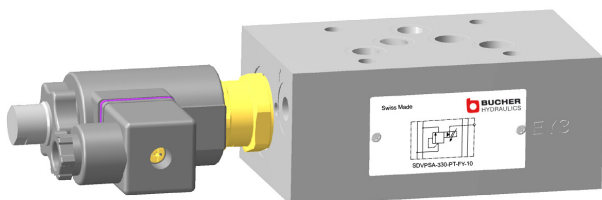

- With cartridge valve, type DVPSA-3D...-10...
- Interface to ISO 4401-05-04
- 5 pressure ranges available
- External pilot-oil drain
- Very stable operation
- External cartridge parts are zinc plated and chromited (CrVI-free)
- Sandwich body is zinc-phosphated
- The slip-on coil can be rotated, and it can be replaced without opening the hydraulic envelope
- Various plug-connector systems and voltages are available

1 Description

Series SDVPSA-3... sandwich valves are high performance, proportional pressure-relief valves with a size 05 interface to 4401-05-04. The main components of the valves are a sandwich body (stack-mounting body) and the screw-in, proportional pressure-relief cartridge, type DVPSA-3D...-10. These sandwich valves are used to limit the system pressure in mobile and industrial applications. The sandwich body is zinc-phosphated. All external parts of

the cartridge are zinc-nickel plated to DIN 50 979 and are thus suitable for use in the harshest operating environments. The slip-on coils can be replaced without opening the hydraulic envelope and can be positioned at any angle through 360°. The sandwich body is sealed at its manifold side (the connections side) by means of O-rings fitted in a seal plate that is supplied with the valve.

2 Symbol

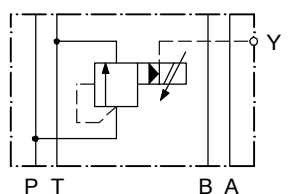

SDVPSA-3 ... -PT-FY-10...

3 Technical data

General characteristics	Description, value, unit
Designation	proportional pressure-relief valve
Design	sandwich design, seated pilot, spool-type main stage
Mounting method	4 x \varnothing 6.5 holes for M6 cap screws
Size	size 05 interface to ISO 4401-05-04 / DIN 24 340 A10
Weight	3.20 kg
Mounting attitude	unrestricted
Ambient temperature range	-25 °C ... +50 °C

Hydraulic characteristics	Description, value, unit
Maximum operating pressure	315 bar
Flow range	10...120 l/min
Nominal pressure ranges	...60 bar, ...100 bar, ...160 bar, ...250 bar, ...315 bar
Flow direction	see symbol
Hydraulic fluid	HL and HLP mineral oil to DIN 51 524; for other fluids, please contact BUCHER
Hydraulic fluid temperature range	-25 °C ... +70 °C
Viscosity range	15...380 mm ² /s (cSt), recommended 20...130 mm ² /s (cSt)
Minimum fluid cleanliness Cleanliness class to ISO 4406 : 1999	class 18/16/13

Electrical characteristics	Description, value, unit
Supply voltage	12 V DC, 24 V DC
Control current	12 V = 0...1400 mA, 24 V = 0...750 mA
Coil resistance R - cold value at 20 °C - max. warm value	12 V = 5.8 Ω / 24 V = 21 Ω 12 V = 8.6 Ω / 24 V = 32 Ω
Recommended PWM frequency (dither)	200 Hz
Hysteresis with PWM	2...4 % I _N
Reversal error with PWM	2...5 % I _N
Sensitivity with PWM	≤ 1 % I _N
Reproducibility with PWM	< 1.5 % p _N
Relative duty cycle	100 %
Protection class to ISO 20 653 / EN 60 529	IP 65 / IP 67 / IP 69K, see "Ordering code" (with appropriate mating connector and proper fitting and sealing)
Electrical connection	3-pin square plug to ISO 4400 / DIN 43 650 (standard) for other connectors, see "Ordering code"

4 Performance graphs



IMPORTANT!

Detailed performance data and other hydraulic characteristics can be found in the data sheet for the proportional pressure-relief cartridge that is fitted (data sheet ref. no. 400-P-581401-E).



ATTENTION!

The performance figures in the data sheet for the cartridge valve refer just to the cartridge itself. Take into account the additional pressure drop in the body into which it is fitted.

5 Dimensions & sectional view

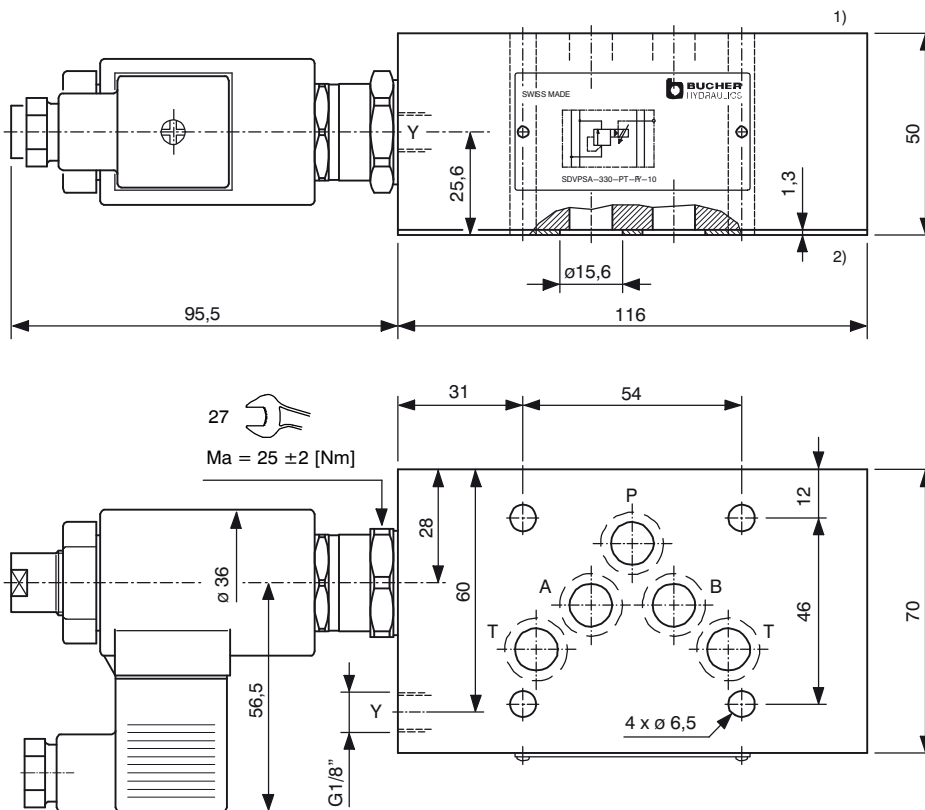

- 1) Valve side
 2) Connections side (manifold side)
 Y Pilot-oil drain (to tank without back-pressure)

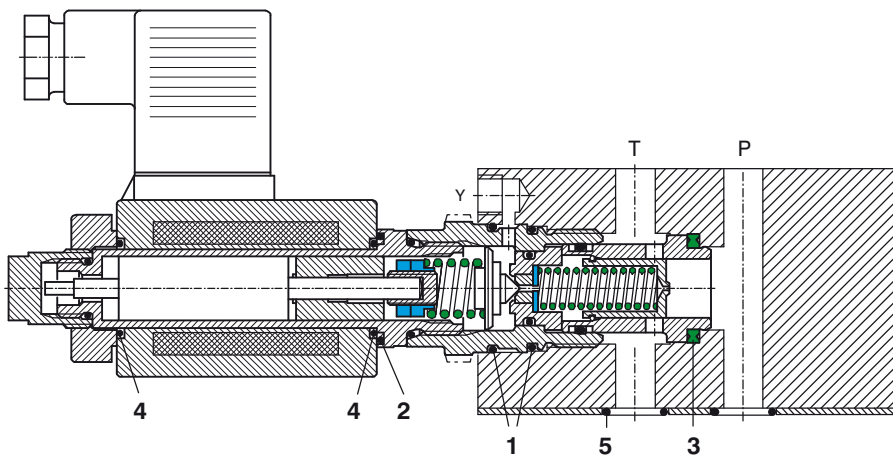

6 Installation information



IMPORTANT!

When installing the valve, make sure that the mating face (the manifold interface) aligns with the valve interface. Do not confuse the sandwich valve's manifold side and directional-valve side. No adjustments are necessary, since the cartridges are set in the factory.



ATTENTION!

To achieve the proportional pressure-relief cartridge's maximum performance rating, fit the solenoid coil as shown (with the plug pins at the left). Use the specified tightening torque when fitting the cartridge.



ATTENTION!

Only qualified personnel with mechanical skills may carry out any maintenance work. Generally, the only work that should ever be undertaken is to check, and possibly replace, the seals. When changing seals, oil or grease the new seals thoroughly before fitting them.

Seal kit no. DS-339-N

Item	Qty.	Description
1	2	O-ring no. 020 \varnothing 21.95 x 1.78 N90
2	1	O-ring \varnothing 18.00 x 2.00 Viton
3	1	Seal ring \varnothing 22.10 / 16.50 x 2.50
4	2	O-ring \varnothing 16.00 x 2.00 Viton
5	5	O-ring no. 014 \varnothing 12.42 x 1.78 N90

7 Ordering code

Ex.

S	DVP	S	A	-	3	30	-	PT	-	FY	-	10	-		24 VDC	-	
---	-----	---	---	---	---	----	---	----	---	----	---	----	---	--	--------	---	--

- S = sandwich valve
 - DVP = pressure-relief cartridge, two stage
 - S = standard solenoid (proportional)
 - A ... Q = standard model - see relevant data sheets
 - Z ... R = special features - please consult BUCHER
 - 3 = pressure function 3 (external pilot drain to Y)
 - 30 = pressure range ...315 bar
 - 25 = pressure range ...250 bar
 - 16 = pressure range ...160 bar
 - 10 = pressure range ...100 bar
 - 06 = pressure range ... 60 bar
 - PT = function from P to T
 - FY = sandwich body type
 - 10 = ISO size 05 interface
 - (blank) = NBR (Nitrile) seals (standard)
 - V = FKM (Viton) seals (special seals - please contact BUCHER)
 - ... = voltage e.g. 24 (24 V)
 - (blank) = ISO 4400 / DIN 43 650 mating plug (standard, IP 65)
 - M100 = without mating DIN plug
 - C = Kostal plug connection (IP 65)
 - JT = Junior Timer radial plug connection (with protection diode, IP65)
 - IT = Junior Timer axial plug connection (with protection diode, IP65)
 - D = Deutsch plug connection DT04-2P (IP 67/69K)
 - DT = Deutsch plug connection DT04-2P (with protection diode, IP 67/69K)
 - S = AMP Superseal 1.5 (IP 67) / Metri-Pack 150 (IP 65)
 - F = flying leads (500 mm)
- } mating plug not supplied

8 Related data sheets

Reference	(Old no.)	Description
400-P-050101	(i-41)	Size 05 interface to ISO 4401-05-04
400-P-120110	(W-2.141)	Coils for screw-in cartridge valves
400-P-581401	(P-51.4 A_1)	Proportional pressure-relief valve, size 10, series DVPSA-3D...-10...
400-P-810901	(G-45)	Seal plate, type DB-10

info.ch@bucherhydraulics.com

www.bucherhydraulics.com

© 2015 by Bucher Hydraulics AG Frutigen, CH-3714 Frutigen

All rights reserved.

Data is provided for the purpose of product description only, and must not be construed as warranted characteristics in the legal sense. The information does not relieve users from the duty of conducting their own evaluations and tests. Because the products are subject to continual improvement, we reserve the right to amend the product specifications contained in this catalogue.

Classification: