



TANDEM FZOT

Pompa ad Ingranaggi
Gear Pump

CODICE DI ORDINAZIONE / ORDERING CODE

200 FZO 036 D S T

21 UNI 222

ROTAZIONE/ROTATION
D = DESTRO/CLOCKWISE
S = SINISTRO/ANTICLOCKWISE

CILINDRATA/DISPLACEMENT

TIPO/TYPE

POMPA AD INGRANAGGI/GEAR PUMP

UNI
21-222

FZO 36 T
FZO 43 T
FZO 57 T
FZO 65 T
FZO 90 T

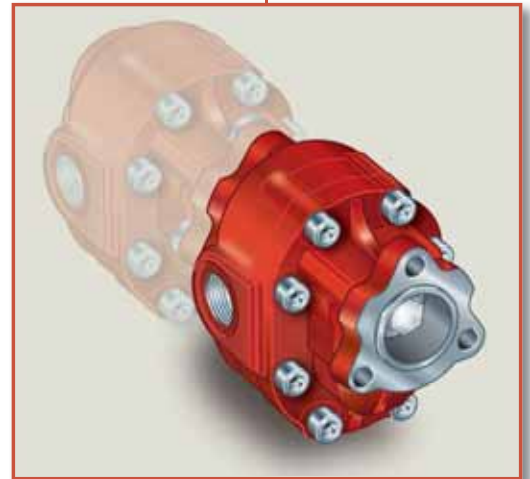

CARATTERISTICHE E DATI TECNICI / SPECIFICATIONS AND TECHNICAL DATA

TIPO TYPE	CODICE CODE	CILINDRATA DISPLACEMENT cm ³ /rev.	A mm	B mm	C ASPIRAZIONE INLET	D MANDATA OUTLET	PESO WEIGHT kg
FZO 36 T	200FZ0036 D S T	36	99.5	160	3/4" G	1/2" G	9.3
FZO 43 T	200FZ0043 D S T	43	104.5	165	1" G	3/4" G	10.5
FZO 57 T	200FZ0057 D S T	57	111.5	175	1" G	3/4" G	11.3
FZO 65 T	200FZ0065 D S T	65	116.5	180	1" G	3/4" G	11.8
FZO 90 T	200FZ0090 D S T	84	126	195	1" 1/4 G	1" G	12.8

KIT ACCOPPIAMENTO POSTERIORE:
per pompa ad ingranaggi tipo

REAR MOUNTING KIT:
for gear pump type

PE	
B	198KPP02000
NF	
FZO	
NFL	198KPP03000
GP	

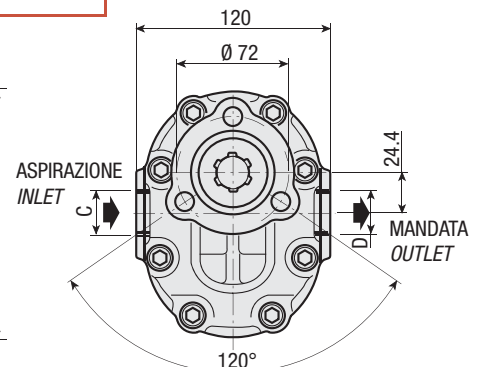
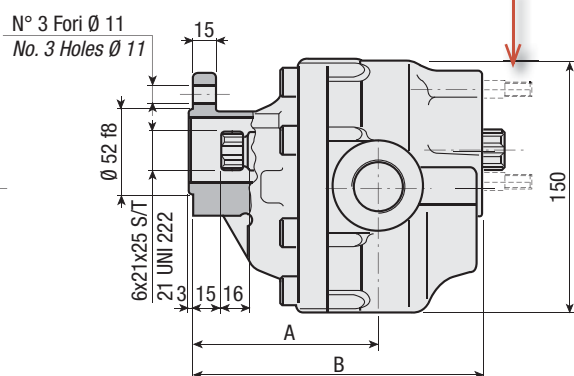
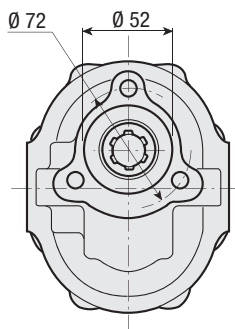

DATI TECNICI / TECHNICAL DATA

ESEMPIO CICLI LAVORO / EXAMPLE OF WORKING CYCLES

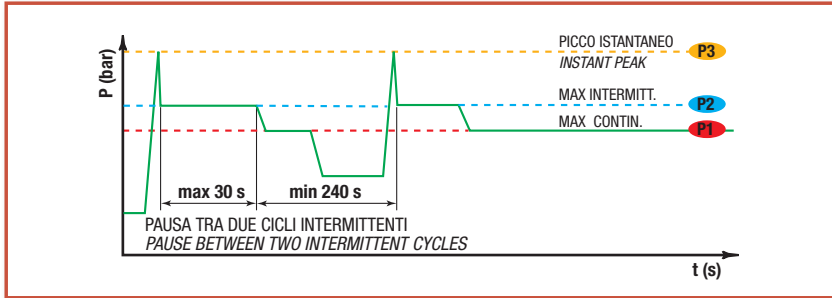

Pressione d'aspirazione: Inlet pressure:	0.7 ÷ 1.5 bar (assoluti/absolute)
Campo viscosità lavoro: Operating viscosity range:	12 ÷ 100 cSt
Temperatura fluido °C (t): Fluid temperature °C (t):	-10° + 80° C

Pressione Lavoro Working Press. P2	Contaminazione / Contamination		Filtro / Filter βx = 75
	NAS 1638	ISO 4406	
≤ 200 bar	12	21/18	40 μm
≥ 200 bar	11	20/17	25 μm

◀ **FILTRAZIONE CONSIGLIATA (ritorno o mandata)**
RECOMMENDED FILTERING (return or outlet)

TIPO / TYPE			FZ036T	FZ043T	FZ057T	FZ065T	FZ090T
Cilindrata Displacement	Vg	cm ³ /n cm ³ /rev.	36	43	57	65	84
Pressione massima continua Max continuous operating pressure	P1	bar	300	280	240	220	210
Pressione massima intermittente Max intermitt. operat. press.	(max 30 s) P2		325	305	265	240	230
Pressione massima di picco Max peak pressure	(≤ 0.1 s) P3		450	400	380	350	300
Velocità massima intermittente Max intermittent speed	(P ≤ 20 bar) n3	n/min r.p.m.	3500	3500	3500	3500	3500
Velocità massima continua Max continuous speed	(≤ P1) n1		2200	2200	2000	1800	1500
Velocità minima intermittente Min intermittent speed	(≤ P2 x 0.5) (max 30 s) n4		350	350	300	300	300

POTENZA ASSORBITA / POWER INPUT

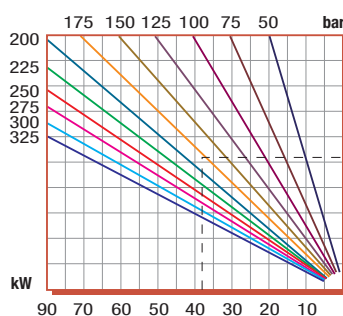

PORTATA / CAPACITY

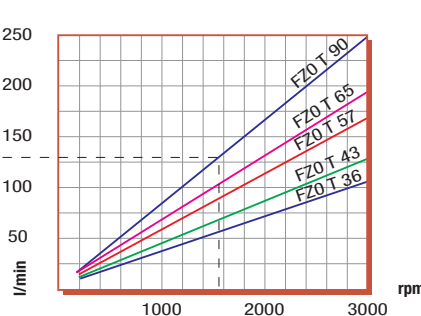

Coppia massima prelevabile
sull'albero della 1° pompa 300 Nm.
Max torque on the primary pump
300 Nm.

DIAGRAMMI / DIAGRAMS

RENDIMENTO VOLUMETRICO / VOLUMETRIC EFFICIENCY

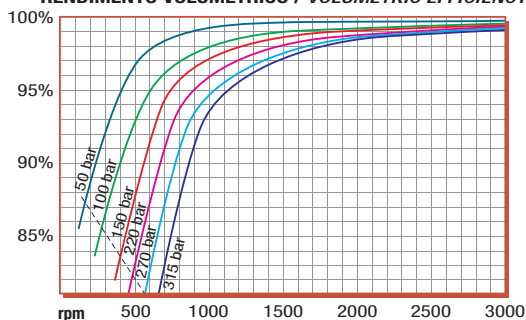

COPPIA ASSORBITA / DRIVE TORQUE

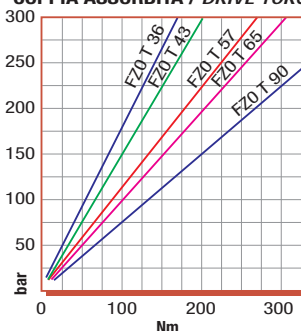

RILIEVI ESEGUITI CON OLIO
ISO VG 46 A 50° C (√= 30 cSt)
THE ABOVE SPECIFICATIONS
REFER TO OIL TYPE ISO
VG 46 AT 50° C (√=30 cSt)