



BIDIREZIONALE  
BI-ROTATIONAL

# PE

UNI  
21-222

PE 14  
PE 19  
PE 25  
PE 30

Pompa a Pistoni  
Piston Pump



CODICE DI ORDINAZIONE / ORDERING CODE

201 PE 014 0 00

21 UNI 222

VERSIONE / VERSION

CILINDRATA / DISPLACEMENT

TIPO / TYPE

POMPA A PISTONI / PISTON PUMP

CARATTERISTICHE E DATI TECNICI / SPECIFICATIONS AND TECHNICAL DATA

TIPO TYPE	CODICE CODE	A mm	B mm	C mm	D mm	E ASPIRAZIONE INLET	F MANDATA OUTLET	PESO WEIGHT kg
PE 14	201PE014000	253	112	63	95	1" G	1" G	10.1
PE 19	201PE019000							10.0
PE 25	201PE025000							9.9
PE 30	201PE030000							9.7

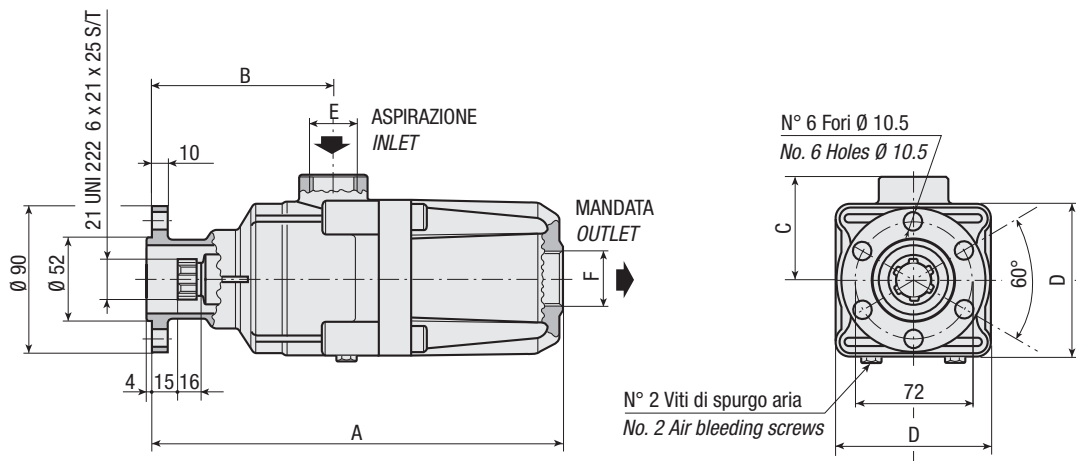

**DATI TECNICI / TECHNICAL DATA**

**ESEMPIO CICLI LAVORO / EXAMPLE OF WORKING CYCLES**

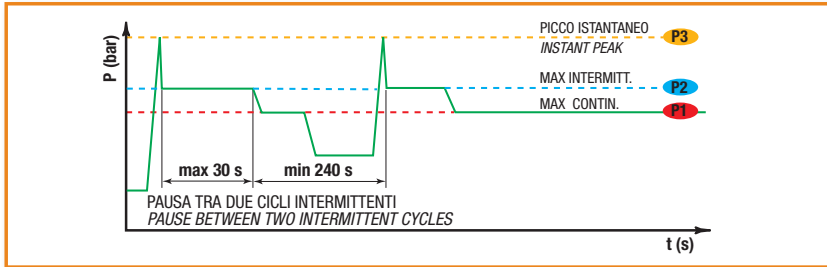

Pressione d'aspirazione: Inlet pressure:	0.7 ÷ 1.5 bar (assoluti/absolute)
Campo viscosità lavoro: Operating viscosity range:	12 ÷ 100 cSt
Temperatura fluido °C (t): Fluid temperature °C (t):	-10° + 80° C

Pressione Lavoro Working Press. P2	Contaminazione / Contamination		Filtro / Filter βx = 75
	NAS 1638	ISO 4406	
≤ 200 bar	12	21/18	40 μm
≥ 200 bar	11	20/17	25 μm

◀ **FILTRAZIONE CONSIGLIATA (ritorno o mandata)**  
**RECOMMENDED FILTERING (return or outlet)**

TIPO / TYPE		PE14	PE19	PE25	PE30	
Cilindrata Displacement	Vg	cm <sup>3</sup> /n cm <sup>3</sup> /rev.	16.0	21.3	26.7	32.0
Pressione massima continua Max continuous operating pressure	P1	bar	330	330	330	330
Pressione massima intermittente Max intermitt. operat. press. (max 30 s)	P2		360	360	360	360
Pressione massima di picco Max peak pressure (≤ 0.1 s)	P3		500	500	500	500
Velocità massima intermittente Max intermittent speed (P ≤ 20 bar)	n3	n/min r.p.m.	2400	2400	2400	2400
Velocità massima continua Max continuous speed (≤ P1)	n1		1800	1800	1800	1800
Velocità minima intermittente Min intermittent speed (≤ P2 x 0.5) (max 30 s)	n4		400	400	350	350

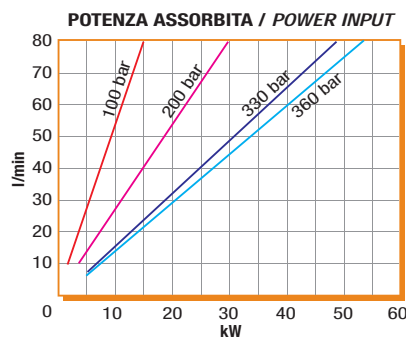
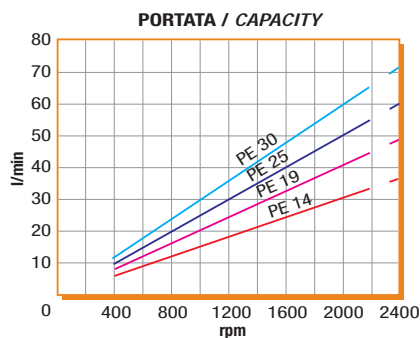

**DIAGRAMMI / DIAGRAMS**

**RENDIMENTO VOLUMETRICO / VOLUMETRIC EFFICIENCY**

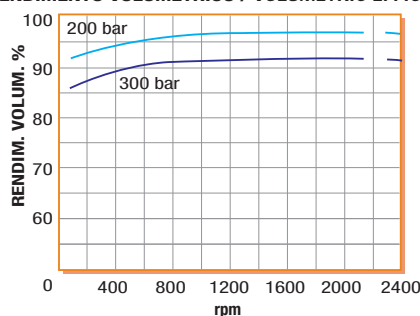

**COPPIA ASSORBITA / DRIVE TORQUE**

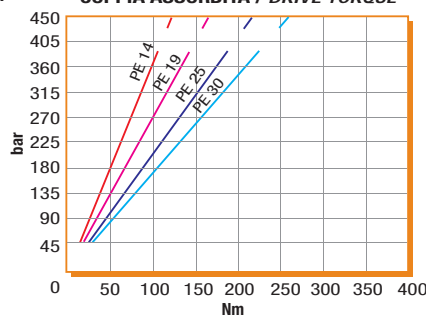

RILIEVI ESEGUITI CON OLIO  
ISO VG 46 A 50° C (√= 30 cSt)  
THE ABOVE SPECIFICATIONS  
REFER TO OIL TYPE ISO  
VG 46 AT 50° C (√=30 cSt)

