

Speed sensor for Sunfab hydraulic motors SCM

Sunfab speed sensor is available on ISO/SAE/DIN motors (not M2), displacement 010-130 cc. The sensor is a two channel hall effect sensor and has two frequency outputs both giving square wave signals, phase shifted $\sim 90^\circ$. It's available in both PNP and NPN versions.

The frequency is determined by:

$$f = \frac{30 \cdot n}{60} = \frac{n}{2}, n \text{ (rpm)}$$

- It can operate at high temperatures.
- The speed is detected from the gears on the cylinder block. Since the sensor is working with two channels the rotation direction can be detected.
- The number of gears is 30 for all motor displacements.
- Motors manufactured prepared for speed sensor can also have a sensor fitted afterwards.



Technical data

Power supply	8 – 32V DC
Current consumption	< 33 mA at 24 V both outputs low < 23 mA at 24 V both outputs high
Frequency range	1 – 6000 Hz
Number of pulses/rev.	30
Maximum output current	500 mA at 24 V, +25 °C / 50 % duty cycle 50 mA at 24 V, +125 °C / 50 % duty cycle
Output	NPN with 5k pull-up resistor PNP with 5k pull-down resistance
Output signal level	Low: ≤ 2V; High: ≥ 5V
Load impedance	≥ 10 kOhm
Load capacitance	≤ 2,2 nF
Short circuit immunity	Yes
Reverse polarity protection	Yes
Cable conductor assignment	Brown: 8 – 32V DC Blue: ground Black: frequency signal 1 White: frequency signal 2
Cable	4-core, 0,75 mm ² , core end sleeve
Cable length	~400 mm of which 80 mm core
Bending radius of cable	≥ 40 mm
Measuring distance	~1,7 mm (sensor top to teeth of cylinder block)
Weight	~100 g

Environmental conditions

Operating temperature range	-40 – +125 °C
Environmental resistance of housing	Brine and various hydraulic oils
Storage	Storage in a dry place
Max pressure on sensing surface	10 bar
Max. tensile load on cable	75 N
Degree of protection (IEC 529)	IP67, IP69K
Vibration resistance (IEC 68-2-6, IEC 68-2-36)	f = 5 – 57 Hz (1,5 mm p-p) f = 57 – 2000 Hz (10g)
Shock resistance (DIN 40046, IEC 68-2-27)	3x: a = 15g, 11 ms, in every direction 3x: a = 25g, 6 ms, in every direction
EMC	Radiated interference (ISO 11452): 300 mV Level A Load dump (ISO 7637-2): 200 V, Performance level C 1000 cycles: -40 °C - +125°C air
Temperature change test	1 m
Drop test (IEC 68-2-32)	-55 °C / 16 h
Low temperature test (IEC 68-2-1)	+125 °C / 16 h
Dry heat test (IEC 68-2-2)	20 cycles, water immersion test: +120 °C air to +23 °C water
Temperature shock	

Mounting

Mounting principle	Asymmetric flange for directional dependence and failsafe fitting
Tightening torque	Tighten the screws with 10 Nm torque First tighten both screws gently and then use with 10 Nm O-ring shall always be mounted
Mounting and safety precautions	Do not mount electrical connections with an open current Only install when machinery is out of operation
Housing material	Brass / plastic (PA6 GF30)

Diagram

Block circuit diagram PNP

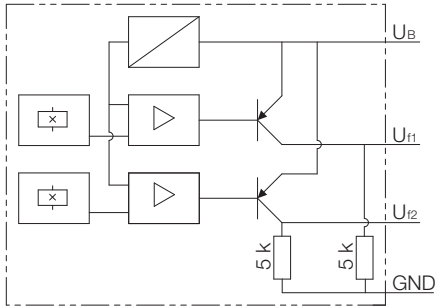

Output signals PNP

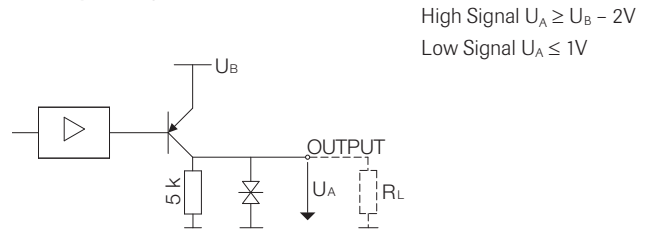

Block circuit diagram NPN

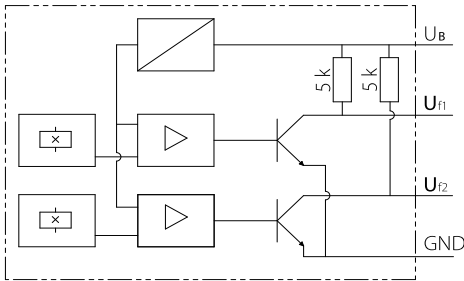

Output signals NPN

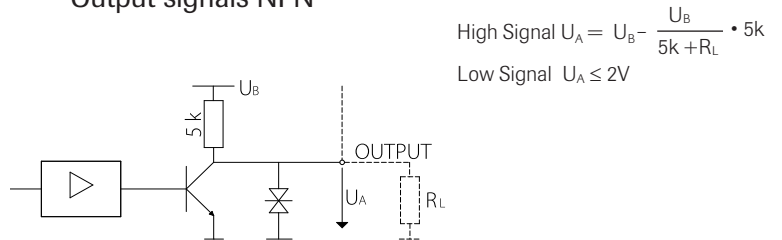

Clockwise rotation

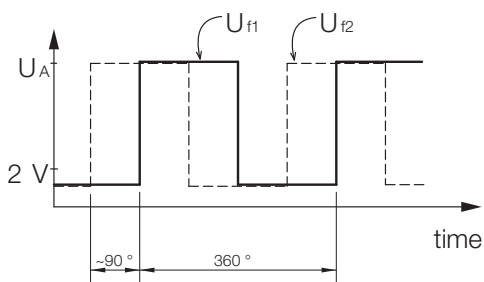

Counter-clockwise rotation

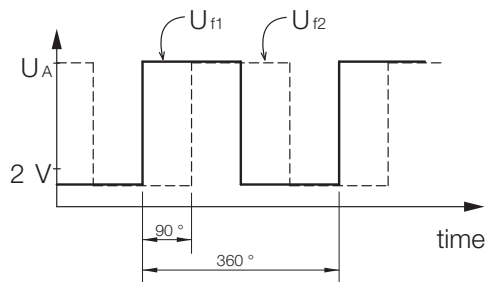

Ordering code

P1	Prepared for speed sensor
S1	Fitted speed sensor type PNP
S2	Fitted speed sensor type NPN

Example: Motor with speed sensor
SCM-025W-V-I42-K30-K3G-1S1

- Motor with speed sensor

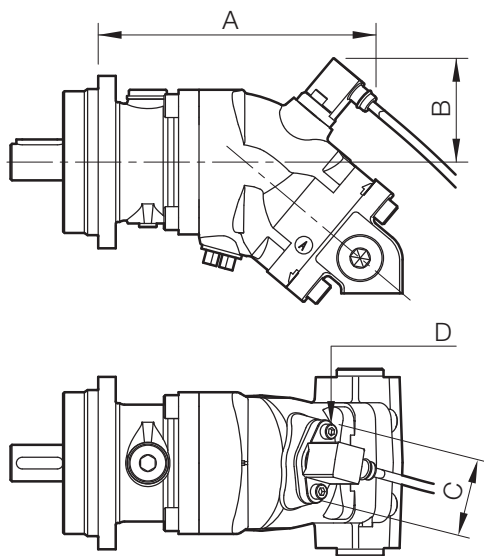

Example: Motor prepared for speed sensor
SCM-025W-V-I42-K30-K3G-1P1

- Motor prepared for speed sensor mounted with a steel plug

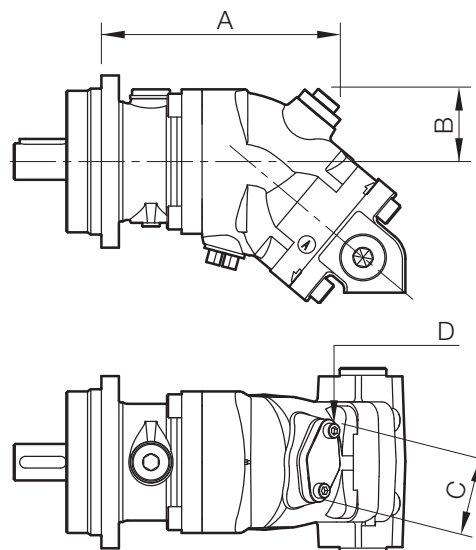

Dimensions

Type SCM-ISO and SAE [mm]	A	B	C	D
010 - 034 cc ISO & SAE	190	71	58	M6x16
010 - 034 cc DIN	186			
040 - 064 cc ISO & SAE	216	74		
040 - 064 cc DIN	210			
084 - 108 cc ISO, DIN & SAE C	223	80		
084 - 130 cc SAE D	215			

Dimensions

Type SCM-ISO and SAE [mm]	A	B	C	D
010 - 034 cc ISO & SAE	164	50	60	M6x16
010 - 034 cc DIN	160			
040 - 064 cc ISO & SAE	190	53		
040 - 064 cc DIN	184			
084 - 108 cc ISO, DIN & SAE C	201	61		
084 - 130 cc SAE D	192			

NOTES

1. Line to sensor must be shielded
2. Lines to electronic unit must not be routed close to other power conducting lines in the machine or vehicle
3. A sufficiently large distance to radio systems must be maintained
4. If longer connecting lines are used, 5 m, the lines for each frequency signal should be separately shielded

Sunfab reserves the right to make changes in design and dimensions without notice. Printing and typesetting errors reserved.
© Copyright 2015 Sunfab Hydraulics AB. All Rights Reserved.