

## M - 28 A a

### Stacking Throttle / Check Valve, ISO size 7

- Meter-out flow control in A, B or A and B
- Meter-in flow control in A, B or A and B
- Interface to ISO 4401 / CETOP R35H size 07, NFPA D07, DIN 24 340 A16

Series SRDB ...

260 l/min, 350 bar

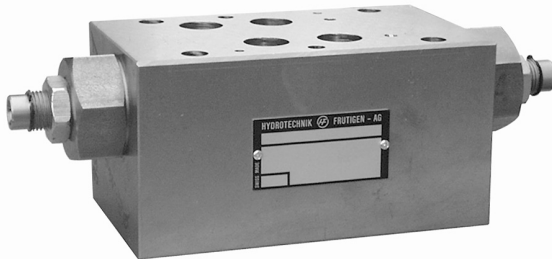

#### SYMBOLS METER-OUT CONTROL

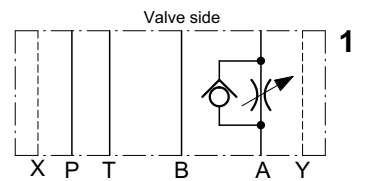

SRDB-AA-16

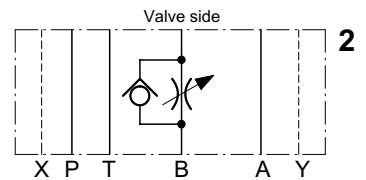

SRDB-BA-16

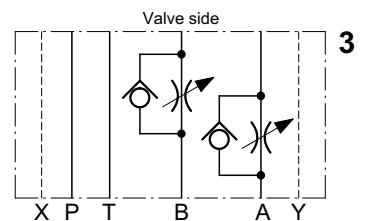

SRDB-ABA-16

#### DIMENSIONS - METER-OUT FUNCTIONS

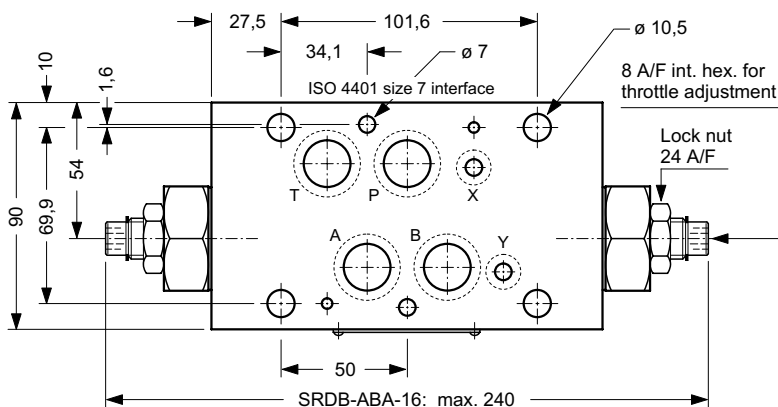
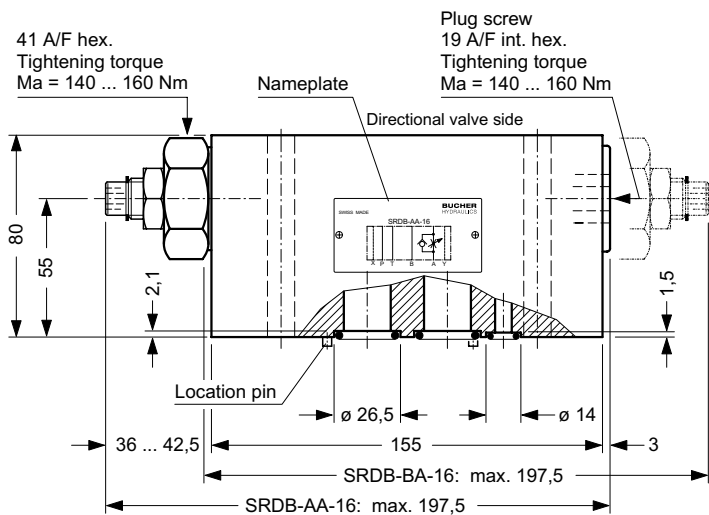

Option:  
Adjuster style H  
Hand knob

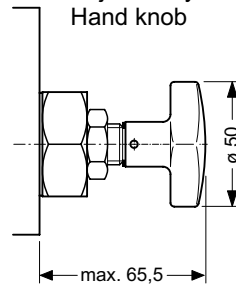

#### Application example

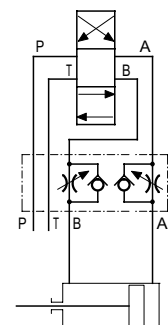

Meter-out control  
(SRDB-ABA-16)

#### DESCRIPTION

These throttle/check valves use the well known 'sandwich' principle - they are mounted between a directional valve and another control module or the sub-plate.

The throttle/check elements allow vari-

able restriction of the flow leaving the actuator ('meter-out' flow control).

Flow enters the actuator without restriction through the integral check valve.

The meter-out function creates a 'hydraulic restraint for the actuator for cases

where the external load varies greatly, perhaps even becoming negative (symbols 1 ... 3).

Sealing at the manifold-side (bottom) interface is by means of O-rings fitted in counterbores in the stacking body.

## DIMENSIONS - METER-IN FUNCTION

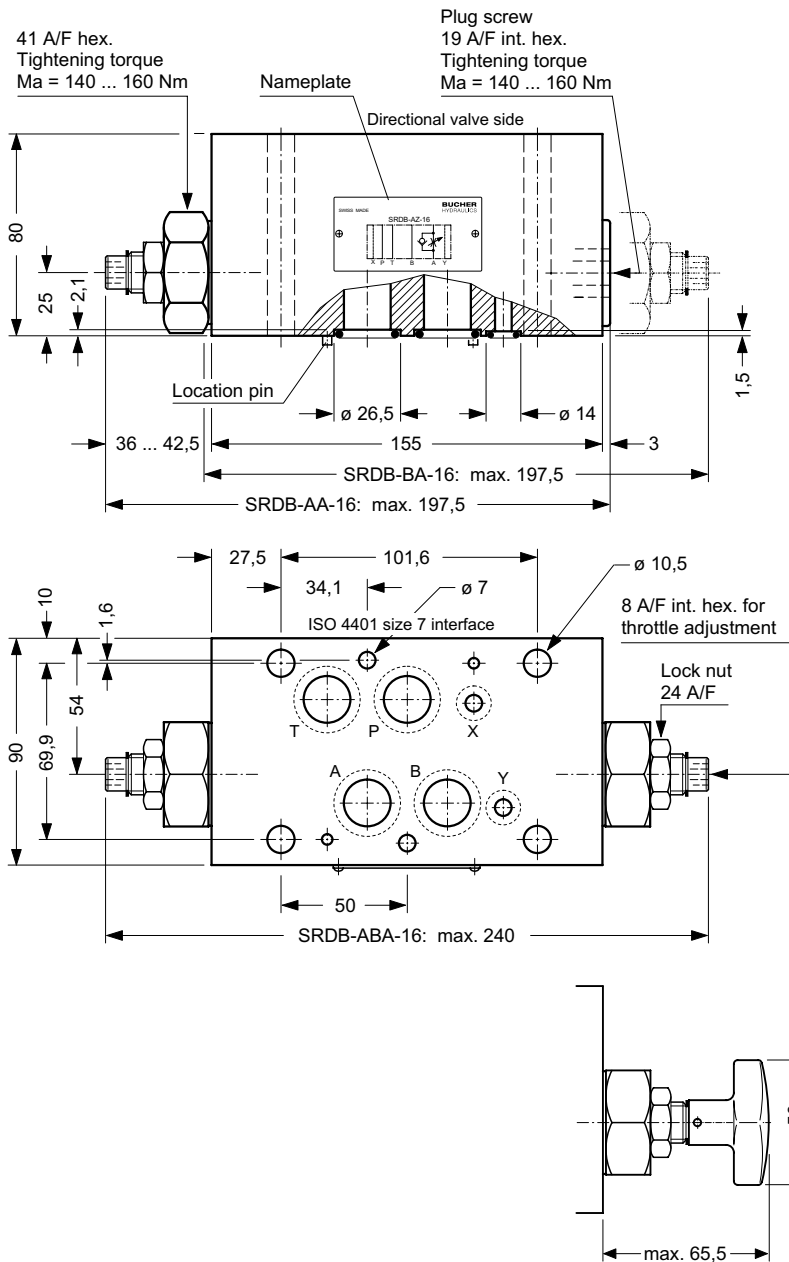

## SYMBOLS METER-IN CONTROL

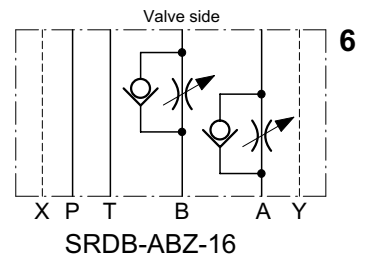
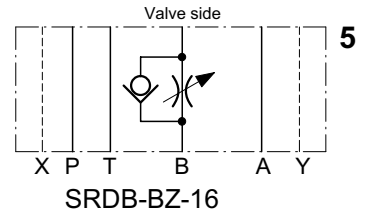
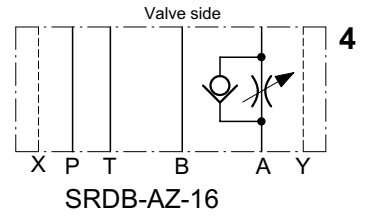

## Application example

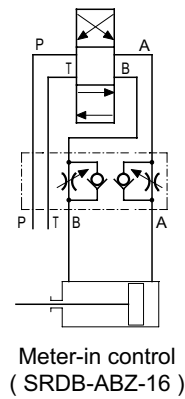

## DESCRIPTION

These throttle/check valves use the well known 'sandwich' principle - they are mounted between a directional valve and another control module or the subplate.

The throttle/check elements allow vari-

able restriction of the flow entering the actuator ('meter-in' flow control).

Flow leaves the actuator without restriction through the integral check valve.

The meter-in function is normally used when there is a steady resistance from

the cylinder or motor (symbols 4 ... 6).

Sealing at the manifold-side (bottom) interface is by means of O-rings fitted in counterbores in the stacking body.

## SCHMATIC SECTION

showing the relevant ports (Ex. SRDB-AA-16)

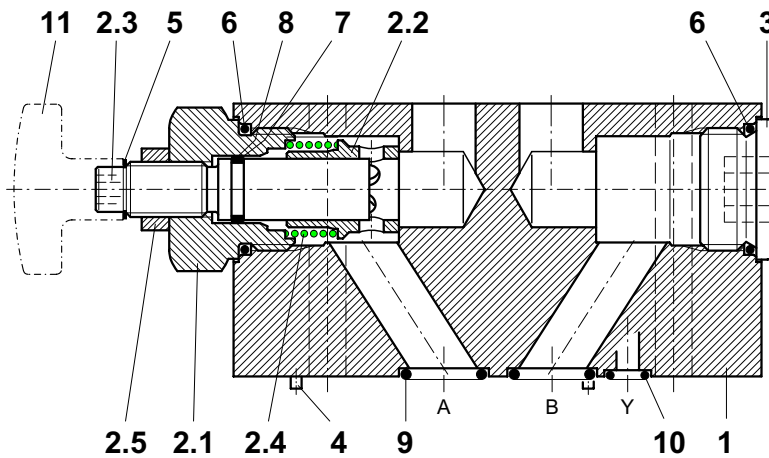

## COMPONENTS / SERVICE PARTS

It.	Qty.	Description				
1	--	Stacking body	90 x 80 x 155 type X3-16			
1	1	Stacking body	90 x 80 x 155 type XZ3-16			
2	2	Functional insert RDB-16, comprising **)				
2.1	2	1	2	1**) Guide nut	41 A/F hex. x 37	
2.2	2	1	2	1**) Metering sleeve	ø 28 x 33	
2.3	2	1	2	1**) Adjusting screw	ø 18 x 81,8	
2.4	2	1	2	1**) Spring	1,4 x 28,2 x 27 iG = 4	
2.5	2	1	2	1**) Hex. nut	M 16 x 1,5 DIN 439 B	
3	--	1	--	1	Plug screw	M 36 x 1,5 DIN 908
4	2	2	2	2	Roll pin (heavy)	ø 3 x 8 DIN 7344
				Seal kit no. DS-270, comprising *)		
5	2	1	2*	1**) Snap ring	ø 14 type SS	
6	2	2	2*	2**) O-ring no. 124	ø 31,42 x 2,62 N90	
7	2	1	2*	1**) O-ring no. 015	ø 14,00 x 1,78 N90	
8	2	1	2*	1**) Backup ring	ø 18 / 15,2 x 1,2	
9	4	4	4*	4	O-ring no. 118	ø 21,89 x 2,62 N90
10	2	2	2*	2	O-ring	ø 10,00 x 2,00 N90
11	(2)	(1)	(2)	(1)	Hand knob, complete (option)	

\*) = part of seal kit no. DS-270  
 \*\*) = available as service part

SRDB-AA-16 / SRDB-BA-16  
 SRDB-ABA-16  
 SRDB-AZ-16 / SRDB-BZ-16  
 SRDB-ABZ-16

TO ORDER SERVICE PARTS, STATE:

- complete unit model code from the nameplate including the design number
- data sheet number, including issue date
- part item number from above list
- part description from above list
- quantity required

## INSTALLATION AND SERVICING

MUST BE CARRIED OUT WITH CARE, AND BY QUALIFIED PERSONNEL ONLY

At installation, make sure that the valve interfaces align with the interfaces of the mating surfaces and do not confuse the

directional valve ('top') and manifold ('bottom') faces of the valve.

When changing seals, the new seals must be thoroughly oiled or greased before fitting them to the valve.

Use the specified tightening torque when fitting the guide nut item 2.1 and the plug screw item 3.

## MAIN CHARACTERISTICS

Type	stacking throttle / check valve
Design	spool type
Mounting method	stack mounting
Size	ISO 4401 size 07, nominal 16 mm
Mass	SRDB-AA / -AZ / SRDB-BA / -BZ = 7.35 kg SRDB-ABA / SRDB-ABZ = 7.70 kg
Mounting attitude	unrestricted
Flow direction	see symbols
Operating pressure	... 350 bar in P, A, B and T
Cracking pressure through check valve	approx. 0.7 bar
Fluids	hydraulic oils HL and HLP to DIN 51 524 other fluids - contact BHFRU
Min. fluid cleanliness	18/14 to ISO 4406 / CETOP RP70H 8 ... 9 to NAS 1638
Fluid temperature range	-20° ... + 60° C
Viscosity range	10 ... 300 cSt
Flow rate Q max.	260 l/min

## PERFORMANCE DATA

measured with oil viscosity 33 cSt

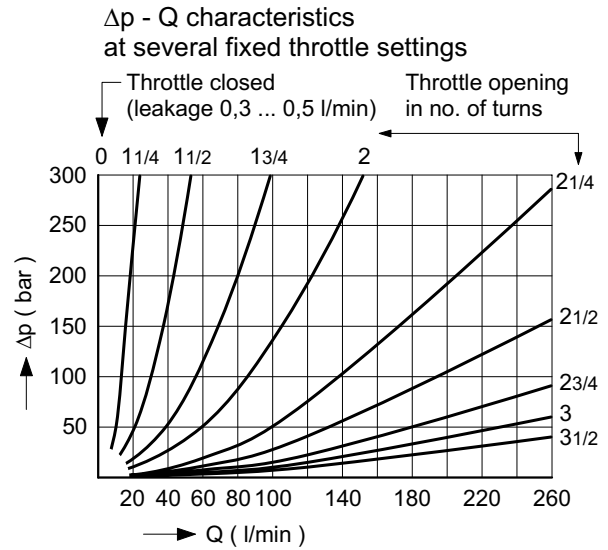
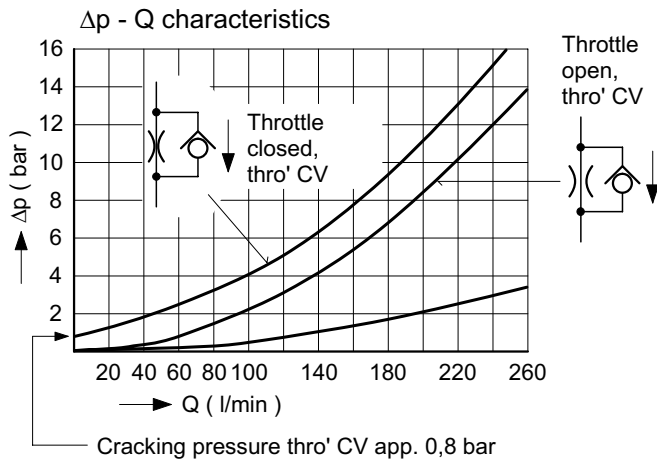

## MODEL CODE KEY

Stack mounting valve

Throttle / check function

A ... Q = standard model per relevant data sheet

Z ... R = special features by arrangement

A = function in A

B = function in B

AB = function in A and B

A = meter-out function (see symbols 1 ... 3)

Z = meter-in function (see symbols 4 ... 6)

16 = ISO 4401 size 07 interface, nominal 16 mm

(blank) = hex. skt. screw adjuster (**standard**)

H = hand knob adjuster (option)

(blank) = Nitrile seals (**standard**)

V = Viton seals

Special seals by arrangement (contact BHFRU)

1 ... 9 = design no. (omit when ordering)

Ex.

S R D B - AB A - 16 - - - 1

## RELATED DATA SHEETS

i - 51 DIN 24 340 A16 interface

i - 00 Table of interface equivalents

info.ch@bucherhydraulics.com

www.bucherhydraulics.com

© 2015 by Bucher Hydraulics AG Frutigen, CH-3714 Frutigen

All rights reserved.

Data is provided for the purpose of product description only, and must not be construed as warranted characteristics in the legal sense. The information does not relieve users from the duty of conducting their own evaluations and tests. Because the products are subject to continual improvement, we reserve the right to amend the product specifications contained in this catalogue.