

2/2 Solenoid Operated Seat Valve, ISO Size 05

$Q_{\max} = 140 \text{ l/min}$, $p_{\max} = 350 \text{ bar}$

Sandwich design, bidirectional seat-valve shut-off, electrically operated, two stage
 Series SWS22...NCB-...-10...

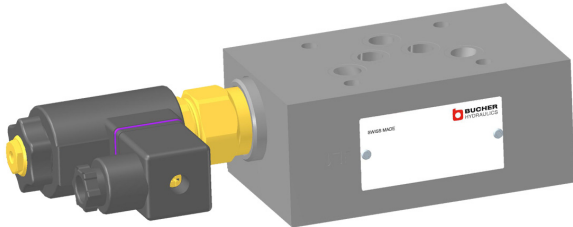

- With cartridge valve, type WS22G / O...-10...
- Interface to ISO 4401-05-04
- With bidirectional seat-valve shut-off
- Inline models in A, B or A and B
- De-energised open or closed
- The slip-on coil can be rotated, and it can be replaced without opening the hydraulic envelope
- Various plug-connector systems and voltages are available
- External cartridge parts are zinc plated and chromited (CrVI-free)
- Sandwich body is zinc-phosphated

1 Description

Series SWS22...NCB-...-10... sandwich valves are high performance, 2/2 solenoid operated seat valves with a size 05 interface to ISO 4401-05-04. The main components of the valves are a sandwich body (stack-mounting body) and the screw-in cartridge (type WS22G / O...-10...). The 2/2 solenoid operated cartridge seat valve is designed on the poppet/seat principle, and is therefore virtually leak-free in both directions of flow (bidirectional seat-valve shut-off). These sandwich valves can be supplied as de-energised-closed or de-energised-open models, as inline in A, B or A and B functions. These 2/2 solenoid operated seat valves are predominantly used in certain mobile and industrial ap-

plications where leak-tight shut-off functions are crucially important. Examples are where loads, tensions, or clamping forces must be held without leakage. The sandwich body is zinc-phosphated. All external parts of the cartridge are zinc-nickel plated to DIN 50 979 and are thus suitable for use in the harshest operating environments. The slip-on coils can be replaced without opening the hydraulic envelope and can be positioned at any angle through 360°. The sandwich body is sealed at its manifold side (the connections side) by means of O-rings fitted in a seal plate that is supplied with the valve.

2 Technical data

General characteristics	Description, value, unit
Designation	2/2 solenoid operated seat valve
Design	sandwich design, bidirectional seat-valve shut-off, electrically operated, two stage
Mounting method	4 x Ø 6.5 holes for M6 cap screws
Size	size 05 interface to ISO 4401-05-04 / DIN 24 340 A10
Weight	3.25 ... 3.85 kg
Mounting attitude	unrestricted
Ambient temperature range	-25 °C ... +50 °C
Hydraulic characteristics	Description, value, unit
Maximum operating pressure	350 bar
Maximum flow rate	140 l/min
Flow direction	see symbol
Hydraulic fluid	HL and HLP mineral oil to DIN 51 524; for other fluids, please contact BUCHER
Hydraulic fluid temperature range	-25 °C ... +80 °C

Hydraulic characteristics	Description, value, unit
Viscosity range	10...500 mm ² /s (cSt), recommended 15...250 mm ² /s (cSt)
Minimum fluid cleanliness Cleanliness class to ISO 4406 : 1999	class 20/18/15
Electrical characteristics	Description, value, unit
Supply voltage	12 V DC, 24 V DC 115 V AC, 230 V AC (50 ... 60 Hz)
Supply voltage tolerance	± 10 %
Nominal power consumption	V DC = 27 W V AC = 25 W
Relative duty cycle	100 %
Protection class to ISO 20 653 / EN 60 529	IP 65 / IP 67 / IP 69K, see "Ordering code" (with appropriate mating connector and proper fitting and sealing)
Electrical connection	3-pin square plug to ISO 4400 / DIN 43 650 (standard) for other connectors, see "Ordering code"

3 Symbol

Function in A, B or A and B – de-energised closed (inline model)

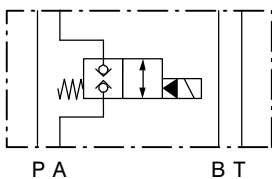

SWS22GNCB-A-JL-10...

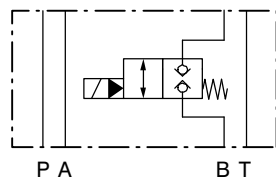

SWS22GNCB-B-JL-10...

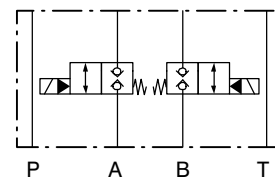

SWS22GNCB-AB-JL-10...

Function in A, B or A and B – de-energised open (inline model)

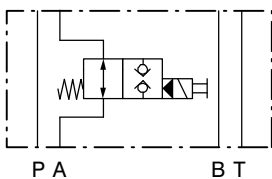

SWS22ONCB-A-JL-10...

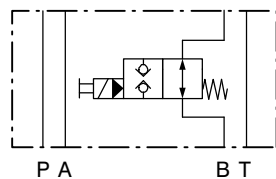

SWS22ONCB-B-JL-10...

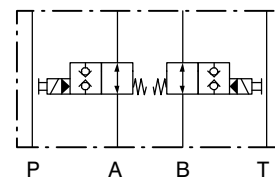

SWS22ONCB-AB-JL-10...

4 Performance graphs



IMPORTANT!

Detailed performance figures and other hydraulic characteristics can be found in the data sheet for the 2/2 solenoid operated cartridge valve that is fitted (Ref. No. 400-P-131101-E).



ATTENTION!

The performance figures in the data sheet for the cartridge valve refer just to the cartridge itself. Take into account the additional pressure drop in the body into which it is fitted.

5 Dimensions & sectional view

5.1 Solenoid operated seat valve, function in A and B (inline model)

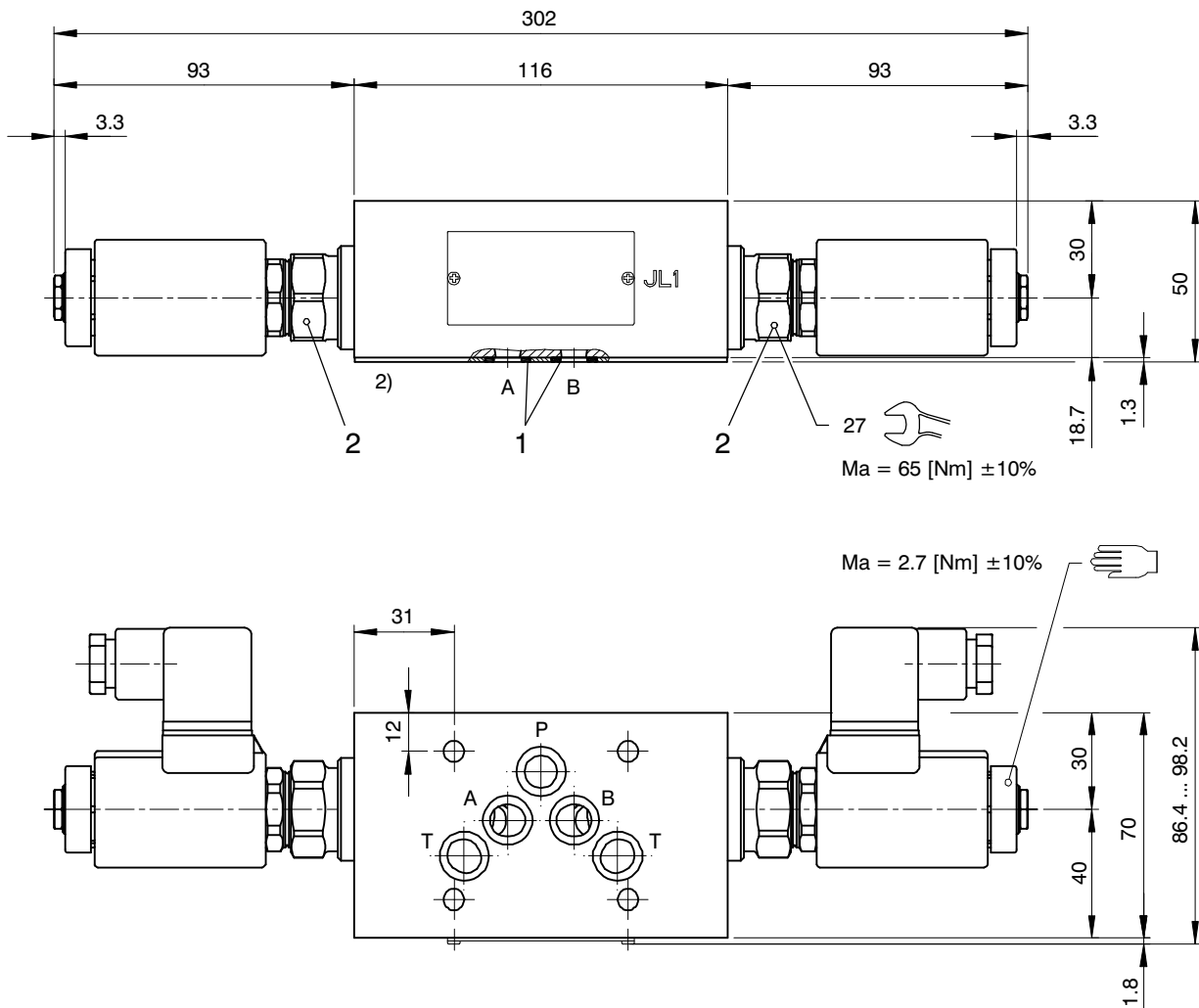

- 1) Valve side
- 2) Connections side (manifold side)

5.2 Solenoid operated seat valve, function in A or B (inline model)

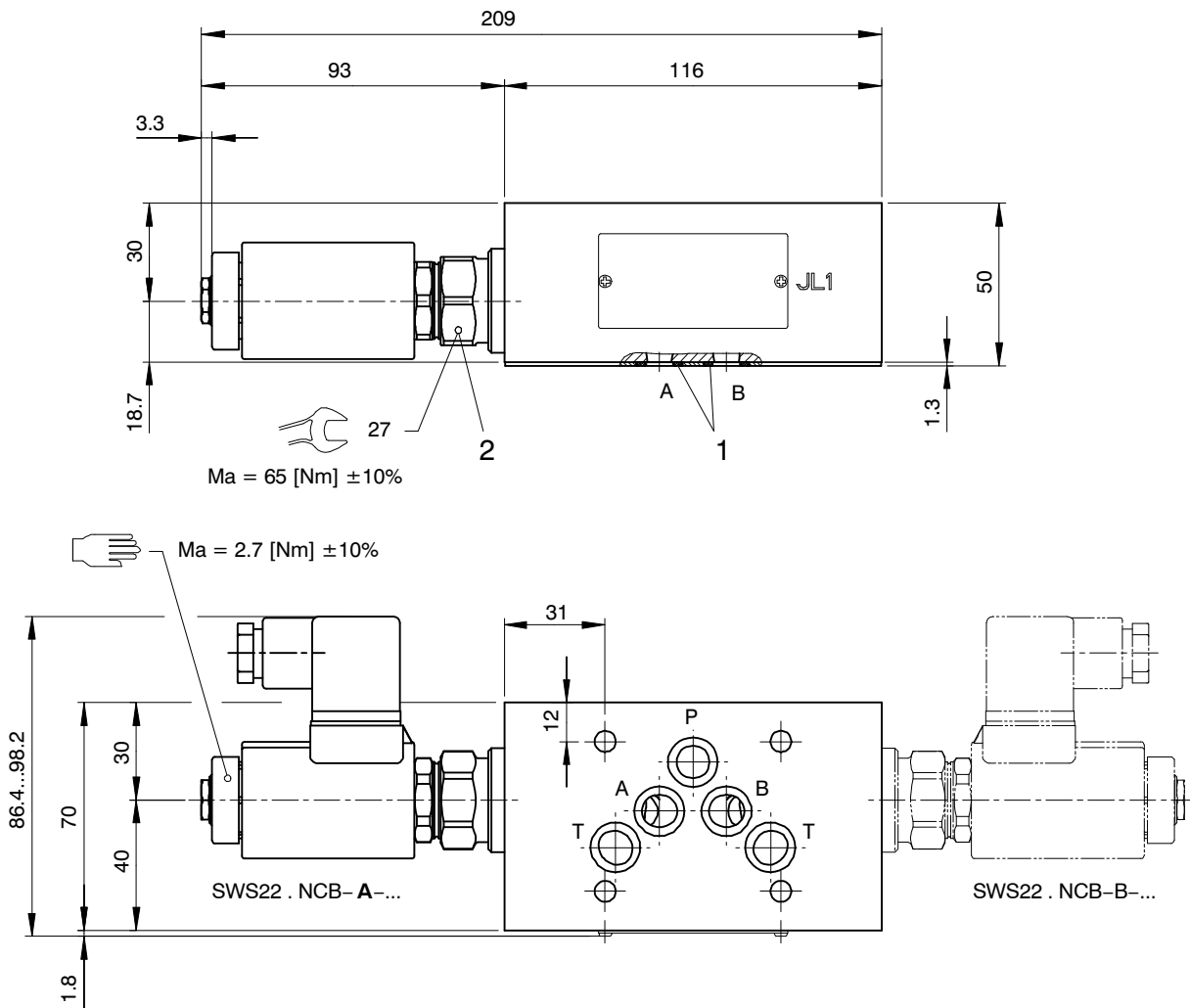

- 1) Valve side
- 2) Connections side (manifold side)

6 Installation information



IMPORTANT!

When installing the valve, make sure that the mating face (the manifold interface) aligns with the valve interface. Do not confuse the sandwich valve's manifold side and directional-valve side. No adjustments are necessary, since the cartridges are set in the factory.



ATTENTION!

Only qualified personnel with mechanical skills may carry out any maintenance work. Generally, the only work that should ever be undertaken is to check, and possibly replace, the seals. When changing seals, oil or grease the new seals thoroughly before fitting them.

NBR seal kit no. DS-316-N ³⁾

Item	Qty.	Description
1	5	O-ring no. 014 \varnothing 12,42 x 1,78 N90
2	2	NBR seal kit no. DS-281-N for 2/2 cartridge seat valve, type WS22G.../ WS22O...-10



IMPORTANT!

³⁾ Seal kit with FKM (Viton) seals, no. DS-316-V

7 Ordering code

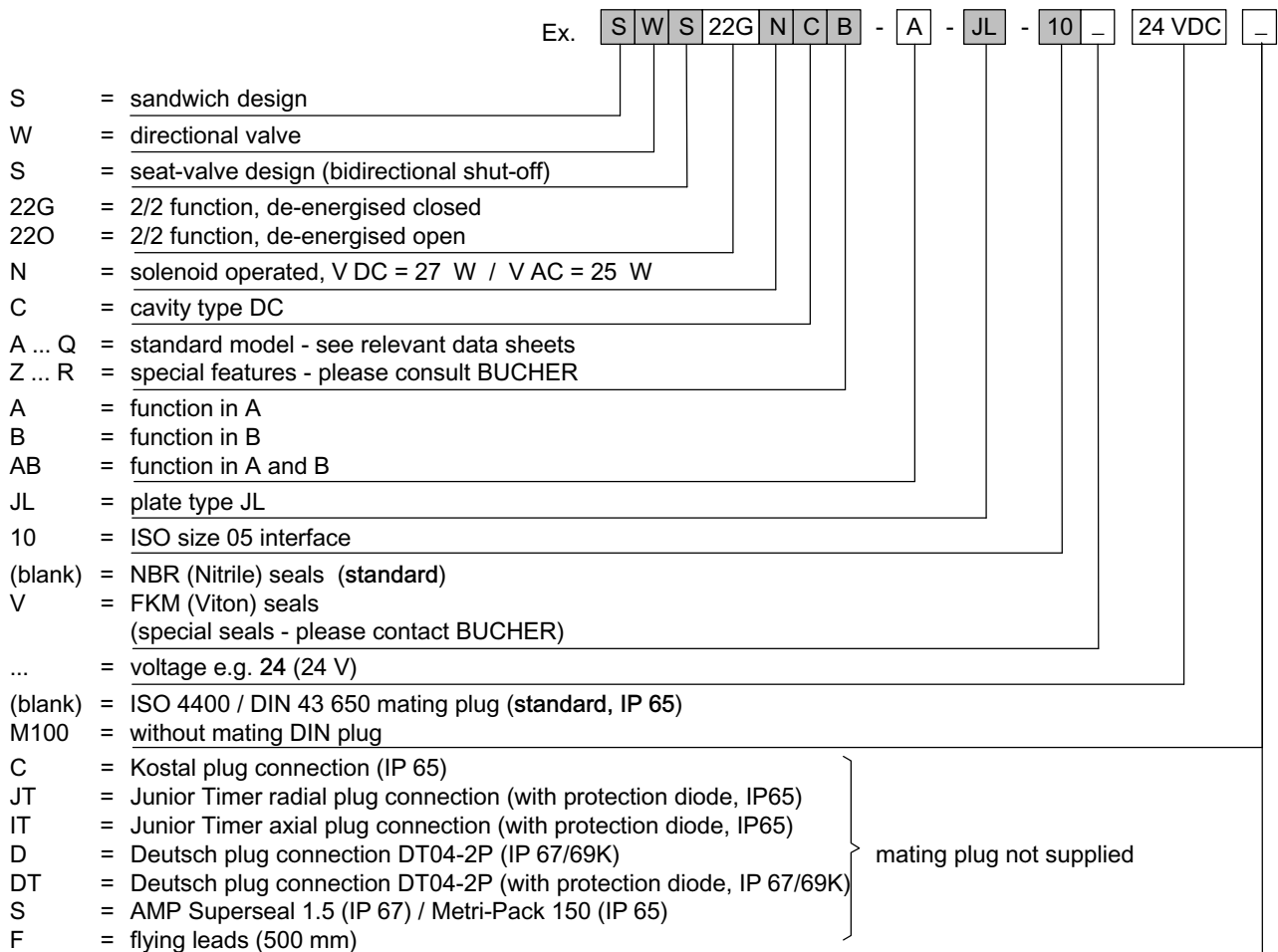

8 Related data sheets

Reference	(Old no.)	Description
400-P-050101	(i-41)	Size 05 interface to ISO 4401-05-04
400-P-120110	(W-2.141)	Coils for screw-in cartridge valves
400-P-131101		2/2 cartridge seat valve, size 10, series WS22G.../ WS22O...

info.ch@bucherhydraulics.com

www.bucherhydraulics.com

© 2015 by Bucher Hydraulics AG Frutigen, CH-3714 Frutigen

All rights reserved.

Data is provided for the purpose of product description only, and must not be construed as warranted characteristics in the legal sense. The information does not relieve users from the duty of conducting their own evaluations and tests. Because the products are subject to continual improvement, we reserve the right to amend the product specifications contained in this catalogue.

Classification: 430.300. - .330.320.300