

DATA SHEET - OPERATION MANUAL

APPLICATION

The unloading valve type **UZOP6**... is used in the hydraulic systems with a pump and a hydraulic accumulator (or the second pump). The valve is used to unload the pump flow (to the drain line) when the pressure in the accumulator reaches the value set at the unloading valve. When pressure in the accumulator drops (by relative theoretical value **30%**) the valve reconnects the pump with accumulator feeding line.



DESCRIPTION OF OPERATION

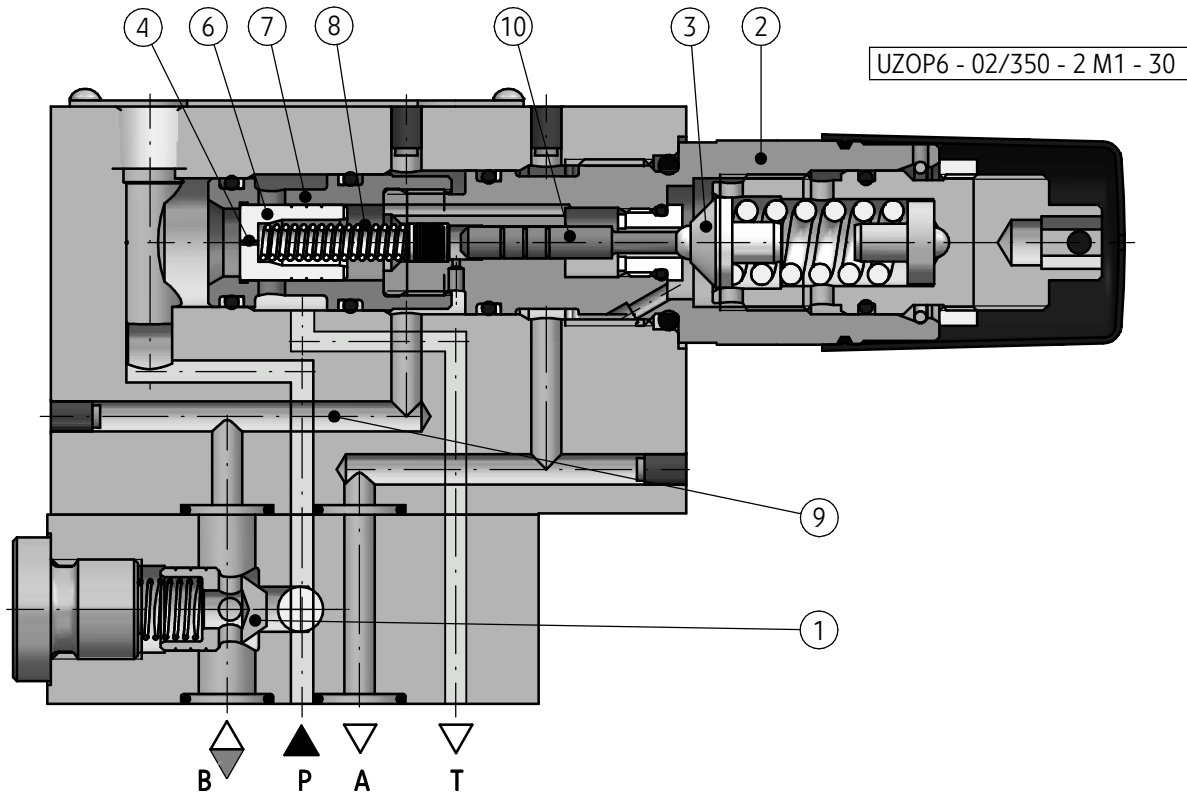

Hydraulic fluid flows from the pump by port **P** through the check valve (1) into port **B** (accumulator system supply). When the pressure set at pilot valve (2) is reached, the poppet (3) lifts and the fluid flows from port **P** through a nozzle (4) to the pilot oil drain **A**. As a result of pressure differences acting on the spool (6) of the main valve (7), the spring is deflected (8) and the connection from port **P** to **T** opens. Then the check valve (1) closes and pressure in port **B** is not relieved to port **T**. As soon as the pilot valve (2) is opened, pressure in port **B** via pilot line (9) acting on the tappet (10)

supports the poppet (3). In consequence after opening the main valve (7) and relieving of port **P**, the poppet (3) is still held in the open position. The pilot valve (2) is reclosed just after the pressure in port **B** drops by the fixed percentage value (**30%**). As a result the pilot oil flowing through the nozzle (4) is blocked and the spool (6) of the main valve (7) closes the flow to drain **T**. The valve reaches the initial position to enable flow from **P** to **B** port through the check valve (1) (accumulator system supply).

TECHNICAL DATA

Hydraulic fluid	mineral oil	
Required fluid cleanliness class	ISO 4406 class 20/18/15	
Nominal fluid viscosity	37 mm ² /s at temperature 55 °C	
Viscosity range	2,8 up to 380 mm ² /s	
Fluid temperature range (in a tank)	recommended	40 °C do 55 °C
	max	-20 °C do +70 °C
Ambient temperature range	- 20 °C do +70 °C	
Maximum operating pressure	35 MPa	
Minimum set pressure	0,7 MPa	
Maximum set pressure	35 MPa	
Maximum flow rate	60 dm ³ /min	
Weight	without check valve ~1,7 kg	with check valve ~ 2,2 kg
Switching hysteresis	30 %	
Switching hysteresis range depending on the pressure and the set range	20 % up to 40 %	

INSTALLATION AND OPERATION REQUIREMENTS

1. Only fully functional and operational valve must be used.
2. During the period of operation the fluid viscosity acc. to requirements defined in this Data Sheet - Operation Manual must be kept.
3. In order to ensure failure free and safe operation the following must be checked on regular basis:
 - proper working of the valve
 - cleanliness of the hydraulic fluid
4. Due to heating of the valve housing to high temp., the valve shall be placed in such way to eliminate the risk of accidental contact with the housing during operation, or to apply suitable covers acc. to European standards PN - EN ISO 13732 - 1 and PN - EN ISO 4413.
5. In order to ensure tightness of the valve connection to the hydraulic system, the dimensions of sealing rings, tightening torques values and valve operation parameters, specified in this Data Sheet - Operation Manual shall be obeyed.
6. A person that operates the valve must be thoroughly familiar with this Data Sheet - Operation Manual.

DIAGRAMS

Graphical symbol of the valve type UZOP6...

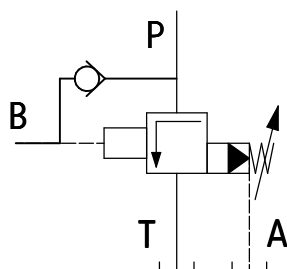

OVERALL AND CONNECTION DIMENSIONS

version UZOP6...Z...

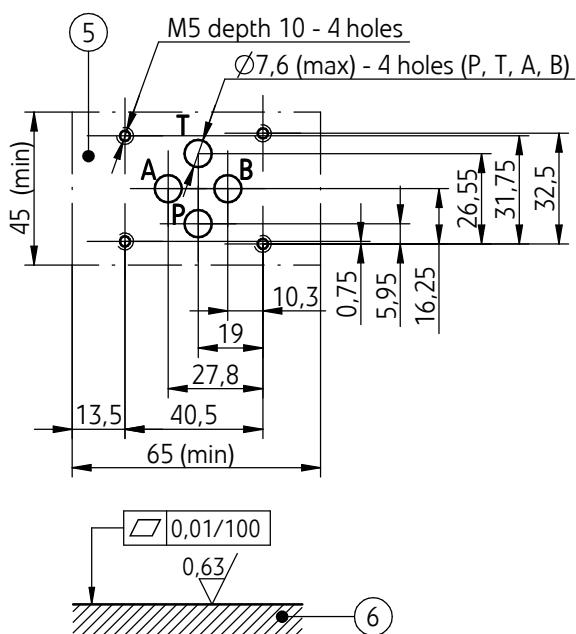
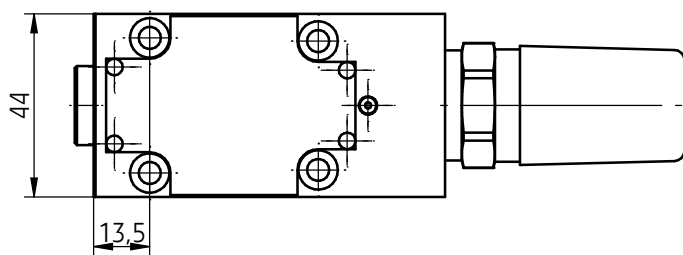
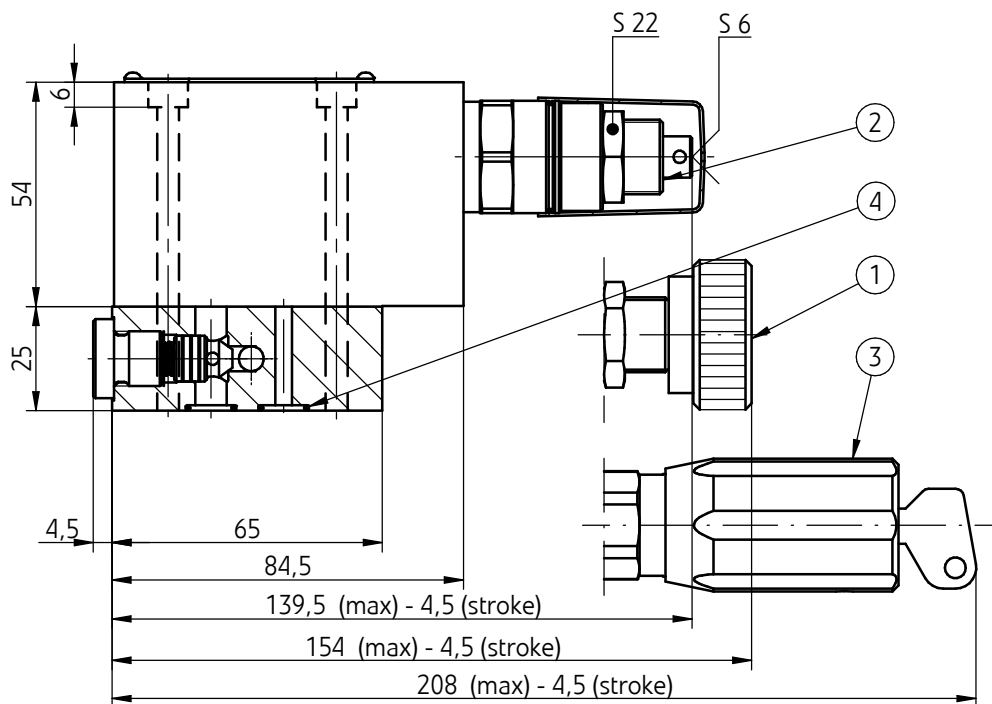

- 1 - Adjustment **1** (hand knob)
- 2 - Adjustment **2** (set screw with hexagon socket **S6**)
- 3 - Adjustment **3** (lockable hand knob)
- 4 - Sealing ring **o-ring 9,2 x 1,8** - pcs 4/set (P, T, A, B)
- 5 - Porting pattern of the subplate surface compliant with **ISO 4401** standard designation **ISO 4401- 03-02-0-94** (CETOP 03); fixing screws **M5 x 85 -10.9** acc. to **PN - EN ISO 4762** pcs 4/set; tightening torque **Md = 9 Nm**
- 6 - Subplate surface required

PERFORMANCE CURVES

measured at viscosity $\nu = 41 \text{ mm}^2/\text{s}$ and temperature $t = 50^\circ\text{C}$

Flow resistance curves through the valve in the cavity

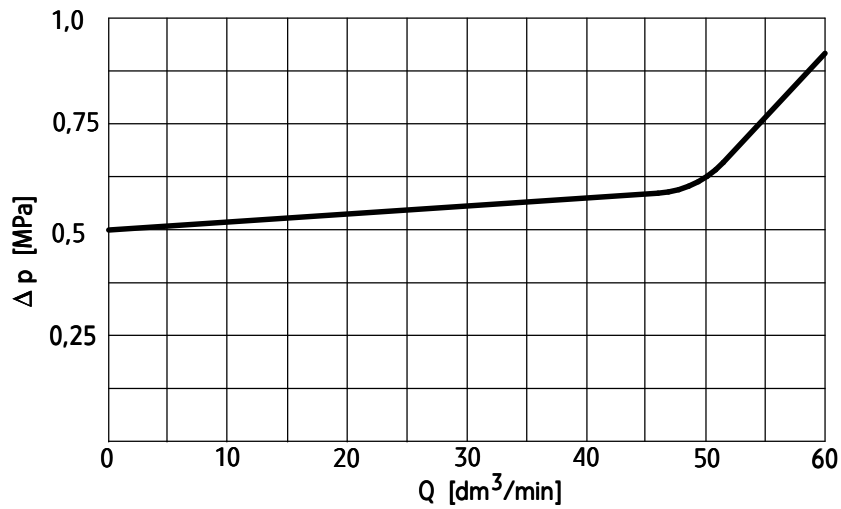

HOW TO ORDER

UZOP	6 +	/	+	M1 -		*
-------------	------------	---	---	-------------	--	----------

Nominal size (NS)

NS6 = **6**

Series number

(02 - 09) - connection and installation dimensions unchanged

series 02 = **02**

Check valve

without check valve = no designation

with check valve = **Z**

Settable pressure range

up to 5 MPa (recommended from 0,7 to 5 MPa) = 50
 up to 10 MPa (recommended from 4 to 10 MPa) = 100
 up to **20 MPa** (recommended from 9 to 20 MPa) = **200**
 up to 35 MPa (recommended from 18 to 35 MPa) = 350

Adjustment element

hand knob = 1
 set screw with hexagon socket = **2**
 lockable hand knob = 3

Percentage value difference between disconnecting and connecting pressure

30% = **30**

Sealing

NBR (for fluids on mineral base) = **no designation**

FKM (for fluids on phosphate ester base) = V

Further requirements in clear text

(to be agreed with the manufacturer)

NOTES:

The valve should be ordered according to the above coding.

The symbols in bold are the preferred versions available in short delivery time.

Coding example: UZOP6 - 02/200 - 2 M1 - 30

EXAMPLE OF APPLICATION IN HYDRAULIC SYSTEM

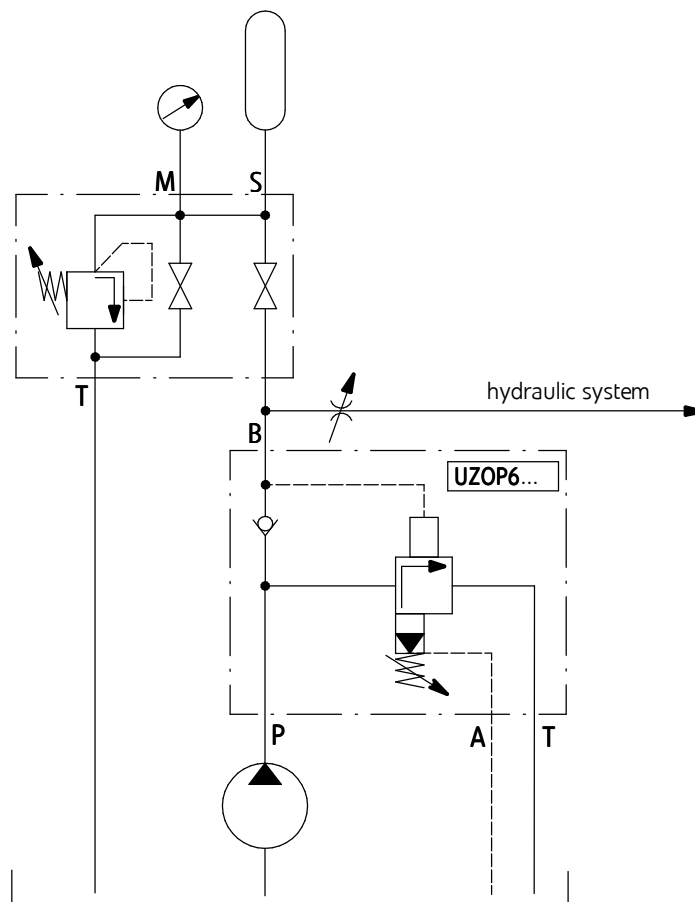

NOTES:

The connection between the unloading valve type **UZOP6...** and the hydraulic accumulator should be as short as possible and with low pressure resistance.
Port **A** must be drained directly to the tank.

PONAR Wadowice S.A.
ul. Wojska Polskiego 29
34-100 Wadowice
tel. +48 33 488 21 00
fax. +48 33 488 21 03
www.ponar-wadowice.pl

