

2/2 ... 4/4 Directional Seat Valve, ISO Size 03

$Q_{\max} = 20 \text{ l/min}$, $p_{\max} = 315 \text{ bar}$

Bidirectional seat-valve shut-off, direct acting, pneumatic operation

Series W2N..., W2P...

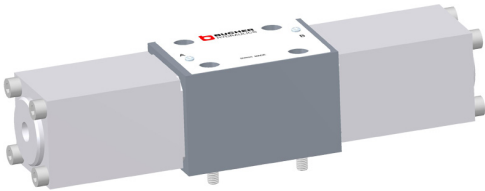

- With cartridge valve, type W1...
- Interface to ISO 4401-03-02
- Bidirectional seat-valve shut-off or flow
- Version with closed crossover (overlap)
- Control head with G1/8" threaded port
- With optional push-in check valve or orifice
- Control head is hard-anodised aluminium

1 Description

The W2N... / W2P... series of 2/2 ... 4/4 pneumatic operation directional seat valves are direct acting, pressure balanced, manifold-mounting valves with a size 03 interface to ISO 4401-03-02. The main components of the valves are a manifold-mounting body and the push-in 2/2 or 3/2 directional seat valve cartridge (type W1...). Dependent on the operating position, the ports are either closed with virtually zero leakage, or open and flow is possible in either direction. The "overlapped" model (W2P...) features a closed crossover characteristic i.e. during the valve's switching period, there is no connection between the ports and therefore only a minimal loss of flow/pressure occurs. For applications where

a check valve or an orifice in the P port is necessary, either of these features can be included as an option. These hand operated seat valves are predominantly used in certain mobile and industrial applications where leak-tight shut-off functions are crucially important. Examples are where loads, tensions, or clamping forces must be held without leakage. The manifold-mounting body is phosphated. The external parts of the cartridge are zinc plated (CrVI-free), the aluminium control head is hard anodised, and the valve is thus suitable for use in the harshest operating environments.

2 Technical data

General characteristics	Description, value, unit
Designation	2/2, 3/2, 3/3, 4/3 or 4/4 pneumatically operated directional seat valve
Design	manifold-mounting, bidirectional seat-valve shut-off, direct acting poppet and valve-spool design (pressure balanced) with underlapped or overlapped spool
Mounting method	4 x $\varnothing 5,5$ holes for M5x30 cap screws
Tightening torque	5.2 Nm \pm 10%
Size	size 03 interface to ISO 4401-03-02 / DIN 24 340 A6
Weight	1.45 kg (2/2 ... 3/2 models) 1.90 kg (3/3 ... 4/4 models)
Mounting attitude	unrestricted
Ambient temperature range	-25 °C ... +80 °C

Hydraulic characteristics	Description, value, unit
Maximum operating pressure	...315 bar
Maximum flow rate	20 l/min 10 l/min (series W2P..., with closed crossover)
Flow direction	see symbols, table on page 3
Hydraulic fluid	HL and HLP mineral oil to DIN 51 524; for other fluids, please contact BUCHER
Hydraulic fluid temperature range	-25 °C ... +80 °C
Viscosity range	10...650 mm ² /s (cSt), recommended 15...250 mm ² /s (cSt)
Minimum fluid cleanliness Cleanliness class to ISO 4406 : 1999	class 20/18/15

Pneumatische Kenngrößen	Description, value, unit
Minimaler Steuerdruck	6.5 bar

3 Performance graphs



IMPORTANT!

Detailed performance data and other hydraulic characteristics can be found in the data sheet for the respective 2/2 or 3/2 hand operated cartridge seat valve (series W1...) that is fitted. See "Related data sheets".



ATTENTION!

The performance figures in the data sheet for the cartridge valve refer just to the cartridge itself. Take into account the additional pressure drop in the body into which it is fitted.

$\Delta p = f(Q)$ Pressure drop - Flow rate characteristic through orifice (metering function)

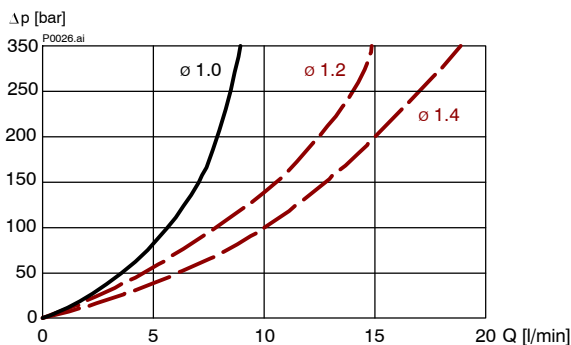

∅ 1.2 and ∅ 1.4 orifices drilled out by customer!

$\Delta p = f(Q)$ Pressure drop - Flow rate characteristic through push-in check valve

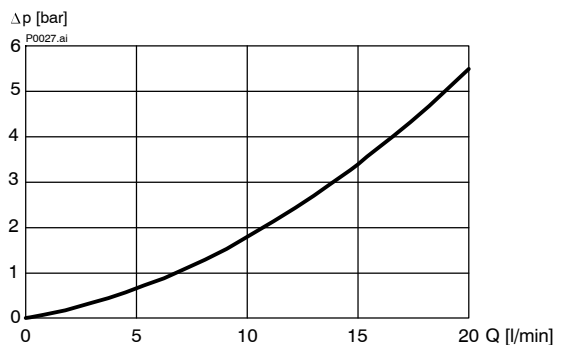

Code	Symbols	Remarks	Operating principle
2-way circuit (with 2/2 cartridge seat valve)	22 S 	For 2/2 circuits, the customer must plug the T port!	
	22 O 		
3-way circuit (with 3/2 cartridge seat valve)	32 S 	For 2/2 circuits, the customer must plug the T port!	
	32 O 		
33 R 	To achieve the 4th valve function (the shaded box), actuate the two control head a and b simultaneously!		
43 F 		To achieve the 4th valve function (the shaded box), actuate the two control head a and b simultaneously!	
44 A 	To achieve the 4th valve function (the shaded box), actuate the two control head a and b simultaneously!		

4 Dimensions & sectional view

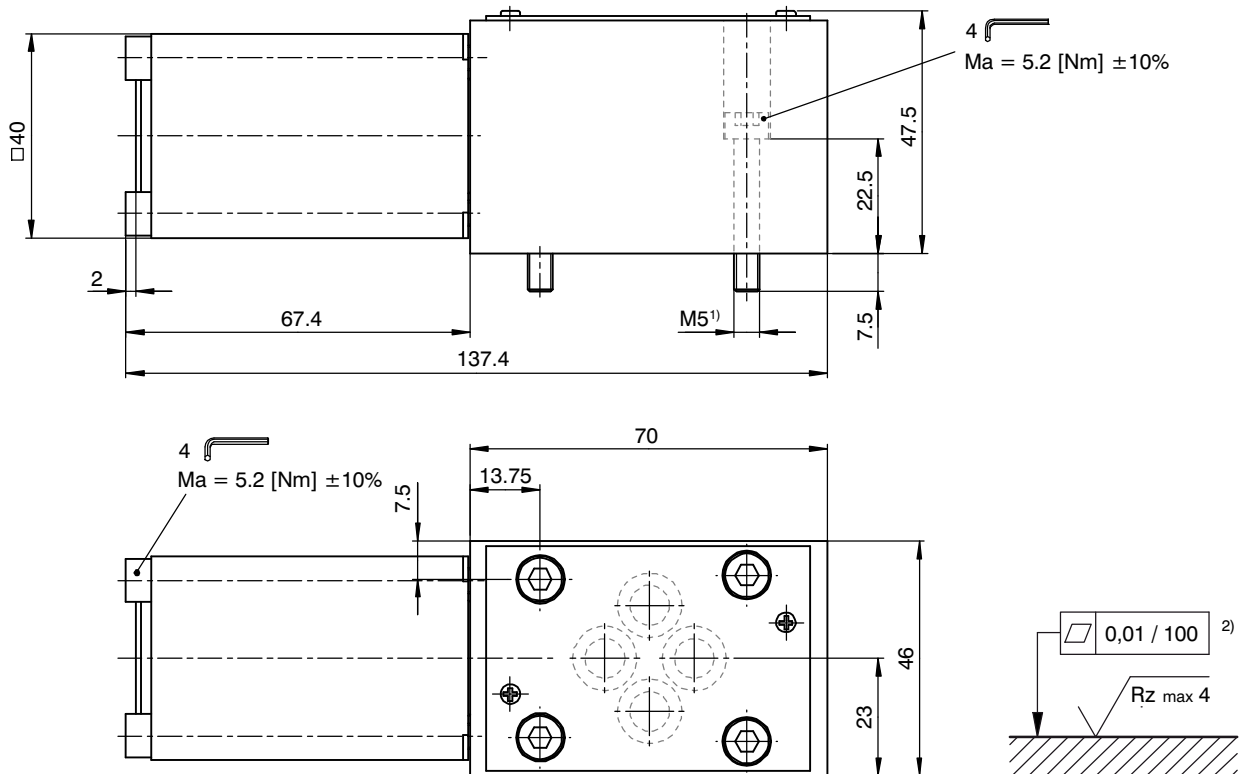

2/2 and 3/2 hand operated directional seat valve (single-control head model)

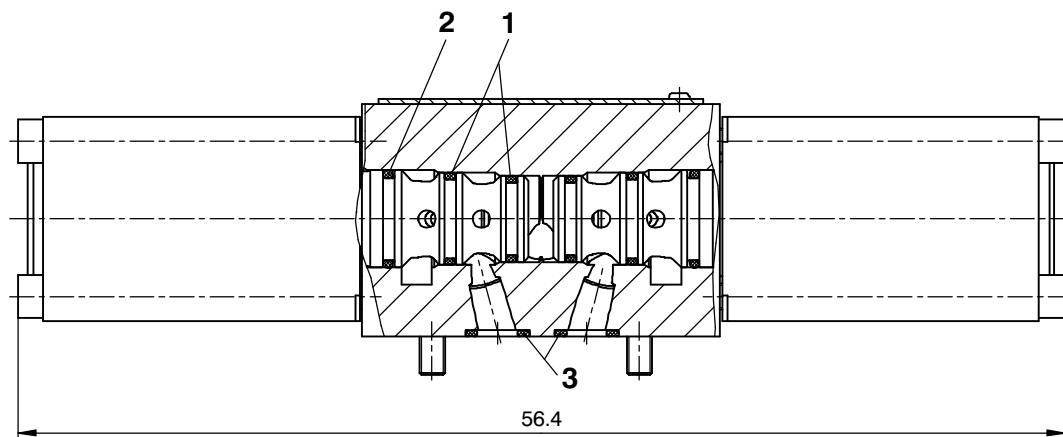

3/3, 4/3, and 4/4 hand operated directional seat valve (double-control model)

Seal kit NBR no. DS-388-N ³⁾

Item	Qty.	Description
1	4	O-ring no. 015 \varnothing 14,00 x 1,78 N90
2	2	O-ring no. 016 \varnothing 15,60 x 1,78 N90
3	4	O-ring no. 012 \varnothing 9,25 x 1,78 N90



IMPORTANT!

- 1) Valve mounting bolts M5x30 (included in the delivery)
- 2) Required surface finish on the mounting face (valve pad)
- 3) Seal kit with FKM (Viton) seals, no. DS-388-V

5 Options

5.1 Push-in check valve

To prevent uncontrolled back-pressure effects or back-flow of oil, series W2N... / W2P... hand operated directional seat valves can be supplied with an optional push-in check valve, type RCA-5, and a special body. The check valve allows free flow from P to A or B, but prevents flow in the opposite direction, with no leakage.

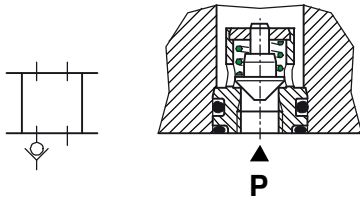

Application: when several valves are supplied in parallel, for instance, and the supply pressure in P drops below the pressure in A or B (another circuit is vented, or a lightly-loaded actuator is operated). The pressure in service line A or B is then higher, but the check valve prevents it from falling during such operations in other circuits.

5.2 Orifice (metering function)

An orifice disc (type D10, \varnothing 1.0 mm) must be used when, as a consequence of the operating conditions that exist, circuit operations may result in flow rates that exceed the performance limit of the valve.



IMPORTANT!

The orifice disc fitted for this purpose is \varnothing 1.0 mm. Customers may drill it out to \varnothing 1.4 mm maximum (see performance graphs).

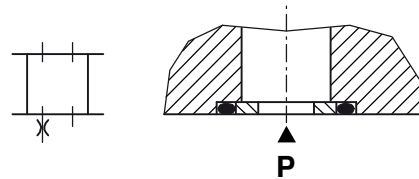

Application: when used for charging accumulators, for instance, or when the hand operated directional seat valves are used to pilot other valves.

6 Installation information



ATTENTION!

Only qualified personnel with mechanical skills may carry out any maintenance work. Generally, the only work that should ever be undertaken is to check, and possibly replace, the seals. When changing seals, oil or grease the new seals thoroughly before fitting them.



IMPORTANT!

When fitting the valves, use the specified tightening torque for the mounting bolts. No adjustments are necessary, since the cartridges are set in the factory.

7 Ordering code

Ex.

W2	N	32S	N	6	R	A	D	_
----	---	-----	---	---	---	---	---	---

- W2 = directional seat valve, manifold mtg.
- N = open crossover (standard)
- P = closed crossover, (only possible with 3/2, 4/3, and 4/4 functions)
- 22 S = 2/2 function, P closed
- 22 O = 2/2 function, P ↔ A connected
- 32 S = 3/2 function, P closed
- 32 O = 3/2 function, P ↔ A connected
- 33 R = 3/3 function, P, A and T closed
- 43 F = 4/3 function, P ↔ A ↔ B connected
- 43 G = 4/3 function, A ↔ B ↔ T connected
- 44 A = 4/4 function, P ↔ A and B ↔ T connected
- N = without push-in check valve or orifice (standard)
- R = with push-in check valve, type RCA-5 (in P port)
- D10 = with orifice disc, type D10 (in P port)
- 6 = ISO size 03 interface
- Q = 2/2 and 3/3 function, pneumatic operation
- R = 3/2, 4/3 and 4/4 function, pneumatic operation
- S = 3/2, 4/3 and 4/4 function, pneumatic operation, with closed crossover
- A ... Q = standard model - see relevant data sheets
- Z ... R = special features - please consult BUCHER
- D = nitrile seals (standard)
- I = viton seals
- 1 ... 9 = design number, seat valve (omit when ordering new units)

8 Related data sheets

Reference	(Old no.)	Description
400-P-010301	(i-01)	Orifice flow chart
400-P-030501	(i-31)	Size 03 interface to ISO 4401-03-02
400-P-110410		2/2 cartridge seat valve, series W1Q..., size 6
400-P-110415		3/2 cartridge seat valve, series W1R.../W1S..., size 6

info.ch@bucherhydraulics.com

www.bucherhydraulics.com

© 2015 by Bucher Hydraulics AG Frutigen, CH-3714 Frutigen

All rights reserved.

Data is provided for the purpose of product description only, and must not be construed as warranted characteristics in the legal sense. The information does not relieve users from the duty of conducting their own evaluations and tests. Because the products are subject to continual improvement, we reserve the right to amend the product specifications contained in this catalogue.

Classification: 430.300.-.315.315.340