

Pressure Reducing Cartridge, 10 mm Solenoid Controlled, Two stage Spool Valve Design for HTF Cavity Type DD Series WDRVPB-5...

D - 6.35

Issue 06.98

10 mm nom.
p max. 315 [bar]
Q max. 120 [l/min]

- Two-pressure valve, ON / OFF or HI / LO
- External pilot drain via port Z
- Coils can be changed without opening the hydraulic envelope
- Very good price/performance ratio
- Available in line mounting body DD-12 (G 1/2")
- Available in wide range of ISO/CETOP 3 and 5 stacking functions

DIMENSIONS

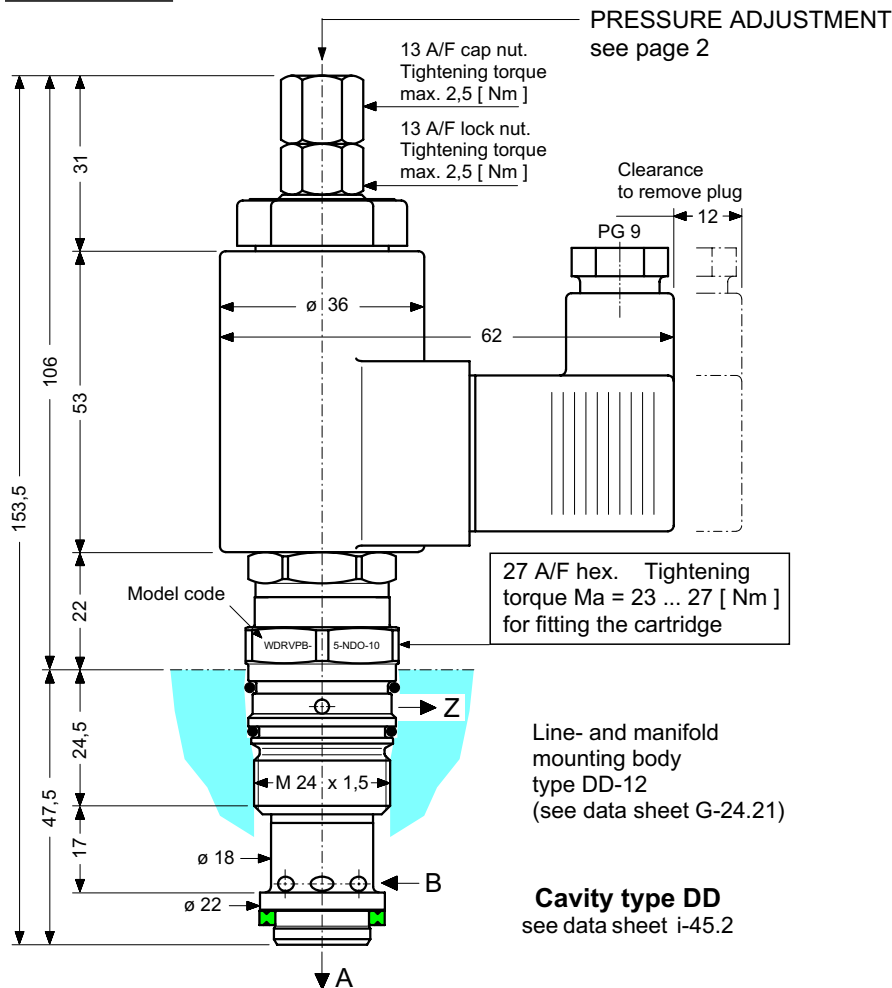

SYMBOL

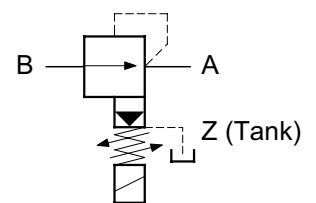

W DRVPB-5..DO-10 ...

DESCRIPTION

Series WDRVPB-5 ... -10 valves are 10 mm solenoid controlled screw-in pressure reducing cartridge valves for HTF cavity type DD. They replace the WDRVP-5-10 series of valves shown on data sheet D-6.4c.

They are of two-stage design, with a seated pilot stage and a sliding spool main stage.

Using only the external adjustment, a higher reduced pressure p₁ and a lower reduced pressure p₂ can be adjusted smoothly and independently of each other, and either pressure can be activated.

When the pilot stage is active (solenoid energised = pressure reducing function), pilot control oil is drained within the valve to the Z port.

Form tools are available for sale or hire, should customers wish to manufacture their own blocks or subplates.

For direct pipe-mounted applications, the line- and manifold mounting body type DD-12 (G 1/2") can be used.

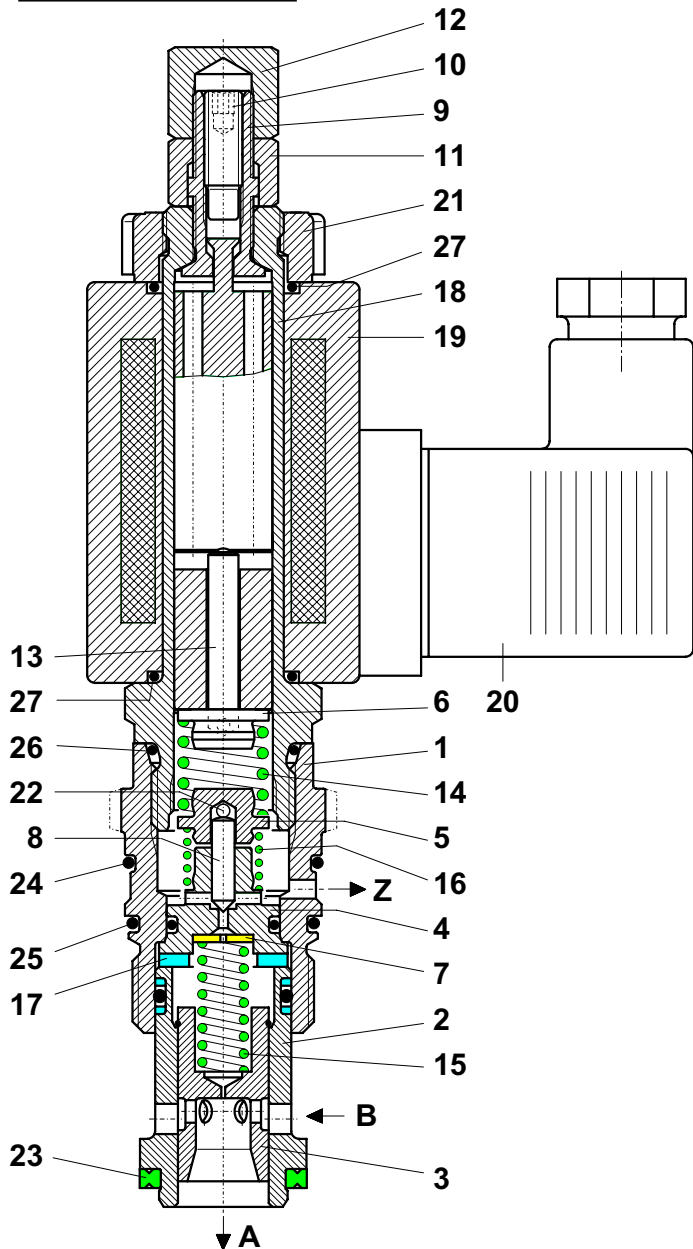

▲ = available as service part
 *) = part of seal kit no. DS-261

It.	Qty.	Description	
1	1	Cartridge head	∅ 30 x 38,3
2	1	Cartridge neck	∅ 21,9 x 30,5
3	1	Spool	∅ 12 x 23
4	1	Valve seat complete	∅ 17 x 14
5	1	Spring cap	∅ 12 x 7,2
6	1	Spring cap	∅ 12 x 6,8
7	1	Orifice disc	∅ 8,8 / 0,6 x 1
8	1	Valve cone	∅ 2,99 x 12,18
9	1	Adjusting screw	∅ 11 x 24,5
10	1	Adjusting screw	M5 x 0,5 x 19
11	1	Lock nut	13 A/F x 9
12	1	Cap nut, special	13 A/F x 12
13	1	Push pin	∅ 4 x 24,2
14	1	Spring	2,00 x 12,0 x 12,0 iG = 4,5
15	1	Spring	1,30 x 8,5 x 17,5 iG = 8,0
16	1	Spring	0,63 x 9,26 x 14,0 iG = 5,5
17	1	Disc	∅ 17,2 / 9,5 x 2
18	1	Core tube S25	∅ 26 x 82,5
19	1	Coil	∅ 36 ..VAC / 25 W
		Coil	∅ 36 ..VDC / 27 W
20	1	Square plug, DIN 43 650, with flat seal	
21	1	Hand nut	∅ 30 x 9,2
22	2	Ball	∅ 3 DIN 5401
	1	Seal kit no. DS-261, comprising *):	
23	1*)	Seal	∅ 22,1 / 16,5 x 2,5
24	1*)	O-ring no. 020	∅ 21,95 x 1,78 N90
25	1*)	O-ring	∅ 23 x 1 N90
26	1*)	O-ring no. 017	∅ 17,17 x 1,78 N90
27	2*)	O-ring no. 016	∅ 15,60 x 1,78 N70

TO ORDER SERVICE PARTS, STATE:

- complete unit model code from the nameplate, including the design number
- data sheet number, including issue date
- part item number from above list
- part description from above list
- quantity required

D-6.35

PRESSURE ADJUSTMENT (pressure p1 must be set first, followed by pressure p2)

Setting the higher reduced pressure p1

on series WDRVPB-5-10 ...
 with solenoid energised:

1. Slacken and remove cap nut item 12.
2. Slacken 13 A/F lock nut item 11 approx. 1/2 turn.
3. With pump running **and with the solenoid energised**, use the two flats (7 A/F) to turn adjusting screw item 9 until the required reduced pressure is set in A.
4. Hold the adjusting screw item 9 using the 7 A/F flats while tightening the 13 A/F lock nut item 11.
5. Refit and tighten the cap nut item 12.

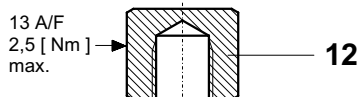

When setting pressure p1, adjusting screw item 9 must not be over-tightened as this can damage the shoulder which limits the maximum pressure setting. As soon as a definite end-stop can be felt, do not turn any further.

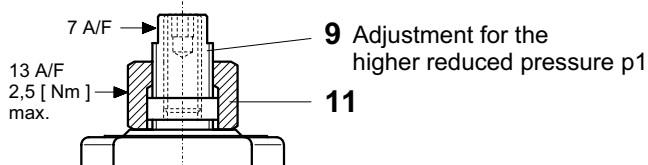

Setting the lower reduced pressure p2

on series WDRVPB-5-10 ...
 with solenoid deenergised:

1. Slacken and remove cap nut item 12.
2. With pump running **and with solenoid deenergised**, use the adjusting screw item 10 (2.5 A/F hex. socket) to set the reduced pressure p2 in A. (p2 min.: 10 ... 25 bar)
3. Refit and tighten the cap nut item 12.

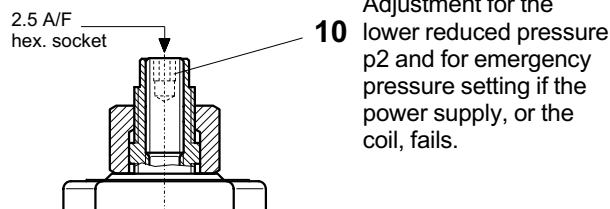
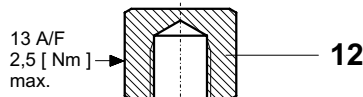

Adjustment for the lower reduced pressure p2 and for emergency pressure setting if the power supply, or the coil, fails.

SUBJECT TO CHANGE WITHOUT NOTICE

INSTALLATION AND SERVICING

MUST BE CARRIED OUT WITH CARE, AND BY QUALIFIED PERSONNEL ONLY.

When changing seals, the new seals should be thoroughly oiled or greased before fitting them to the valve.

Use the correct tightening torque when fitting the cartridge.

After setting the pressures, use the correct torques when tightening the lock nut item 11 and cap nut item 12.

MAIN CHARACTERISTICS

Type	pressure reducing cartridge with two electrically selected pressures
Design	two-stage, seated pilot, spool-type main stage with external pilot drain, solenoid controlled
Mounting method	screw-in cartridge (M 24 x 1,5)
Size	nominal 10 mm, HTF cavity type DD
Mass	0,52 kg
Mounting attitude	unrestricted
Flow direction	B → A (see symbol)
Operating pressure	... 315 bar in A and B
Back pressure	max. 20 bar in Z (Tank)
Pressure adjust. range, p1	pressure range N : 10 ... 315 bar pressure range M : 10 ... 210 bar pressure range L : 10 ... 65 bar
Fluids	hydraulic oils HL and HLP to DIN 51 524 other fluids - contact HTF
Min. fluid cleanliness	18/14 to ISO 4406 / CETOP RP70H 8 ... 9 to NAS 1638
Fluid temperature range	-20° ... +60° C
Viscosity range	10 ... 300 cSt
Flow rate Q max..	0 ... 120 l/min (see performance data)
Standard voltages	115 VAC, 230 VAC 50 ... 60 Hz 12 VDC, 24 VDC
Permissible voltage fluctuation	± 10%
Power consumption	VAC = 25 W / VDC = 27 W
Duty cycle	100% ED
Protection class	IP 65 to DIN 40050
Electrical connector	3-pin square plug to DIN 43 650 / ISO 4400 other connectors - contact HTF

D-6.35

SUBJECT TO CHANGE WITHOUT NOTICE

PERFORMANCE DATA Measured with oil viscosity 33 cSt

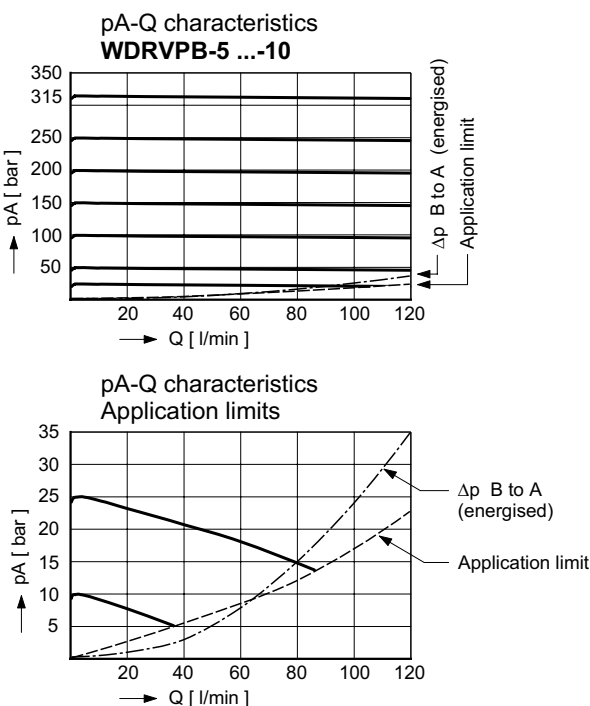

Pilot oil drain flow in Z

WDRVPB-5 ...-10	250 ... 600 cm ³ /min
-----------------	----------------------------------

Switching times: measured with 24 VDC coil, 10% under-voltage and coil at steady-state temperature

	ON	OFF
WDRVPB-5 ...-10	25 ... 150 ms	≤ 50 ms

Switching times are influenced by flow rate, pressure, supply voltage, coil temperature and oil viscosity

MODEL CODE KEY

Ex.



- Solenoid controlled pressure reducing valve _____
- Two-stage _____
- Cartridge design _____
- A ... Q = **standard** model per relevant data sheet } _____
- Z ... R = special features by arrangement } _____
- 5 = pressure control type 5 (pressure reducing) _____
- N = pressure range ... 315 bar (**N**ormal spring) } _____
- M = pressure range ... 210 bar (**M**edium spring) } _____
- L = pressure range ... 65 bar (**L**ight spring) } _____
- D = for HTF cavity type DD _____
- O = deenergised open _____
- 10 = nominal size 10 mm _____
- (blank) = Nitrile seals (**standard**) } _____
- V = Viton seals } _____
- Special seals by arrangement } _____
- 1 ... 9 = design number (omit when ordering new units) _____
- Voltage and current plainly specified _____

Related Data sheets

- i-45.2 HTF cavity type DD
- G-24.21 Line- and manifold mounting body DD-12 (G 1/2")