

## Bypass Hydrostat Cartridge Valve, Size 10 Electrically Controlled, Seated Pilot, Spool-type Main Stage Series WDWVPB-2 ... / WDWVPY-2 ...

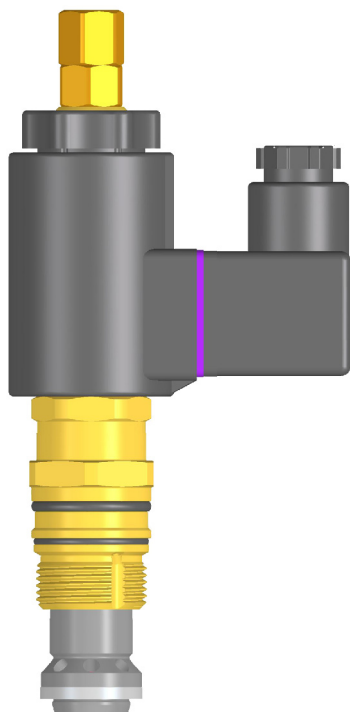

- 140 l/min, 315 bar
- With hydrostat spring:  
8 bar = WDWVPB-2...  
5 bar = WDWVPY-2...
- Integral pressure relief function
- With integral damping orifice in Z line
- Internal pilot oil drain to port B
- Surface protection: Cartridge zinc coated, chromited (Cr VI-free)
- Can be fitted in a line- and manifold mounting body

### 1. Description

The WDWVPB-2... / WDWVPY-2... series of cartridges are electrically controlled, screw-in, bypass hydrostats with an integral pressure relief function. They have a seated pilot stage and a sliding spool-type main stage. The valves can be supplied with either an 8 bar hydrostat spring (WDWVPB-2...) or

a 5 bar spring (WDWVPY-2...). When the Z port is vented, the special (patented) spool configuration enables very small  $\Delta p$  values (smaller than the  $\Delta p$  for hydrostat function) to be achieved during unloaded recirculation. The lowered  $\Delta p$  values result in reduced heating of the oil and correspondingly lower energy costs for the user. Using only the external adjustments, a higher pressure  $p_1$  (relief setting) and a lower pressure  $p_2$  (a second relief setting or, alternatively, unload) can be adjusted smoothly and independently, and either pressure can be activated. For customers who manufacture their own manifold blocks, we offer form-tool sets for sale or hire. Use the DDY-12 body with threaded ports (G1/2") for line- and manifold mounting applications.

### 2. Symbol

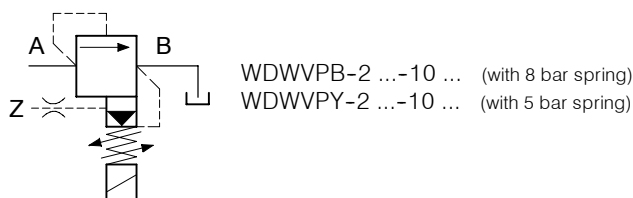

### 3. Main characteristics

Designation		bypass hydrostat cartridge valve
Design		seated pilot, spool-type main stage with remote control port Z
Mounting method		screw-in cartridge M24 x 1.5
Size		nominal size 10 mm, cavity type DD
Weight	kg	0.52
Mounting attitude		unrestricted
Flow direction		A → B, see symbol
Operating pressure range	bar	... 315
Pressure-setting range	bar	pressure range N = ... 315 pressure range M = ... 210 pressure range L = ... 65
Flow rate $Q_{max}$	l/min	140, see performance graphs
Hydraulic fluid		HL and HLP hydraulic oils to DIN 51 524; for other fluids, please consult BUCHER
Fluid temperature range	°C	-25 ... +80
Ambient temperature	°C	-25 ... +50

Viscosity range	mm <sup>2</sup> /s (cSt)	10 ... 500 recommended 15 ... 250
Minimum fluid cleanliness level		20/18/15 to ISO 4406 : 1999
Nominal voltages	VAC VDC	115, 230, (50...60 Hz) 12, 24
Nominal voltage tolerance	%	± 10
Nominal power consumption	W	VAC = 25, VDC = 27
Relative duty cycle	% ED	100
Protection class to EN 60 529		IP 65 / IP 67, see "Ordering code" (when connector plugs are properly fitted)
Electrical connection		3-pin square plug to ISO 4400 / DIN 43 650 (standard) for other connectors, see "Ordering code"

## 4. Performance graphs

measured with oil viscosity 33 mm<sup>2</sup>/s (cSt), coil at steady-state temperature and 10 % undervoltage

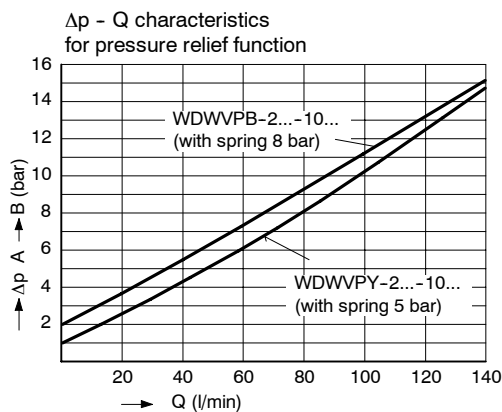
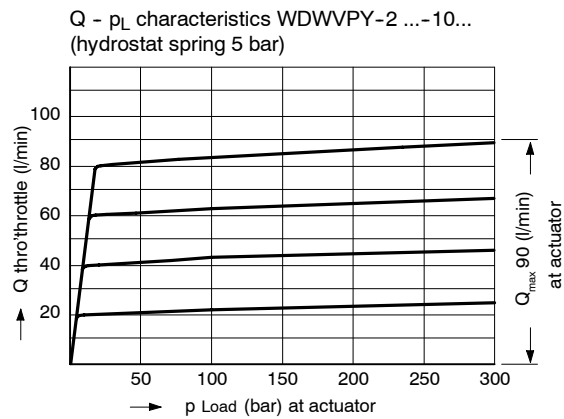
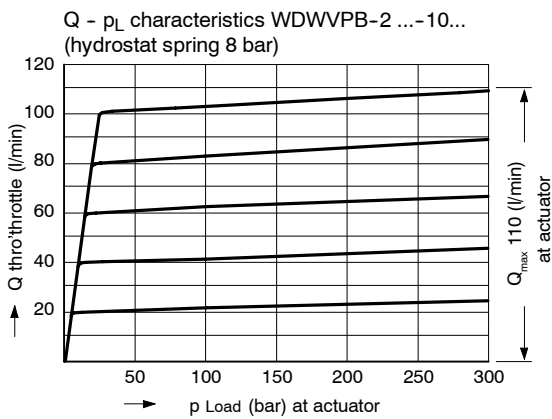
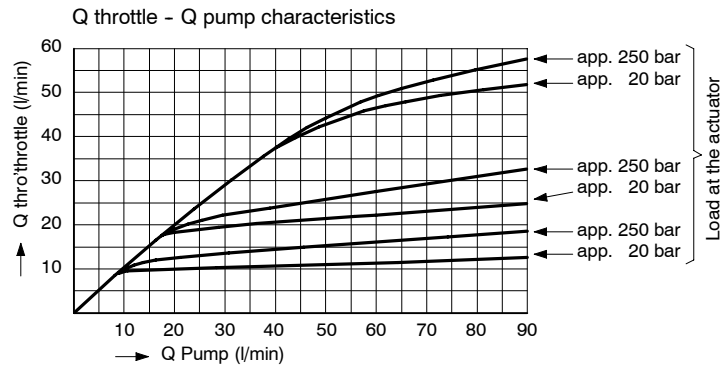
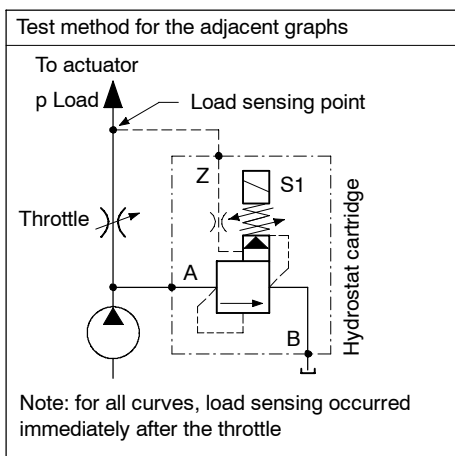

## 5. Pressure adjustment

(pressure p1 must be set first, followed by pressure p2)

Setting the **higher pressure p1** on series WDWVPB ... / WDWVPY ... as the higher working pressure with **solenoid energised**:

1. Slacken and remove cap nut item 12 (13 A/F).
2. Slacken lock nut item 11 (13 A/F) approx. 1/2 turn.
3. With pump running and with the solenoid energised, use the two flats (7 A/F) to turn adjusting screw item 9 until the required pressure is set in A.
4. Hold the adjusting screw item 9 using the 7 A/F flats while tightening the lock nut item 11 (13 A/F).
5. Refit and tighten the cap nut item 12.

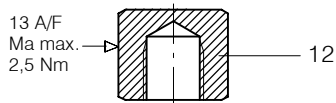

When setting pressure p1, adjusting screw item 9 must not be over-tightened as this can damage the shoulder which limits the maximum pressure setting. As soon as a definite end-stop can be felt, do not turn any further.

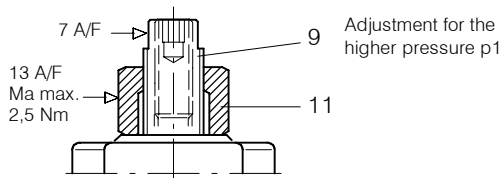

Setting the **lower pressure p2** on series WDWVPB ... / WDWVPY ... (a second pressure or, alternatively, unload) with **solenoid deenergised**:

1. Slacken and remove cap nut item 12 (13 A/F).
2. With pump running and with the solenoid deenergised, use the adjusting screw item 10 (2.5 A/F hex. socket) to set the pressure p2 in A. (p2 min: 2 ... 15 bar for WDWVPB, dependent on flow) (p2 min: 1 ... 14 bar for WDWVPY, dependent on flow)
3. Refit and tighten the cap nut item 12.

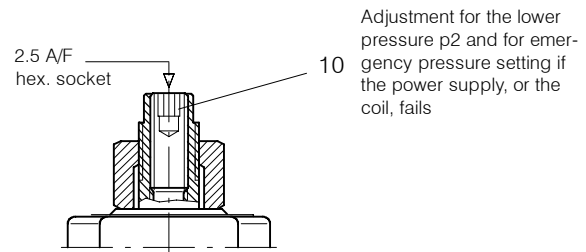
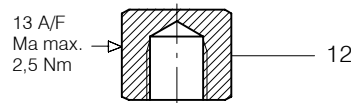

Adjustment for the lower pressure p2 and for emergency pressure setting if the power supply, or the coil, fails

## 6. Application example

### Conventional circuit

6 elements  
6 cavities

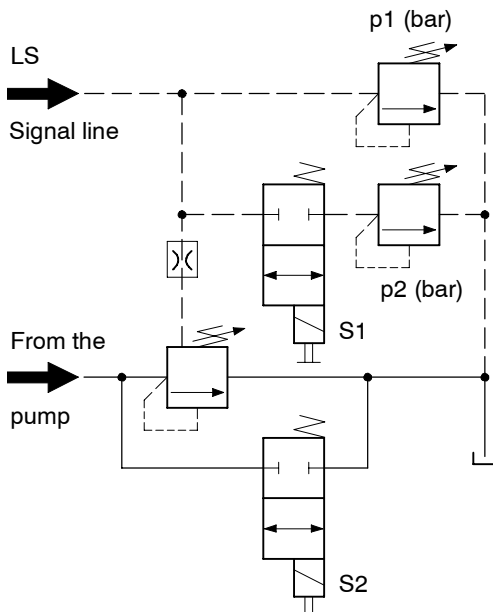

### Bucher hydraulics solution

1 element  
1 cavity

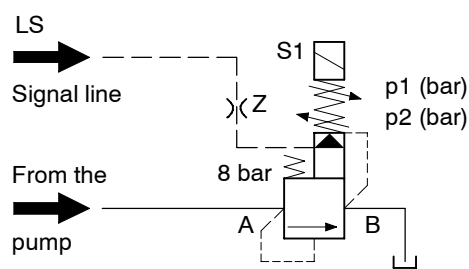

### WDWVPB-2...-10...

$Q_{max}$  140 l/min  
 $p_{max}$  315 bar

- LS - control  $\Delta p$  = 8 bar
- Unloaded pressure (LS vented):  
 $\Delta p$  app. 6 bar at  $Q = 50$  l/min
- S1 energised = pressure p1
- S1 deenergised = pressure p2

### WDWVPY-2...-10...

$Q_{max}$  140 l/min  
 $p_{max}$  315 bar

- LS - control  $\Delta p$  = 5 bar
- Unloaded pressure (LS vented):  
 $\Delta p$  app. 5 bar at  $Q = 50$  l/min
- S1 energised = pressure p1
- S1 deenergised = pressure p2

**7. Dimensions and sectional view**

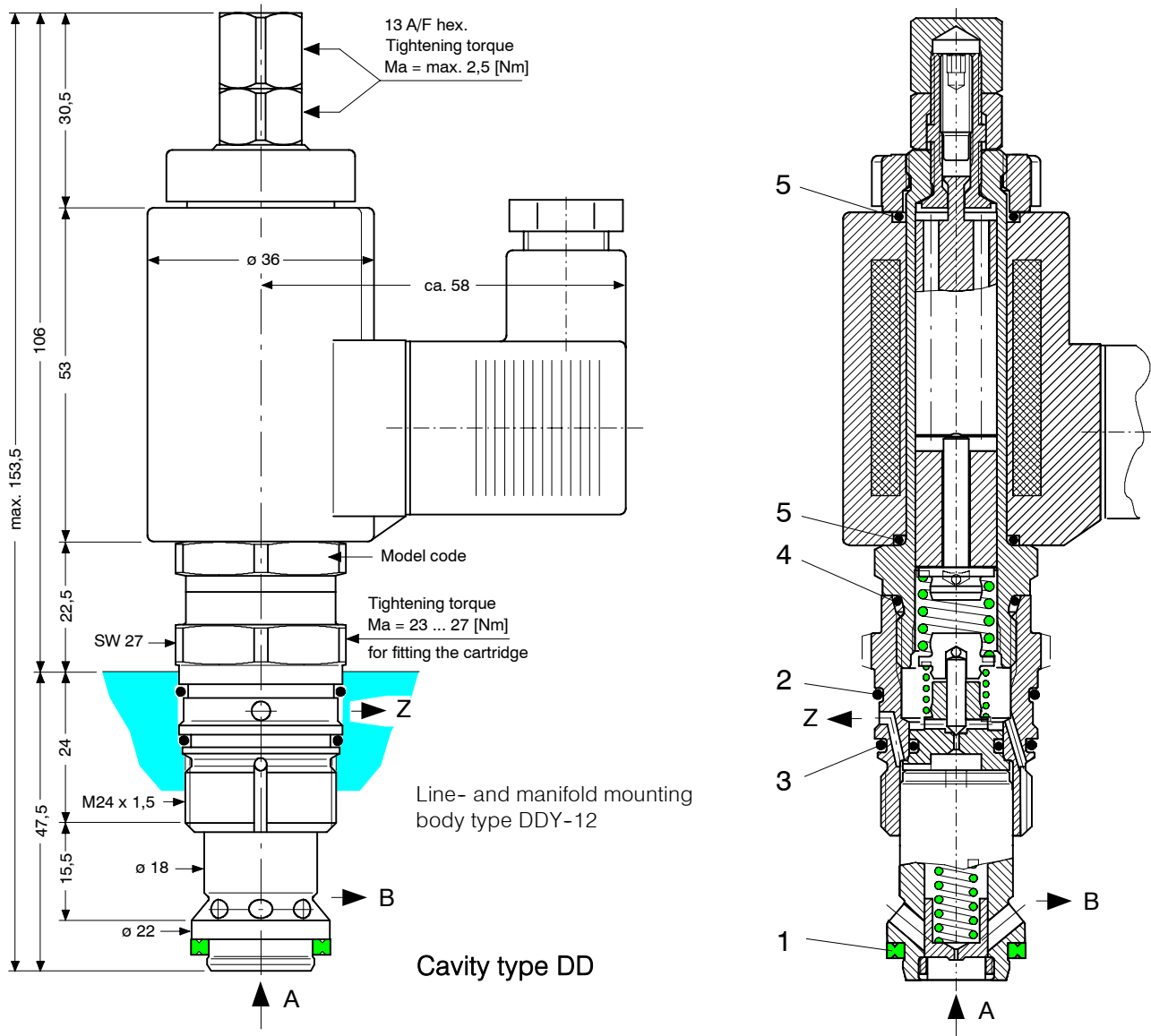

Seal kit no. DS-261, comprising:

Itm.	Qty.	Description	Size
1	1	Seal	Ø 22,00 x 16,50 x 2,50
2	1	O-ring no. 020	Ø 21,95 x 1,78 N90
3	1	O-ring	Ø 23,00 x 1,00 N90
4	1	O-ring no. 017	Ø 17,17 x 1,78 N90
5	2	O-ring	Ø 16,00 x 2,00 Viton

**8. Installation and servicing**

All work must be carried out with care and by qualified personnel only. When fitting the cartridge, ensure that the seals are oiled or greased and use the

specified tightening torque. When changing seals, oil or grease the new seals thoroughly before fitting them.

After setting the pressures, use the correct torques when tightening the lock nut and cap nut.

## 9. Ordering code

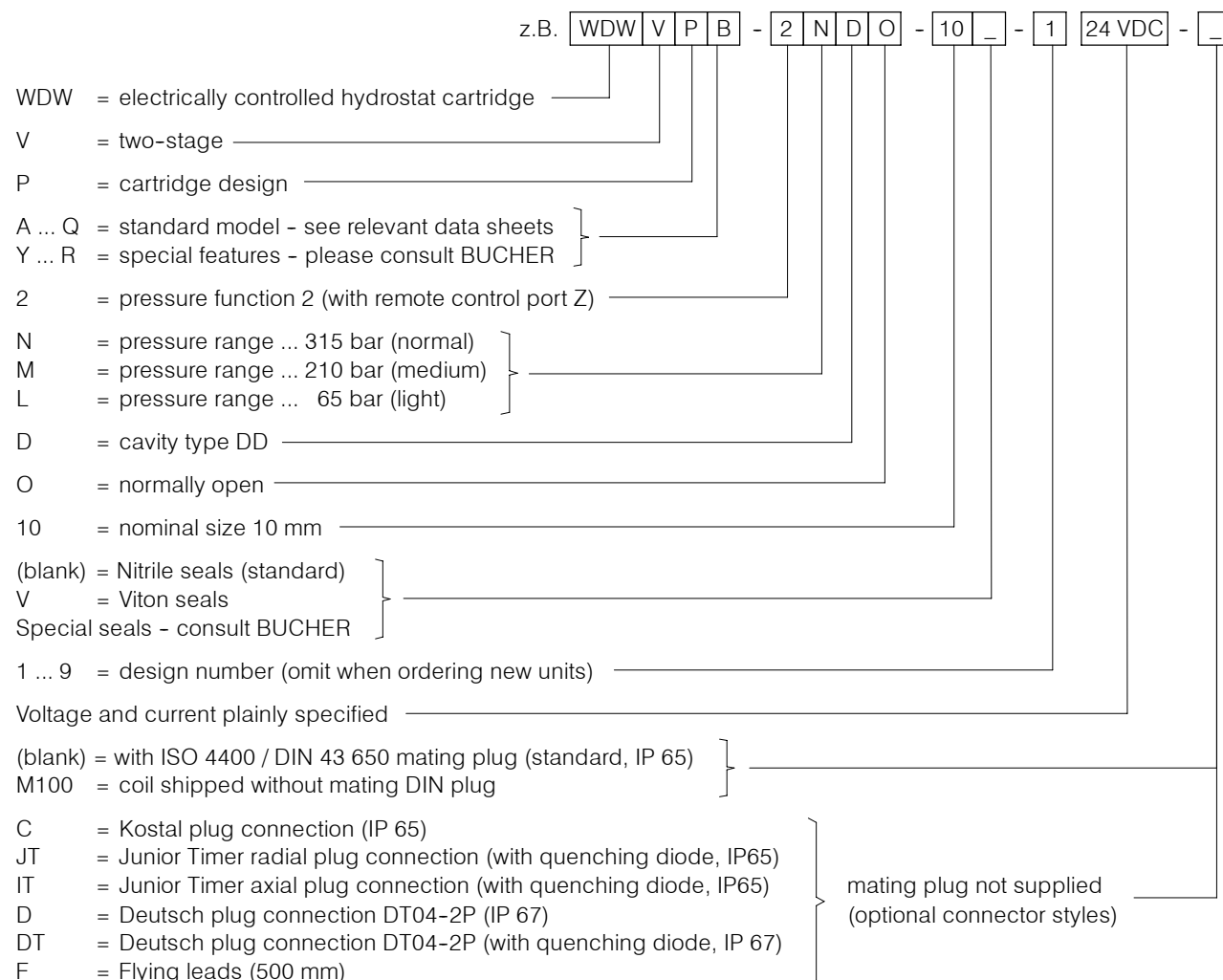

## 10. Related data sheets

Old no.	New no.	
i - 32	400-P-040011-E	The form-tool hire programme
i - 45.2	400-P-060121-E	Cavity type DD
W - 2.141	400-P-120110-E	Solenoid coils with various plug connections
G - 24.21	400-P-740111-E	Line- and manifold mounting body type DDY-12 (G 1/2")

info.ch@bucherhydraulics.com

www.bucherhydraulics.com

© 2015 by Bucher Hydraulics AG Frutigen, CH-3714 Frutigen

All rights reserved.

Data is provided for the purpose of product description only, and must not be construed as warranted characteristics in the legal sense. The information does not relieve users from the duty of conducting their own evaluations and tests. Because the products are subject to continual improvement, we reserve the right to amend the product specifications contained in this catalogue.