

## 2/2 Logic Cartridge Valve, Size 10

$Q_{\max} = 150 \text{ l/min}$ ,  $p_{\max} = 420 \text{ bar}$   
Active Control, Seated Design, Soft Switching  
Series WL22SDU..., WL22SDS1...



- Active control
- Soft switching, or soft switching + snap action
- Seated valve spool with 4 mm nose and notch
- Area ratio 2 : 1
- High flow rates with low  $\Delta p$
- Seat-valve shut-off from A  $\rightarrow$  B and B  $\rightarrow$  A
- No pilot oil consumption at Z
- With or without seal on the seated valve spool
- Various opening pressures
- With integral orifice for pilot port
- All external parts zinc plated, chromited (CrVI-free)
- Can be fitted in a line-mounting body

### 1 Description

Series WL22SDU... and WL22SDS1... actively controlled 2/2 logic valves are size 10, high performance screw-in cartridges with an M27 x 2 mounting thread. The conical-seat design ensures that the cartridges are leak-tight from A  $\rightarrow$  B and from B  $\rightarrow$  A. When the same pressure exists at ports A, B and Z, the valve spool is held in its closed position by the  $\geq 2 \text{ bar}$  compression spring. The A  $\rightarrow$  B and B  $\rightarrow$  A connection is opened or closed by relieving or pressurising the pilot port Z, bearing in mind the corresponding area- and pressure-ratios. The soft-switching feature is available in two different versions which influence the opening behaviour of the valve spool. In the case of the "U" model, the soft-switching is effective over the whole opening stroke of the valve spool, and is affected by  $\Delta p$  and Q. With the "S" (snap action) model, however, soft switching is only effective dur-

ing the beginning of the opening stroke. The switching times are by governed by the clearance between the plunger and the damping sleeve. The snap action of the "S" version results from the slot in the plunger, which causes rapid unloading of the damping chamber. In this design, the length of the overlap determines the snap start point. In addition, the spool's 4 mm nose and integral notch reinforce the soft-switching behaviour of both models. 2/2 logic cartridge valves can be used in both mobile and industrial applications. All external parts are zinc plated and chromited (CrVI-free) and are thus suitable for use in the harshest operating environments. If you intend to manufacture your own cavities or are designing a line-mounting installation, please refer to the section "Related data sheets".

### 2 Symbol

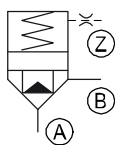

WL22SDU..., WL22SDS1...

### 3 Technical data

General characteristics	Description, value, unit
Designation	2/2 logic cartridge valve
Design	actively controlled, conical-seat type, soft switching
Mounting method	screw-in cartridge M27 x 2
Tightening torque	150 Nm $\pm$ 10 %
Size	Nominal size 10 mm, cavity type DJ

General characteristics	Description, value, unit
Weight	0.21 kg
Mounting attitude	unrestricted
Ambient temperature range	-25 °C ... +80 °C
Flow direction	A → B / B → A, see symbol

Hydraulic characteristics	Description, value, unit
Maximum operating pressure	420 bar
Maximum flow rate	150 l/min
Pressure drop	$\Delta p < 5$ bar at 100 l/min
Opening pressure - standard - optional	2.0 bar 0.4 <sup>1)</sup> / 1.0 <sup>1)</sup> / 3.0 / 6.0 / 7.5
Hydraulic fluid	HL and HLP hydraulic oils to DIN 51 524; for other fluids, please consult Bucher
Hydraulic fluid temperature range	-25 °C ... +80 °C
Viscosity range	10...650 mm <sup>2</sup> /s (cSt), recommended 15...250 mm <sup>2</sup> /s (cSt)
Minimum fluid cleanliness level Cleanliness class to ISO 4406: 1999	class 20/18/15

1) only recommended for use when the seated valve spool is not fitted with a seal.

## 4 Performance graphs

measured with oil viscosity 33 mm<sup>2</sup>/s (cSt)

$\Delta p = f(Q)$  Pressure drop - Flow rate characteristic

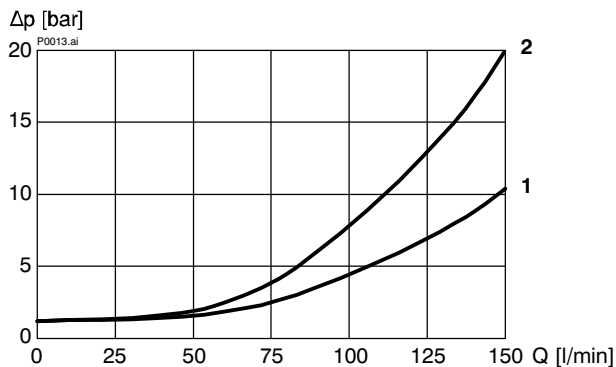

1 = cavity type DJ with annular groove  
2 = cavity type DJ without annular groove

$p = f(t)$  Soft-switching characteristic (Example)

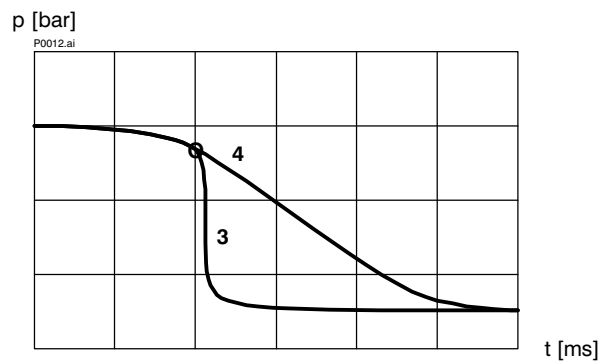

3 = soft switching, snap action  
4 = soft switching  
O = snap point



### Attention:

The  $\Delta p$  characteristic is valid when the load pressure in the A → B / B → A connection is higher than the opening pressure. If the load pressure is lower than the opening pressure, the load pressure must first rise to overcome the opening pressure before flow can occur.



### Attention:

Switching times vary with pressure, flow rate, etc. The overall soft-switching behaviour is very heavily dependent on the usage and must be established in the particular application.

## 5 Dimensions, sectional view

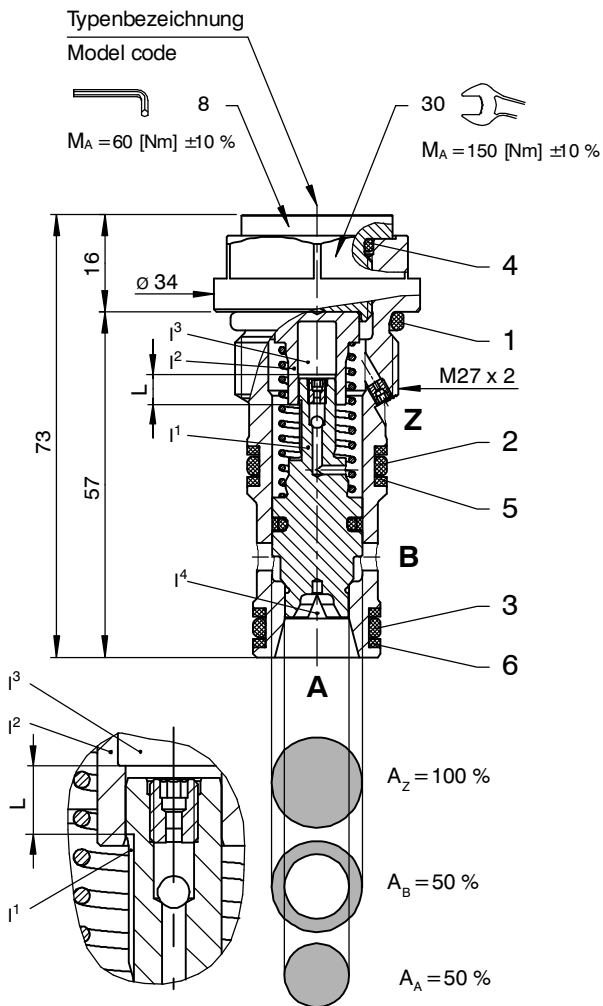

## 7 Area- and pressure-ratios

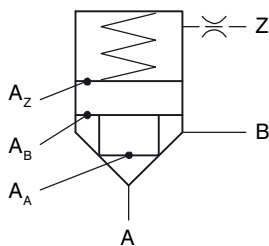

## 6 Installation information



### Important

No adjustments are necessary, since the cartridges are set in the factory.



### Attention

Only qualified personnel with mechanical skills may carry out any maintenance work. Generally, the only work that should ever be needed is to check and possibly replace the seals. When changing seals, oil or grease the new seals thoroughly before fitting them.

NBR seal kit no. DS-296-N <sup>1)</sup>

Item	Pcs.	Description
1	1	O-ring No. 119 $\varnothing 23.47 \times 2.62$ N90
2	1	O-ring No. 116 $\varnothing 18.72 \times 2.62$ N90
3	1	O-ring No. 114 $\varnothing 15.54 \times 2.62$ N90
4	1	O-ring No. 016 $\varnothing 15.60 \times 1.78$ N90
5	2	Backup ring $\varnothing 17.1 \times 2.0 \times 1.4$ FI0751
6	2	Backup ring $\varnothing 15.3 \times 2.0 \times 1.4$ FI0751



### IMPORTANT!

<sup>1)</sup> Seal kit with FKM (Viton) seals, no. DS-296-V

## 8 Adjuster types (optional)

Type "E" adjuster (WL22S.E2D...); can only be supplied with series WL22SDU... valves.



### Important

Can be used to limit the opening stroke, for example, or to block the valve spool in the closed position.

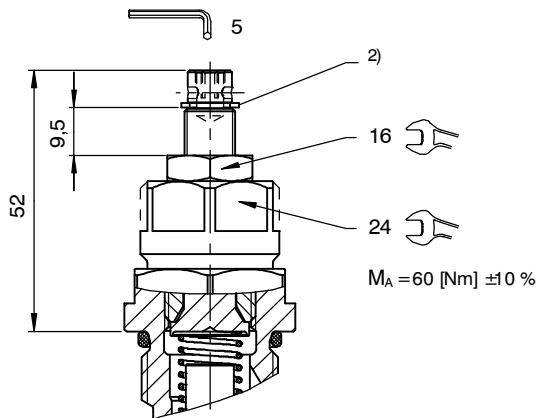

2) Snap ring (remove for "P" model)

"E" adjuster with "P" tamper-proof cap (WL22S.P2D...); can only be supplied with series WL22SDU... valves.



### Important

Valve settings can be sealed by fitting the tamper-proof cap. To fit the cap, the snap ring <sup>2)</sup> has to be removed. Subsequent adjustment is only possible by destroying the tamper-proof cap.

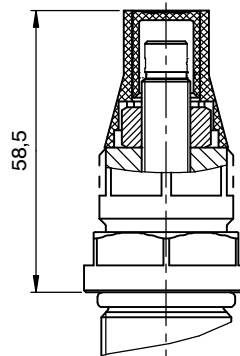

## 9 Application examples

Simplified symbol

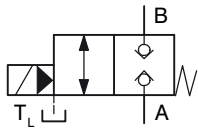

Application with seat valve, featuring soft switching when A → B / B → A opens

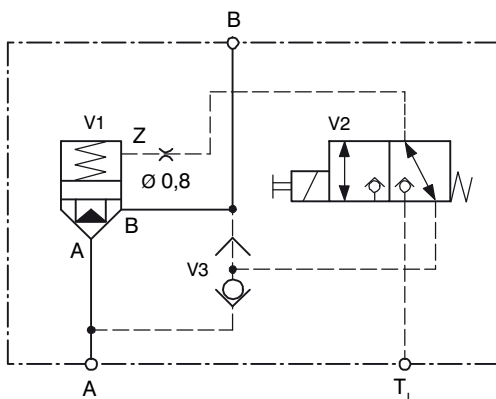

Application: accumulator charging, with soft pump switch-off to vented bypass

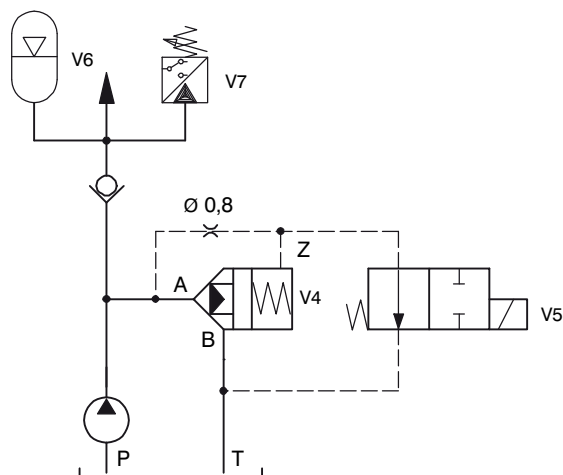

### Advantage

When the logic cartridge valve is open (flow A → B / B → A), there is no continuous flow of pilot oil to Z.

- V1 = logic cartridge valve, soft-switching
- V2 = 3/2 seat valve
- V3 = shuttle valve

- V4 = logic cartridge valve, soft-switching, or snap action
- V5 = 2/2 spool valve
- V6 = pressure accumulator
- V7 = pressure switch

## 10 Ordering code

Ex. 

WL22	SD	U	_	2	D1	3	B	-	10	_	-	_
------	----	---	---	---	----	---	---	---	----	---	---	---

WL22 = 2/2 logic cartridge valve

SD = seat valve with spool seal (standard)

S (\*) = seat valve without spool seal

U = soft switching, gentle (standard) (only with  $\geq 3,0$  bar opening pressure)

S1 = soft switching, snap action

(blank) = non-adjustable (standard)

E = adjustable (only with gentle soft-switching)

P = adjustable, adjuster is sealed (only with gentle soft switching)

2 = area ratio (main spool : seat = 2 : 1)

D1 = fixed orifice in port Z  $\varnothing$  0.8 (standard)

D2 = orifice  $\varnothing$  0.6

D3 = orifice  $\varnothing$  1.5

D4 = orifice  $\varnothing$  1.4

D5 = orifice  $\varnothing$  1.3

D6 = orifice  $\varnothing$  1.2

D7 = orifice  $\varnothing$  1.1

D8 = orifice  $\varnothing$  1.0

D9 = orifice  $\varnothing$  0.9

D0 = orifice  $\varnothing$  0.7

(blank) = no orifice

1 (\*) = opening pressure 0.4 bar

2 (\*) = opening pressure 1.0 bar

3 = opening pressure 2.0 bar (standard)

4 = opening pressure 3.0 bar

5 = opening pressure 6.0 bar

6 = opening pressure 7.5 bar

B ... Q = standard model - see relevant data sheets

Z ... R = special features - please consult Bucher

10 = nominal size 10 mm

(blank) = Nitrile seals (standard)

V = Viton seals  
(special seals - please consult Bucher)

1 ... 9 = design number (omit when ordering new units)

} optional orifice in port Z (type G / M3)

(\*) In applications with an opening pressure of less than 2 bar, valve types WL22SU2... or WL22SS12... must be used.  
I.e. the seal on the spool is omitted, and the valve is not leak-tight from A  $\rightarrow$  B.

## 11 Related data sheets

Reference no.	(Old no.)	Description
400-P-040011	(i-32)	The form-tool hire programme
400-P-060181	(i-45.11)	Cavity type DJ
400-P-740131	(G-24.31)	Line-mounting body, type GADJA (G 3/4")

info.ch@bucherhydraulics.com

www.bucherhydraulics.com

© 2015 by Bucher Hydraulics AG Frutigen, CH-3714 Frutigen

All rights reserved.

Data is provided for the purpose of product description only, and must not be construed as warranted characteristics in the legal sense. The information does not relieve users from the duty of conducting their own evaluations and tests. Because the products are subject to continual improvement, we reserve the right to amend the product specifications contained in this catalogue.

Classification: 430.300.-.305.320.335