

W-118

Flow controlled 4/2 self-reversing valve, size 3

Series WOFA ...

30 l/min, 210 bar

- with ISO 4401 / CETOP R35H size 3, NFPA D03, DIN 24 340 A6 interface
- automatic, load-independent reversal
- predefined actuator direction at start-up
- no reversal pressures to set
- simple construction (only 1 moving part)
- long service life



SYMBOL

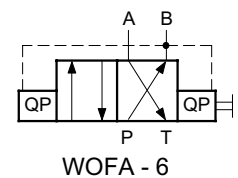

DESCRIPTION

The valve produces automatic reciprocation when connected, for example, to a hydraulic cylinder.

When the cylinder reaches the end of its stroke, or when the load pressure rises to the relief valve setting, there is no longer any flow through the valve. The cessation of flow causes the valve spool to shuttle to its other end position, and consequently the actuator moves in the reverse direction. The reversal process is virtually independent of the load pressure.

The process continues as long as the specified minimum flows and pressures are produced by the pump.

In order to set the system pressure limiter, it will be evident that the self-reversing function of this valve must be blocked: See SETTING SYSTEM RELIEF VALVE.

The valve is designed in such a way that when pressure is connected to the P port the first flow condition is always $P \Rightarrow B$ and $A \Rightarrow T$. This means, for example, that where an unequal area cylinder is used on a machine with strict safety requirements, then the A port of the valve should be connected to the full bore end of the cylinder and the B port to the annulus end (e.g. compactor circuits, where the first cylinder movement must be to retract).

DIMENSIONS

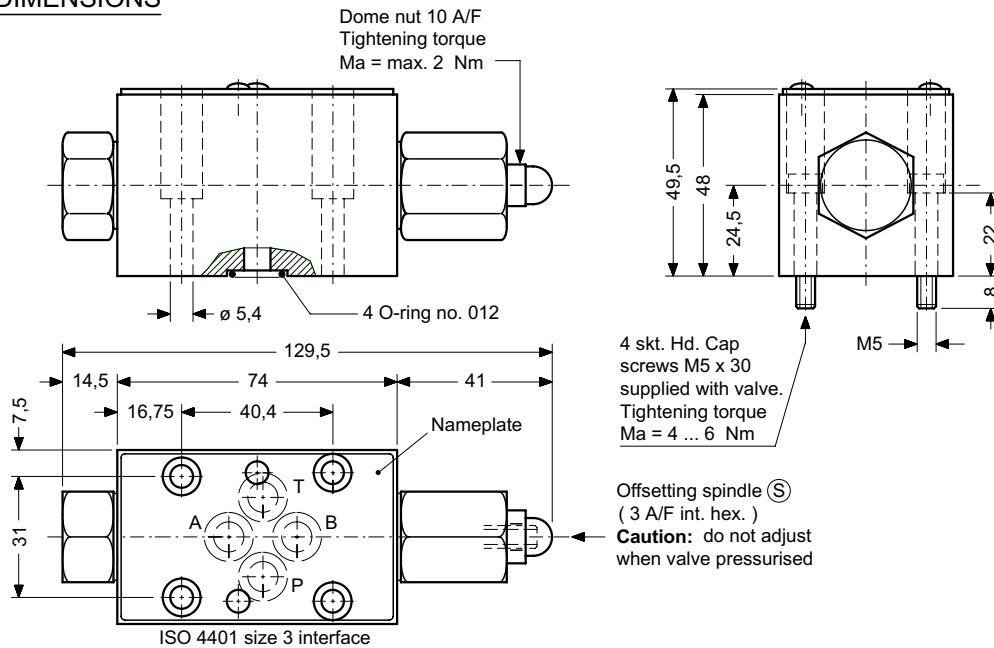

SYMBOL

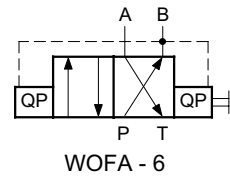

SETTING SYSTEM RELIEF VALVE

1. Switch off pump, alternatively reduce pressure to minimum (10 bar max.).
2. To set the system relief valve, first block the automatic reversal of the WOFA-6. Remove the dome nut, turn the offsetting spindle Ⓢ clockwise until it hits its inner end stop. The spool is now clamped $P \Rightarrow B, A \Rightarrow T$.
3. Start the pump. Set the required relief pressure.
4. Stop the pump
5. Turn the offsetting spindle Ⓢ anticlockwise until it hits its outer end stop, then replace the dome nut.

CAUTION: Never turn the offsetting spindle Ⓢ when the valve is pressurised, as this can cause seal damage. If necessary, switch off the pump.

SAFETY NOTE

When the pump is switched off (e.g. emergency switch in the plant), the valve spool will reset to $P \Rightarrow B, A \Rightarrow T$ (the "Pump Start" position) after 0,5 secs (measured with fluid viscosity 33 cSt). The cylinder, connected as shown in the APPLICATION EXAMPLE, is ready to retract.

Deviation from the circuitry shown in the application example, and changes in the fluid viscosity can result in an increase in the minimum required reversal time.

APPLICATION EXAMPLE

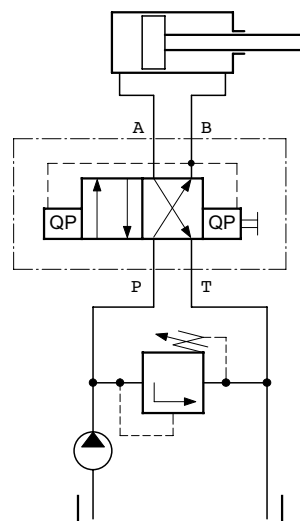

SCHEMATIC SECTION

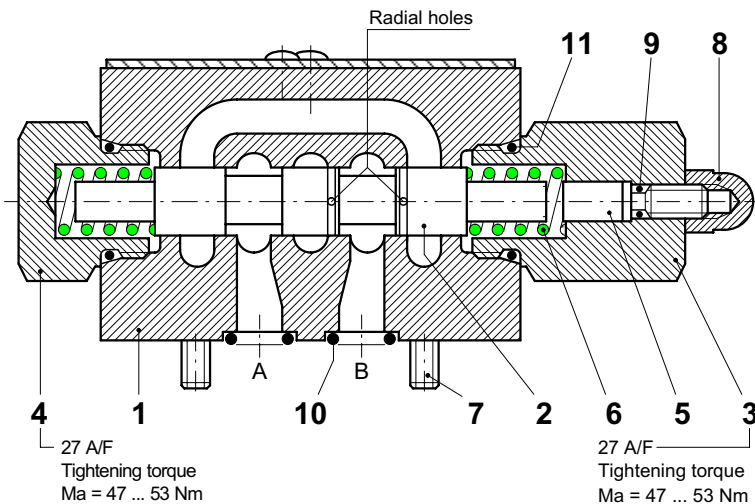

COMPONENTS / SERVICE PARTS

lt.	Qty.	Description	
			1*) Part of seal kit no. DS-231 ▲ available as service part
1	1	Valve body	48 x 46 x 74
2	1	Self-reversing spool assy.	∅ 12 x 84
3	1	Spring cap	24 A/F x 37,5
4	1	Plug	24 A/F x 23
5	1	Offsetting spindle	∅ 7 x 25
6	2	Spring	1,4 x 11,2 x 20 iG = 8,5
7	4	Hex.skt.hd.cap screw M5 x 30 St 8.8	DIN 912
8	1	Dome nut	M6 PA 6.6 DIN 1587
	1	Seal kit no. DS-231, comprising *):	
9	1*)	O-ring no. 007	∅ 3,68 x 1,78 N90
10	4*)	O-ring no. 012	∅ 9,25 x 1,78 N90
11	2*)	O-ring no. 114	∅ 15,54 x 2,62 N90

TO ORDER SERVICE PARTS, STATE:

- complete unit model code from the nameplate, including the design number
- data sheet number, including issue data
- part item number from above list
- part description from above list
- quantity required

INSTALLATION AND SERVICING

MUST BE CARRIED OUT WITH CARE AND BY QUALIFIED PERSONNEL ONLY.

When servicing the valve (cleaning, seal change etc.) note the following:

1. Unscrew and remove dome nut item 8, spring cap 3 and plug 4.
2. Remove the 2 springs item 6.
3. Carefully slide out the self-reversing spool item 2.
4. The self-reversing spool item 2 is asymmetric and must not be reinserted the wrong way round, otherwise the normal Pump Start function $P \Rightarrow B$ and $A \Rightarrow T$ will be reversed to $P \Rightarrow A$ and $B \Rightarrow T$.

The correct spool orientation can be identified by the 2 small radial holes. The spool is factory-inserted so that these 2 holes are above the B port of the hydraulic interface.

5. When fitting new seals ensure that they are first well oiled or greased.
6. Before refitting the spring cap item 3, the offsetting spindle item 5 must be fully retracted into the spring cap allow the spool to oscillate freely.
7. Observe the correct tightening torques for spring cap item 3, plug 4 and plastic dome nut 8.

MAIN CHARACTERISTICS

Type	4/2, self-reversing
Design	spool
Mounting method	manifold mounting
Size	ISO 4401 size 03 interface
Mass	1,10 kg
Mounting attitude	unrestricted
Flow direction	see symbol
Operating pressure	50 ... 210 bar higher pressures - contact HTF
Fluids	hydraulic oils HL and HLP to DIN 51 524 other fluids - contact HTF

Min. fluid cleanliness	18/14 to ISO 4406 / CETOP RP70H 8 ... 9 to NAS 1638
Fluid temp. range	-20° ... +60° C
Viscosity range	20 ... 200 cSt
Flow range	Q $P \Rightarrow A$ / $A \Rightarrow T$ = max. 60 l/min Q $P \Rightarrow B$ / $B \Rightarrow T$ = min. 3 l/min Q $P \Rightarrow B$ / $B \Rightarrow T$ = max. 30 l/min
Cylinder area ratio (see perf. curves)	recommended $\phi = 1 \dots 1,5$ permitted $\phi = 1 \dots 2$
Cylinder internal leakage at $p = 210$ bar	max. permissible 0,5 l/min

APPLICATIONS

- e.g.
- compactor controls
 - in-container compactors
 - slurry scrapers
 - piston-type intensifiers

PERFORMANCE DATA

Oil viscosity 33 cSt

$$\phi = \frac{\text{Cylinder full bore area}}{\text{Full bore area} - \text{Piston rod area}}$$

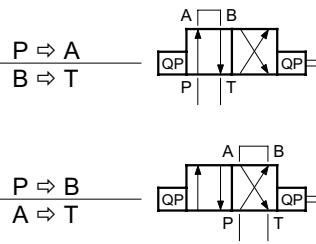
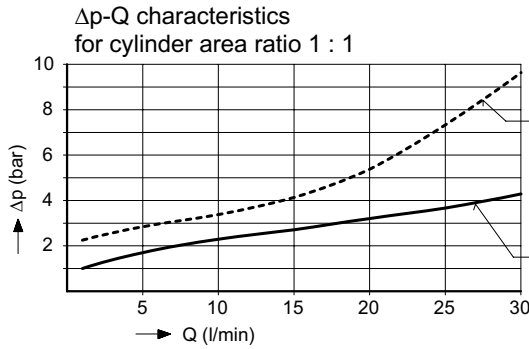

Cylinder $\phi = 1 : 1$

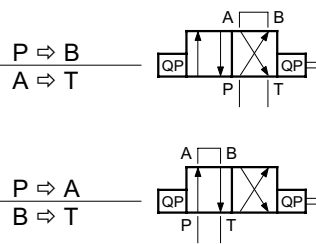
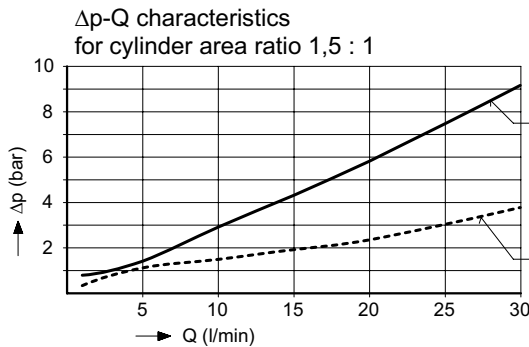
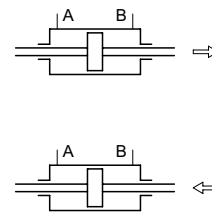

Cylinder $\phi = 1,5 : 1$

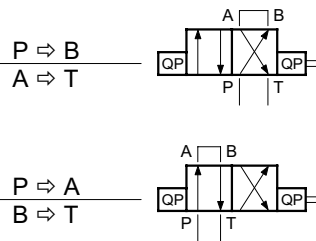
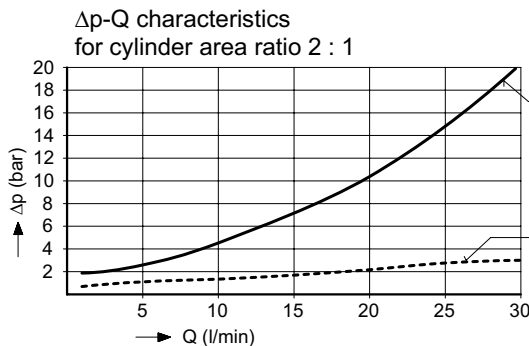
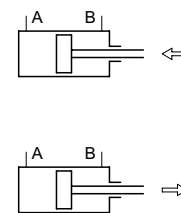

Cylinder $\phi = 2 : 1$

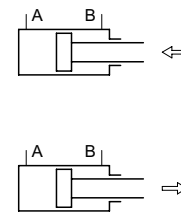

MODEL CODE KEY

4/2 self-reversing valve

A ... Q = **standard** model per current data sheet
Z ... R = special features by arrangement

6 = ISO 4401 size 3 interface

Blank = Nitrile seals (**standard**)

V = Viton seals

for special seals - contact HTF

1 ... 9 = design no. (omit when ordering)

Ex. WOF A - 6 - - 1